



Operation and Maintenance Manual

C1.7 and C2.2 Industrial Engines

J7J 1-UP (Engine)
TM8 1-UP (Engine)
J27 1-UP (Engine)



Scan to find and purchase genuine Cat® parts and related service information.



Important Safety Information

Most accidents that involve product operation, maintenance and repair are caused by failure to observe basic safety rules or precautions. An accident can often be avoided by recognizing potentially hazardous situations before an accident occurs. A person must be alert to potential hazards, including human factors that can affect safety. This person should also have the necessary training, skills and tools to perform these functions properly.

Improper operation, lubrication, maintenance or repair of this product can be dangerous and could result in injury or death.

Do not operate or perform any lubrication, maintenance or repair on this product, until you verify that you are authorized to perform this work, and have read and understood the operation, lubrication, maintenance and repair information.

Safety precautions and warnings are provided in this manual and on the product. If these hazard warnings are not heeded, bodily injury or death could occur to you or to other persons.

The hazards are identified by the "Safety Alert Symbol" and followed by a "Signal Word" such as "DANGER", "WARNING" or "CAUTION". The Safety Alert "WARNING" label is shown below.



The meaning of this safety alert symbol is as follows:

Attention! Become Alert! Your Safety is Involved.

The message that appears under the warning explains the hazard and can be either written or pictorially presented.

A non-exhaustive list of operations that may cause product damage are identified by "NOTICE" labels on the product and in this publication.

Caterpillar cannot anticipate every possible circumstance that might involve a potential hazard. The warnings in this publication and on the product are, therefore, not all inclusive. You must not use this product in any manner different from that considered by this manual without first satisfying yourself that you have considered all safety rules and precautions applicable to the operation of the product in the location of use, including site-specific rules and precautions applicable to the worksite. If a tool, procedure, work method or operating technique that is not specifically recommended by Caterpillar is used, you must satisfy yourself that it is safe for you and for others. You should also ensure that you are authorized to perform this work, and that the product will not be damaged or become unsafe by the operation, lubrication, maintenance or repair procedures that you intend to use.

The information, specifications, and illustrations in this publication are on the basis of information that was available at the time that the publication was written. The specifications, torques, pressures, measurements, adjustments, illustrations, and other items can change at any time. These changes can affect the service that is given to the product. Obtain the complete and most current information before you start any job. Cat dealers have the most current information available.

NOTICE

When replacement parts are required for this product Caterpillar recommends using original Caterpillar® replacement parts.

Other parts may not meet certain original equipment specifications.

When replacement parts are installed, the machine owner/user should ensure that the machine remains in compliance with all applicable requirements.

In the United States, the maintenance, replacement, or repair of the emission control devices and systems may be performed by any repair establishment or individual of the owner's choosing.

Table of Contents

Foreword	4	Cold Weather Operation	62
Safety Section		Maintenance Section	
Safety Messages	6	Refill Capacities.....	66
General Hazard Information.....	13	Maintenance Recommendations	72
Burn Prevention.....	17	Maintenance Interval Schedule.....	75
Fire Prevention and Explosion Prevention.....	18	Warranty Section	
Crushing Prevention and Cutting Prevention..	20	Warranty Information.....	126
Mounting and Dismounting	21	Reference Information Section	
High Pressure Fuel Lines	21	Engine Ratings	127
Before Starting Engine	23	Customer Service.....	129
Engine Starting.....	24	Reference Materials	130
Engine Stopping	24	Index Section	
Electrical System.....	24	Index.....	132
Engine Electronics.....	25		
Product Information Section			
Model Views	27		
Product Identification Information	41		
Operation Section			
Lifting and Storage	42		
Gauges and Indicators	45		
Features and Controls.....	46		
Engine Diagnostics	51		
Engine Starting.....	53		
Engine Operation	57		
Engine Stopping	60		

Foreword

California Proposition 65 Warning

Diesel engine exhaust and some of its constituents are known to the State of California to cause cancer, birth defects, and other reproductive harm.



WARNING – This product can expose you to chemicals including ethylene glycol, which is known to the State of California to cause birth defects or other reproductive harm. For more information go to:

www.P65Warnings.ca.gov

Do not ingest this chemical. Wash hands after handling to avoid incidental ingestion.



WARNING – This product can expose you to chemicals including lead and lead compounds, which are known to the State of California to cause cancer, birth defects, or other reproductive harm. For more information go to:

www.P65Warnings.ca.gov

Wash hands after handling components that may contain lead.

Literature Information

This manual contains safety, operation instructions, lubrication, and maintenance information. This manual should be stored in or near the engine area in a literature holder or literature storage area. Read, study, and keep it with the literature and engine information.

English is the primary language for all Cat publications. The English used facilitates translation and consistency in electronic media delivery.

Some photographs or illustrations in this manual show details or attachments that may be different from your engine. Guards and covers may have been removed for illustrative purposes. Continuing improvement and advancement of product design may have caused changes to your engine which are not included in this manual. Whenever a question arises regarding your engine, or this manual, please consult with your Cat dealer for the latest available information.

Safety

This safety section lists basic safety precautions. In addition, this section identifies hazardous, warning situations. Read and understand the basic precautions listed in the safety section before operating or performing lubrication, maintenance, and repair on this product.

Operation

Operating techniques outlined in this manual are basic. They assist with developing the skills and techniques required to operate the engine more efficiently and economically. Skill and techniques develop as the operator gains knowledge of the engine and its capabilities.

The operation section is a reference for operators. Photographs and illustrations guide the operator through procedures of inspecting, starting, operating, and stopping the engine. This section also includes a discussion of electronic diagnostic information.

Maintenance

The maintenance section is a guide to engine care. The illustrated, step-by-step instructions are grouped by fuel consumption, service hours and/or calendar time maintenance intervals. Items in the maintenance schedule are referenced to detailed instructions that follow.

Use fuel consumption or service hours to determine intervals. Calendar intervals shown (daily, annually, etc.) may be used instead of service meter intervals if they provide more convenient schedules and approximate the indicated service meter reading.

Recommended service should be performed at the appropriate intervals as indicated in the Maintenance Interval Schedule. The actual operating environment of the engine also governs the Maintenance Interval Schedule. Therefore, under severe, dusty, wet, or freezing cold operating conditions, more frequent lubrication, and maintenance than is specified in the Maintenance Interval Schedule may be necessary.

The maintenance schedule items are organized for a preventive maintenance management program. If the preventive maintenance program is followed, a periodic tune-up is not required. The implementation of a preventive maintenance management program should minimize operating costs through cost avoidances resulting from reductions in unscheduled downtime and failures.

Maintenance Intervals

Perform maintenance on items at multiples of the original requirement. Each level and/or individual items in each level should be shifted ahead or back depending upon your specific maintenance practices, operation, and application. We recommend that the maintenance schedules be reproduced and displayed near the engine as a convenient reminder. We also recommend that a maintenance record be maintained as part of the engine's permanent record.

See the section in the Operation and Maintenance Manual, "Maintenance Records" for information regarding documents that are accepted as proof of maintenance or repair. Your authorized Cat dealer can assist you in adjusting your maintenance schedule to meet the needs of your operating environment.

Overhaul

Major engine overhaul details are not covered in the Operation and Maintenance Manual except for the interval and the maintenance items in that interval. Major repairs are best left to trained personnel or an authorized Cat dealer. Your Cat dealer offers various options regarding overhaul programs. If you experience a major engine failure, there are also numerous after failure overhaul options available from your Cat dealer. Consult with your dealer for information regarding these options.

Safety Section

i09669672

Safety Messages

SMCS Code: 1000; 7405

There may be several specific warning signs on your engine. The exact location and a description of the warning signs are reviewed in this section. Become familiar with all warning signs.

Ensure that all the warning signs are legible. Clean the warning signs or replace the warning signs if the words cannot be read or if the illustrations are not visible. Use a cloth, water, and soap to clean the warning signs. Do not use solvents, gasoline, or other harsh chemicals. Solvents, gasoline, or harsh chemicals could loosen the adhesive that secures the warning signs. The warning signs that are loosened could drop off the engine.

Replace any warning sign that is damaged or missing. If a warning sign is attached to a part of the engine that is replaced, install a new warning sign on the replacement part. Your Caterpillar dealer can provide new warning signs.

(1) Universal Warning



Do not operate or work on this equipment unless you have read and understand the instructions and warnings in the Operation and Maintenance Manuals. Failure to follow the instructions or heed the warnings could result in serious injury or death.

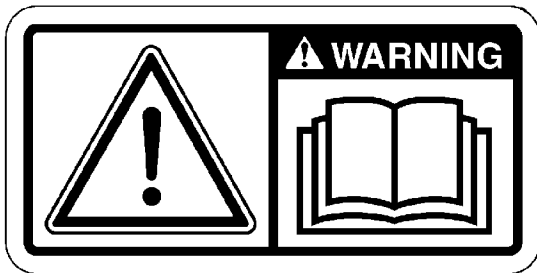

Illustration 1

g01154807

Typical example

The Universal Warning label (1) is on the side of the valve mechanism cover. Refer to illustration 2 .

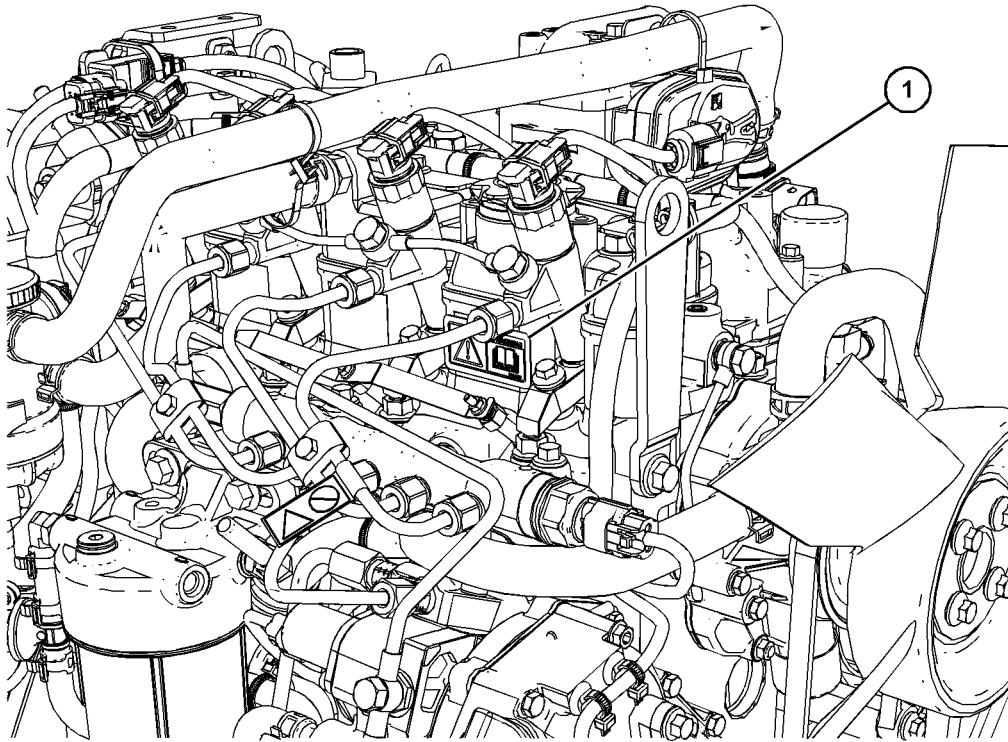

Illustration 2
Typical example

g06310205

(2) Hand (High Pressure)

⚠ WARNING

Contact with high pressure fuel may cause fluid penetration and burn hazards. High pressure fuel spray may cause a fire hazard. Failure to follow these inspection, maintenance and service instructions may cause personal injury or death.

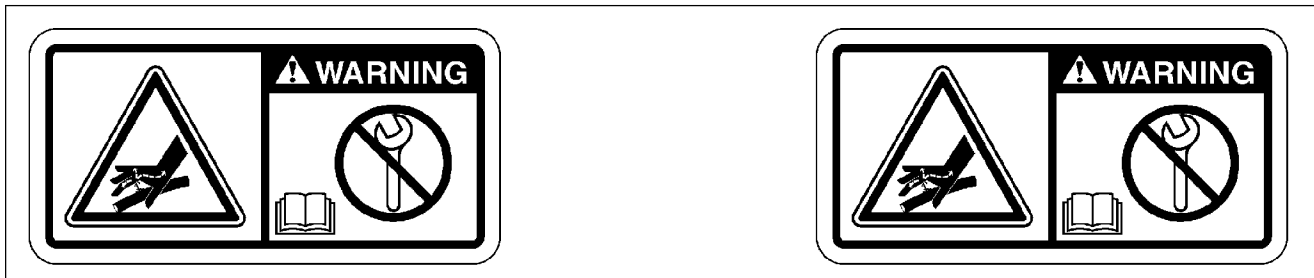

Illustration 3
Typical example

g02382677

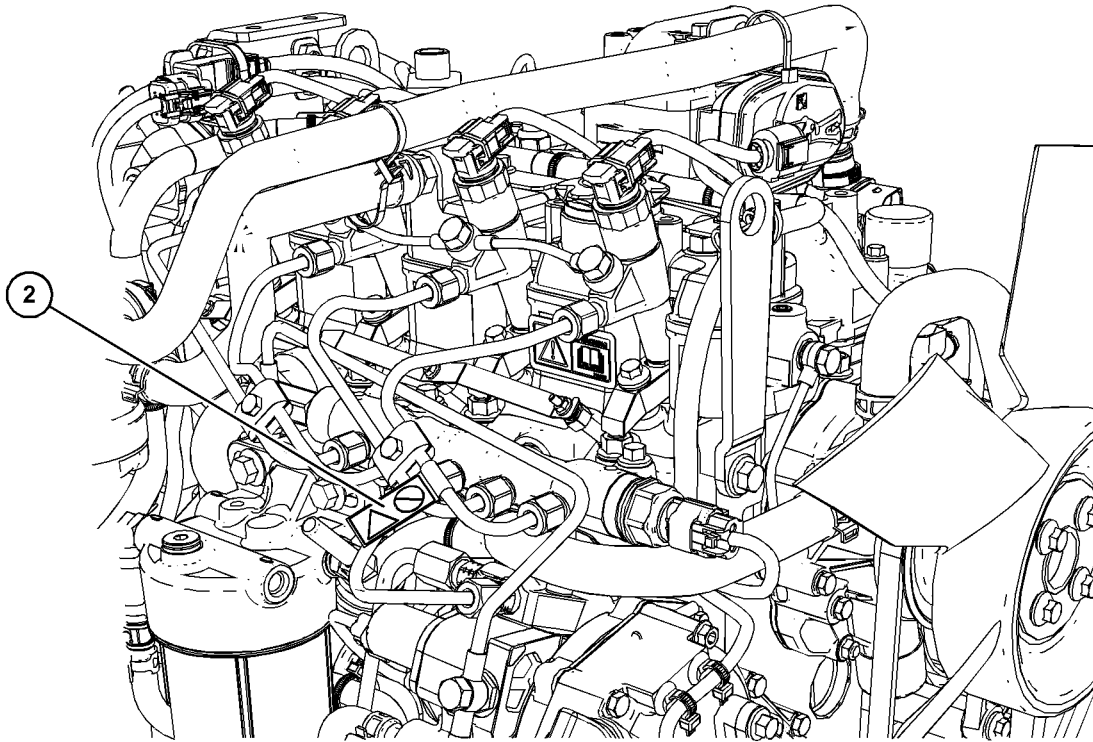

Illustration 4

g06310206

Typical example

The warning label for the Hand (High Pressure) (2) is a wrap around label that is installed on the high-pressure fuel line.

(3) Ether Warning

An ether warning label should be installed on the air cleaner or close to the air cleaner. The location will depend on the application.

⚠ WARNING

Do not operate or work on this equipment unless you have read and understand the instructions and warnings in the Operation and Maintenance Manuals. Failure to follow the instructions or heed the warnings could result in serious injury or death.



Illustration 5

g01154809

Open Power Unit (OPU)

4 Cylinder OPU

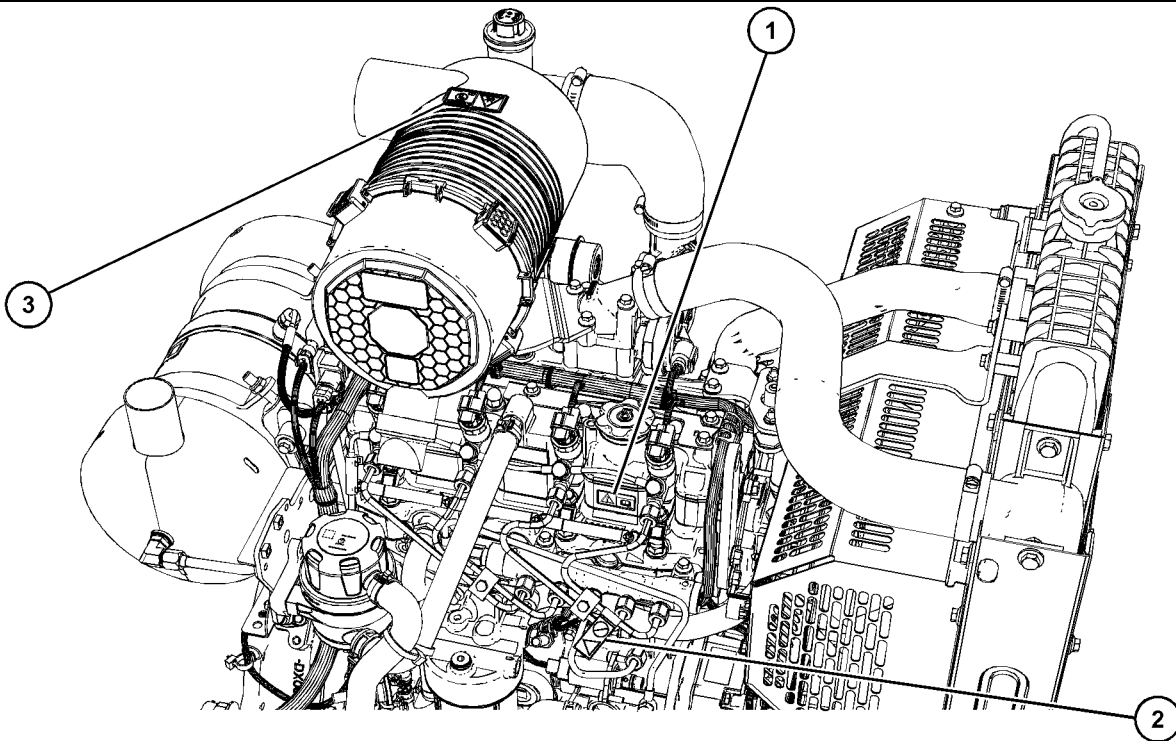

Illustration 6
Typical example

g07520353

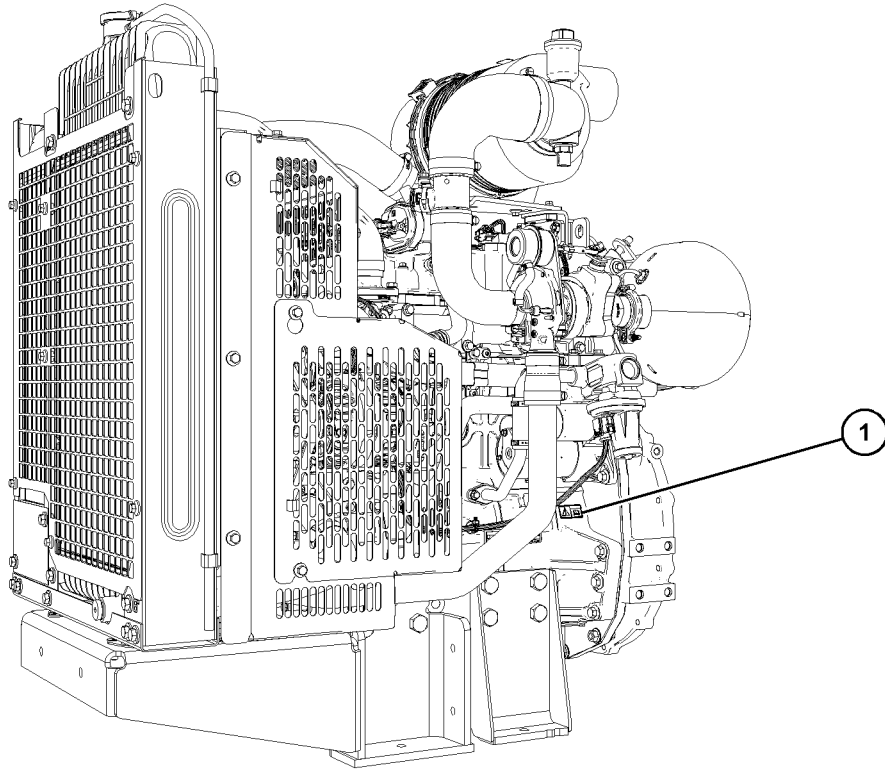

Illustration 7

g07520365

Typical example

(1) Universal Warning



Do not operate or work on this equipment unless you have read and understand the instructions and warnings in the Operation and Maintenance Manuals. Failure to follow the instructions or heed the warnings could result in serious injury or death.

(2) Hand (High Pressure)



Contact with high pressure fuel may cause fluid penetration and burn hazards. High pressure fuel spray may cause a fire hazard. Failure to follow these inspection, maintenance and service instructions may cause personal injury or death.

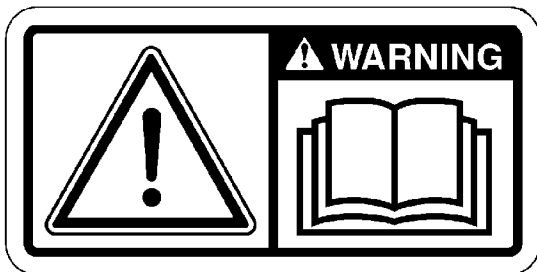

Illustration 8

g01154807

Typical example



Illustration 9

g02382677

Typical example

(3) Ether Warning

⚠ WARNING

Do not operate or work on this equipment unless you have read and understand the instructions and warnings in the Operation and Maintenance Manuals. Failure to follow the instructions or heed the warnings could result in serious injury or death.



Illustration 10

g01154809

3 Cylinder OPU

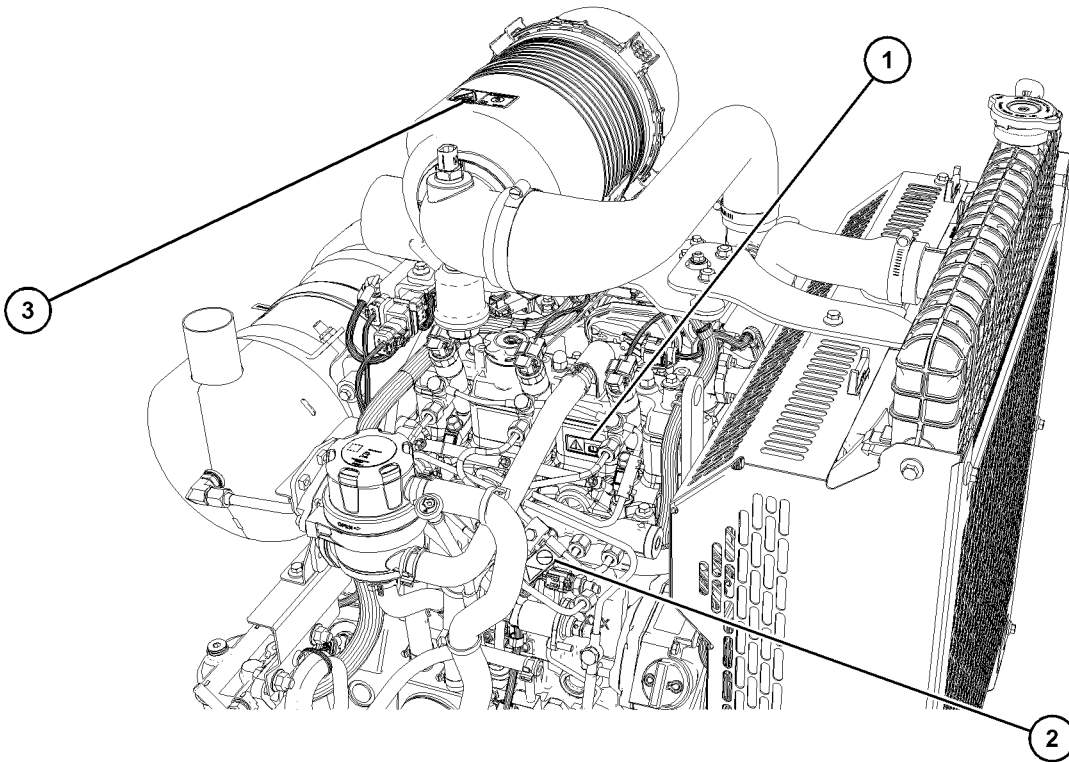

Illustration 11
Typical example

g07520376

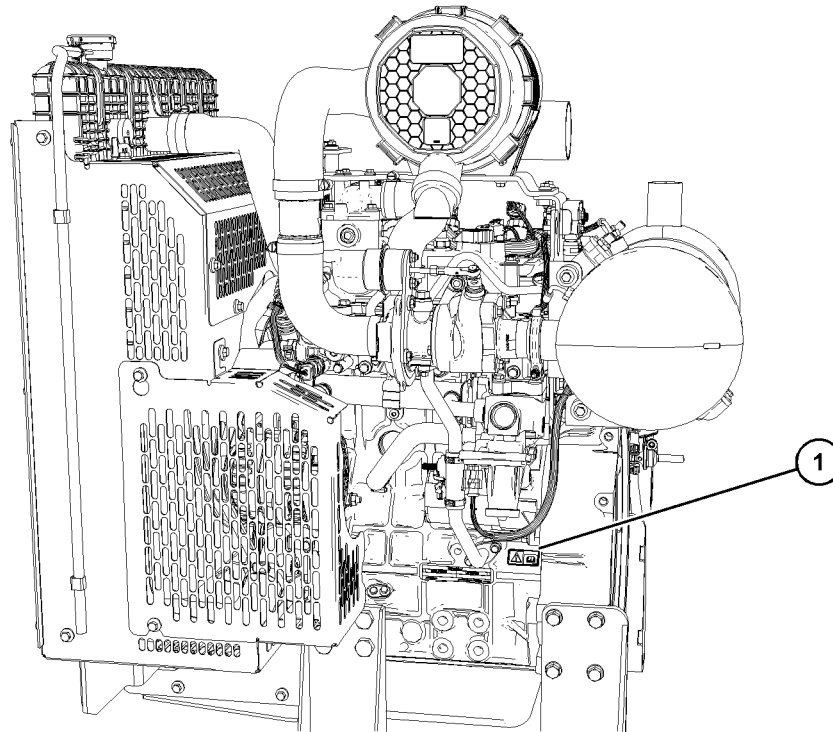

Illustration 12

g07520392

Typical example

i08312249

General Hazard Information

SMCS Code: 1000; 7405

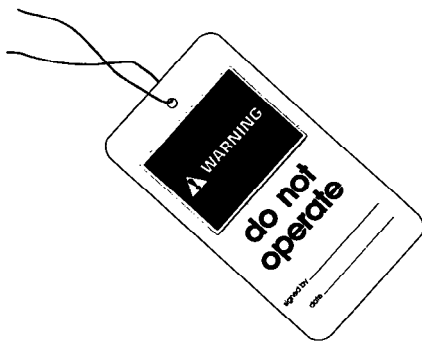

Illustration 13

g00104545

Attach a “Do Not Operate” warning tag or a similar warning tag to the start switch or to the controls before the engine is serviced or before the engine is repaired. Attach the warning tags to the engine and to each operator control station. When appropriate, disconnect the starting controls.

Do not allow unauthorized personnel on the engine, or around the engine when the engine is being serviced.

- Tampering with the engine installation or tampering with the OEM supplied wiring can be dangerous. Personal injury, death and/or engine damage could result.
- Vent the engine exhaust to the outside when the engine is operated in an enclosed area.
- If the engine is not running, do not release the secondary brake or the parking brake systems unless the vehicle is blocked or unless the vehicle is restrained.

Unless other instructions are provided, perform the maintenance under the following conditions:

- The key switch is in the OFF position.
- The engine is stopped. Ensure that the engine cannot be started.
- The protective locks or the controls are in the applied position.
- Engage the secondary brakes or parking brakes.

Safety Section

General Hazard Information

- Block the vehicle or restrain the vehicle before maintenance or repairs are performed.
- After the ECM has powered down, disconnect the batteries when maintenance is performed or when the electrical system is serviced. Disconnect the battery ground leads. Use electrical insulating tape on the leads to help prevent sparks.
- If equipped, disconnect the connectors for the unit injectors that are located on the valve cover base. This action will help prevent personal injury from the high voltage to the unit injectors. Do not come in contact with the unit injector terminals while the engine is operating.
- Do not attempt any repairs or any adjustments to the engine while the engine is operating.
- Do not attempt any repairs that are not understood. Use the proper tools. Replace any equipment that is damaged or repair the equipment.
- For initial start-up of a new engine or for starting an engine that has been serviced, make provisions to stop the engine if an overspeed occurs. The stopping of the engine may be accomplished by shutting off the fuel supply and/or the air supply to the engine. Ensure that only the fuel supply line is shut off. Ensure that the fuel return line is open.
- Start the engine from the operators station (cab). Never short across the starting motor terminals or the batteries. This action could bypass the engine neutral start system and/or the electrical system could be damaged.

Engine exhaust contains products of combustion which may be harmful to your health. Always start the engine and operate the engine in a well ventilated area. If the engine is in an enclosed area, vent the engine exhaust to the outside.

To help prevent spraying or splashing of pressurized fluids, hold a rag over the part that is being removed.

Remove the following parts with caution.

- Filler caps
- Grease fittings
- Pressure taps
- Breathers
- Drain plugs

Use caution when cover plates are removed. Gradually loosen, but do not remove the last two bolts or nuts that are located at opposite ends of the cover plate or the device. Before removing the last two bolts or nuts, pry the cover loose to relieve any spring pressure or other pressure.

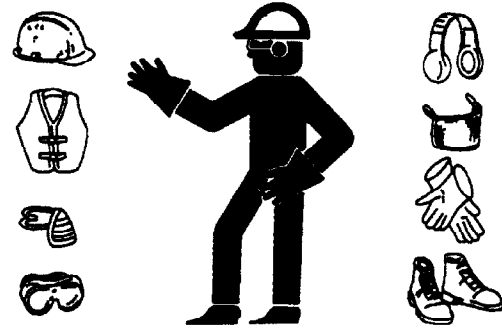

Illustration 14

g00702020

- Do not stand on the engine.
- Wear a hard hat, protective glasses, and other protective equipment, as required.
- Caterpillar recommend that you do not stand next to an exposed running engine unless it is necessary when carrying out daily checks or maintenance procedures. The appropriate Personal Protective Equipment (PPE) must be worn when standing next to an exposed running engine.
- Do not wear loose clothing or jewelry that can snag on controls or on other parts of the engine.
- Ensure that all protective guards and all covers are secured in place on the engine.
- Never put maintenance fluids into glass containers. Glass containers can break.
- Use all cleaning solutions with care.
- Report all necessary repairs.

Pressurized Air and Water

Pressurized air and/or water can cause debris and/or hot water to be blown out. This action could result in personal injury.

When pressurized air and/or pressurized water is used for cleaning, wear protective clothing, protective shoes, and eye protection. Eye protection includes goggles or a protective face shield.

The maximum air pressure for cleaning purposes must be below 205 kPa (30 psi). The maximum water pressure for cleaning purposes must be below 275 kPa (40 psi).

Fluid Penetration

Pressure can be trapped in the hydraulic circuit long after the engine has been stopped. The pressure can cause hydraulic fluid or items such as pipe plugs to escape rapidly if the pressure is not relieved correctly.

Do not remove any hydraulic components or parts until pressure has been relieved or personal injury may occur. Do not disassemble any hydraulic components or parts until pressure has been relieved or personal injury may occur. Refer to the OEM information for any procedures that are required to relieve the hydraulic pressure.

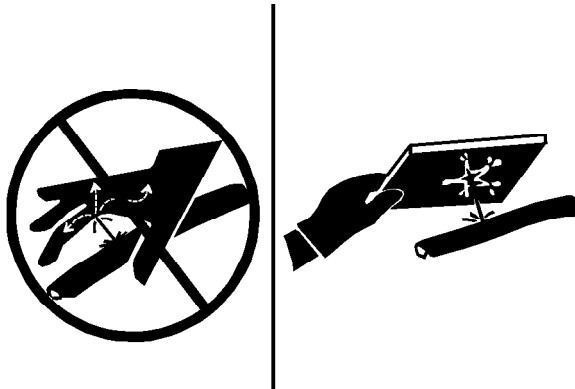

Illustration 15

g00687600

Always use a board or cardboard when you check for a leak. Leaking fluid that is under pressure can penetrate body tissue. Fluid penetration can cause serious injury and possible death. A pin hole leak can cause severe injury. If fluid is injected into your skin, you must get treatment immediately. Seek treatment from a doctor that is familiar with this type of injury.

Containing Fluid Spillage

Care must be taken to ensure that fluids are contained during performance of inspection, maintenance, testing, adjusting, and repair of the product. Be prepared to collect the fluid with suitable containers before opening any compartment or disassembling any component containing fluids.

Dispose of all fluids according to local regulations and mandates.

Static Electricity Hazard when Fueling with Ultra-low Sulfur Diesel Fuel

The removal of sulfur and other compounds in ultra-low sulfur diesel fuel (ULSD fuel) decreases the conductivity of ULSD and increases the ability of ULSD to store static charge. Refineries may have treated the fuel with a static dissipating additive. Many factors can reduce the effectiveness of the additive over time. Static charges can build up in ULSD fuel while the fuel is flowing through fuel delivery systems. Static electricity discharge when combustible vapors are present could result in a fire or explosion. Ensure that the entire system used to refuel your machine (fuel supply tank, transfer pump, transfer hose, nozzle, and others) is properly grounded and bonded.

WARNING

Avoid static electricity risk when fueling. Ultra-low sulfur diesel fuel (ULSD fuel) poses a greater static ignition hazard than earlier diesel formulations with a higher sulfur contents. Avoid death or serious injury from fire or explosion. Consult with your fuel or fuel system supplier to ensure the delivery system is in compliance with fueling standards for proper grounding and bonding practices.

Inhalation

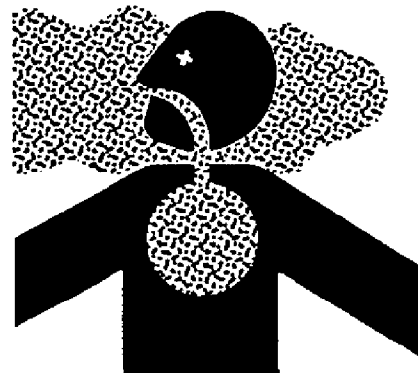

Illustration 16

g00702022

Exhaust

Use caution. Exhaust fumes can be hazardous to health. If you operate the equipment in an enclosed area, adequate ventilation is necessary.

Hexavalent Chromium

Caterpillar equipment and replacement parts comply with applicable regulations and requirements where originally sold. Caterpillar recommends the use of only genuine Caterpillar replacement parts.

Hexavalent chromium has occasionally been detected on exhaust and heat shield systems on Caterpillar engines. Although laboratory testing is the only accurate way to know if hexavalent chromium is, in fact, present, the presence of a yellow deposit in areas of high heat (for example, exhaust system components or exhaust insulation) may be an indication of the presence of hexavalent chromium.

Use caution if you suspect the presence of hexavalent chromium. Avoid skin contact when handling items that you suspect may contain hexavalent chromium, and avoid inhalation of any dust in the suspect area. Inhalation of, or skin contact with, hexavalent chromium dust may be hazardous to your health.

If such yellow deposits are found on the engine, engine component parts, or associated equipment or packages, Caterpillar recommends following local health and safety regulations and guidelines, utilizing good hygiene, and adhering to safe work practices when handling the equipment or parts. Caterpillar also recommends the following:

- Wear appropriate Personal Protective Equipment (PPE)
- Wash your hands and face with soap and water prior to eating, drinking, or smoking, and also during rest room breaks, to prevent ingestion of any yellow powder
- Never use compressed air for cleaning areas suspected of containing hexavalent chromium
- Avoid brushing, grinding, or cutting materials suspected of containing hexavalent chromium
- Obey environmental regulations for the disposal of all materials that may contain or have come into contact with hexavalent chromium
- Stay away from areas that might have hexavalent chromium particles in the air.

Asbestos Information

Caterpillar equipment and replacement parts that are shipped from Caterpillar are asbestos free. Caterpillar recommends the use of only genuine Caterpillar replacement parts. Use the following guidelines when you handle any replacement parts that contain asbestos or when you handle asbestos debris.

Use caution. Avoid inhaling dust that might be generated when you handle components that contain asbestos fibers. Inhaling this dust can be hazardous to your health. The components that may contain asbestos fibers are brake pads, brake bands, lining material, clutch plates, and some gaskets. The asbestos that is used in these components is usually bound in a resin or sealed in some way. Normal handling is not hazardous unless airborne dust that contains asbestos is generated.

If dust that may contain asbestos is present, there are several guidelines that should be followed:

- Never use compressed air for cleaning.
- Avoid brushing materials that contain asbestos.
- Avoid grinding materials that contain asbestos.
- Use a wet method to clean up asbestos materials.
- A vacuum cleaner that is equipped with a high efficiency particulate air filter (HEPA) can also be used.
- Use exhaust ventilation on permanent machining jobs.
- Wear an approved respirator if there is no other way to control the dust.
- Comply with applicable rules and regulations for the work place. In the United States, use Occupational Safety and Health Administration (OSHA) requirements. These OSHA requirements can be found in "29 CFR 1910.1001".
- Obey environmental regulations for the disposal of asbestos.

- Stay away from areas that might have asbestos particles in the air.

Dispose of Waste Properly

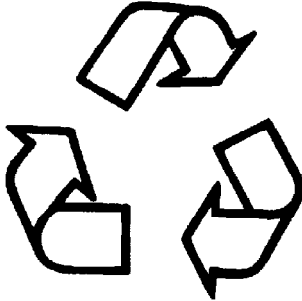

Illustration 17

g00706404

Improperly disposing of waste can threaten the environment. Potentially harmful fluids should be disposed of according to local regulations.

Always use leakproof containers when you drain fluids. Do not pour waste onto the ground, down a drain, or into any source of water.

i07966573

Burn Prevention

SMCS Code: 1000; 7405

Do not touch any part of an operating engine system. The engine, the exhaust, and the engine aftertreatment system can reach temperatures as high as 650° C (1202° F) under normal operating conditions.

Allow the engine system to cool before any maintenance is performed. Relieve all pressure in the air system, hydraulic system, lubrication system, fuel system, and the cooling system before the related items are disconnected.

WARNING

Contact with high pressure fuel may cause fluid penetration and burn hazards. High pressure fuel spray may cause a fire hazard. Failure to follow these inspection, maintenance and service instructions may cause personal injury or death.

After the engine has stopped, wait for 10 minutes to allow the fuel pressure to be purged from the high-pressure fuel lines before any service or repair is performed on the engine fuel lines. The 10 minute wait will also allow static charge to dissipate from the low-pressure fuel system.

Allow the pressure to be purged in the air system, in the hydraulic system, in the lubrication system, or in the cooling system before any lines, fittings, or related items are disconnected.

Induction System

WARNING

Sulfuric Acid Burn Hazard may cause serious personal injury or death.

The exhaust gas cooler may contain a small amount of sulfuric acid. The use of fuel with sulfur levels greater than 15 ppm may increase the amount of sulfuric acid formed. The sulfuric acid may spill from the cooler during service of the engine. The sulfuric acid will burn the eyes, skin and clothing on contact. Always wear the appropriate personal protective equipment (PPE) that is noted on a material safety data sheet (MSDS) for sulfuric acid. Always follow the directions for first aid that are noted on a material safety data sheet (MSDS) for sulfuric acid.

Coolant

When the engine is at operating temperature, the engine coolant is hot. The coolant is also under pressure. The radiator and all lines to the heaters, aftertreatment system or to the engine contain hot coolant.

Any contact with hot coolant or with steam can cause severe burns. Allow cooling system components to cool before the cooling system is drained.

Check that the coolant level after the engine has stopped and the engine has been allowed to cool.

Ensure that the filler cap is cool before removing the filler cap. The filler cap must be cool enough to touch with a bare hand. Remove the filler cap slowly to relieve pressure.

Cooling system conditioner contains alkali. Alkali can cause personal injury. Do not allow alkali to contact the skin, the eyes, or the mouth.

Oils

Skin may be irritated following repeated or prolonged exposure to mineral and synthetic base oils. Refer to your suppliers Material Safety Data Sheets for detailed information. Hot oil and lubricating components can cause personal injury. Do not allow hot oil to contact the skin. Appropriate personal protective equipment should be used.

Diesel Fuel

Diesel engines have high-pressure fuel systems and the fuel can reach temperatures of over 100° C (212° F). Ensure that the fuel has cooled before any service or repairs are performed.

Diesel may be irritating to the eyes, respiratory system, and skin. Prolonged exposure to diesel may cause various skin conditions. Appropriate personal protective equipment should be used. Refer to supplier Material safety Data sheets for detailed information.

Batteries

Electrolyte is an acid. Electrolyte can cause personal injury. Do not allow electrolyte to contact the skin or the eyes. Always wear protective glasses for servicing batteries. Wash hands after touching the batteries and connectors. Use of gloves is recommended.

Engine and Aftertreatment System

Do not touch any part of an operating engine or engine aftertreatment system. Allow the engine or the engine aftertreatment system to cool before any maintenance is performed on the engine or the engine aftertreatment system. Relieve all pressure in the appropriate system before any lines, fittings, or related items are disconnected.

i07966575

Fire Prevention and Explosion Prevention

SMCS Code: 1000; 7405



Illustration 18

g00704000

All fuels, most lubricants, and some coolant mixtures are flammable.

Flammable fluids that are leaking or spilled onto hot surfaces or onto electrical components can cause a fire. Fire may cause personal injury and property damage.

After the emergency stop button is operated, ensure that you allow 15 minutes, before the engine covers are removed.

Determine whether the engine will be operated in an environment that allows combustible gases to be drawn into the air inlet system. These gases could cause the engine to overspeed. Personal injury, property damage, or engine damage could result.

If the application involves the presence of combustible gases, consult your Caterpillar dealer for additional information about suitable protection devices.

Remove all flammable combustible materials or conductive materials such as fuel, oil, and debris from the engine. Do not allow any flammable combustible materials or conductive materials to accumulate on the engine.

Store fuels and lubricants in correctly marked containers away from unauthorized persons. Store oily rags and any flammable materials in protective containers. Do not smoke in areas that are used for storing flammable materials.

Do not expose the engine to any flame.

Exhaust shields (if equipped) protect hot exhaust components from oil or fuel spray if there was a line, a tube, or a seal failure. Exhaust shields must be installed correctly.

Do not weld on lines or tanks that contain flammable fluids. Do not flame cut lines or tanks that contain flammable fluid. Clean any such lines or tanks thoroughly with a nonflammable solvent prior to welding or flame cutting.

Wiring must be kept in good condition. Ensure that all electrical wires are correctly installed and securely attached. Check all electrical wires daily. Repair any wires that are loose or frayed before you operate the engine. Clean all electrical connections and tighten all electrical connections.

Eliminate all wiring that is unattached or unnecessary. Do not use any wires or cables that are smaller than the recommended gauge. Do not bypass any fuses and/or circuit breakers.

Arcing or sparking could cause a fire. Secure connections, recommended wiring, and correctly maintained battery cables will help to prevent arcing or sparking.

WARNING

Contact with high pressure fuel may cause fluid penetration and burn hazards. High pressure fuel spray may cause a fire hazard. Failure to follow these inspection, maintenance and service instructions may cause personal injury or death.

After the engine has stopped, you must wait for 10 minutes to allow the fuel pressure to be purged from the high-pressure fuel lines before any service or repair is performed on the engine fuel lines. The 10 minute wait will also allow static charge to dissipate from the low-pressure fuel system.

Ensure that the engine is stopped. Inspect all lines and hoses for wear or for deterioration. Ensure that the hoses are correctly routed. The lines and hoses must have adequate support and secure clamps. If any fuel lines or fuel hoses become kinked, the fuel line or fuel hose must be replaced. Refer to the Disassembly and Assembly manual for more information.

Oil filters and fuel filters must be correctly installed. The filter housings must be tightened to the correct torque. Refer to the Disassembly and Assembly manual for more information.



Illustration 19

g00704059

Use caution when you are refueling an engine. Do not smoke while you are refueling an engine. Do not refuel an engine near open flames or sparks. Always stop the engine before refueling.

Avoid static electricity risk when fueling. Ultra-low Sulfur Diesel fuel (ULSD fuel) poses a greater static ignition hazard than earlier diesel formulations with a higher sulfur content. Avoid death or serious injury from fire or explosion. Consult your fuel or fuel system supplier to ensure that the delivery system is in compliance with fueling standards for proper grounding and bonding practices.

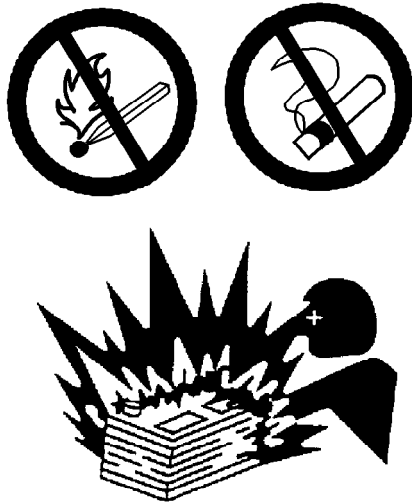

Illustration 20

g00704135

Gases from a battery can explode. Keep any open flames or sparks away from the top of a battery. Do not smoke in battery charging areas.

Never check the battery charge by placing a metal object across the terminal posts. Use a voltmeter or a hydrometer.

Incorrect jumper cable connections can cause an explosion that can result in injury. Refer to the Operation Section of this manual for specific instructions.

Do not charge a frozen battery. A frozen battery may cause an explosion.

The batteries must be kept clean. The covers (if equipped) must be kept on the cells. Use the recommended cables, connections, and battery box covers when the engine is operated.

Fire Extinguisher

Make sure that a fire extinguisher is available. Be familiar with the operation of the fire extinguisher. Inspect the fire extinguisher and service the fire extinguisher regularly. Obey the recommendations on the instruction plate.

Ether

WARNING

Do not use aerosol types of starting aids such as ether. Such use could result in an explosion and personal injury.

Ether is flammable and poisonous.

Lines, Tubes, and Hoses

Do not bend high-pressure lines. Do not strike high-pressure lines. Do not install any lines that are damaged.

Leaks can cause fires. Consult your Caterpillar dealer for replacement parts.

Replace the parts if any of the following conditions are present:

- High-pressure fuel line or lines are removed.
- End fittings are damaged or leaking.
- Outer coverings are chafed or cut.
- Wires are exposed.
- Outer coverings are ballooning.
- Flexible parts of the hoses are kinked.
- Outer covers have embedded armor.
- End fittings are displaced.

Make sure that all clamps, guards, and heat shields are installed correctly. During engine operation, correct installation will help to prevent vibration, rubbing against other parts, and excessive heat.

i08162291

Crushing Prevention and Cutting Prevention

SMCS Code: 1000; 7405

Support the component properly when work beneath the component is performed.

Unless other maintenance instructions are provided, never attempt adjustments while the engine is running.

Stay clear of all rotating parts and of all moving parts. Leave the guards in place until maintenance is performed. After the maintenance is performed, reinstall the guards.

Keep objects away from moving fan blades. The fan blades will throw objects or cut objects.

When objects are struck, wear protective glasses to avoid injury to the eyes.

Chips or other debris may fly off objects when objects are struck. Before objects are struck, ensure that no one will be injured by flying debris.

i05768982

Mounting and Dismounting

SMCS Code: 1000; 7405

Do not climb on the engine or the engine aftertreatment system. The engine and aftertreatment system have not been designed with mounting or dismounting locations.

Refer to the OEM for the location of foot and hand holds for your specific application.

i06662133

High Pressure Fuel Lines

SMCS Code: 1274

WARNING

Contact with high pressure fuel may cause fluid penetration and burn hazards. High pressure fuel spray may cause a fire hazard. Failure to follow these inspection, maintenance and service instructions may cause personal injury or death.

The high-pressure fuel lines are the fuel lines that are between the high-pressure fuel pump and the high-pressure fuel manifold and the fuel lines that are between the fuel manifold and cylinder head. These fuel lines are different from fuel lines on other fuel systems.

The different is because of the following items:

- The high-pressure fuel lines are constantly charged with high pressure.
- The internal pressures of the high-pressure fuel lines are higher than other types of fuel system.
- The high-pressure fuel lines are formed to shape and then strengthened by a special process.

Do not step on the high-pressure fuel lines. Do not deflect the high-pressure fuel lines. Do not bend or strike the high-pressure fuel lines. Deformation or damage of the high-pressure fuel lines may cause a point of weakness and potential failure.

Do not check the high-pressure fuel lines with the engine or the starting motor in operation. After the engine has stopped, you must wait for 10 minutes to allow the fuel pressure to be purged from the high-pressure fuel lines before any service or repair is performed on the engine fuel lines. The 10 minute wait will also allow static charge to dissipate from the low-pressure fuel system.

Do not loosen the high-pressure fuel lines to remove air from the fuel system. This procedure is not required.

Visually inspect the high-pressure fuel lines before the engine is started. This inspection should be each day.

If you inspect the engine in operation, always use the proper inspection procedure to avoid a fluid penetration hazard. Refer to Operation and Maintenance Manual, "General hazard Information".

- Inspect the high-pressure fuel lines for damage, deformation, a nick, a cut, a crease, or a dent.
- Do not operate the engine with a fuel leak. If there is a leak, do not tighten the connection to stop the leak. The connection must only be tightened to the recommended torque. Refer to Disassembly and Assembly, "Fuel injection lines - Remove and Fuel injection lines - Install".
- If the high-pressure fuel lines are torqued correctly and the high-pressure fuel lines are leaking, the high-pressure fuel lines must be replaced.
- Ensure that all clips on the high-pressure fuel lines are in place. Do not operate the engine with clips that are damaged, missing, or loose.
- Do not attach any other item to the high-pressure fuel lines.
- Loosened high-pressure fuel lines must be replaced. Also removed high-pressure fuel lines must be replaced. Refer to Disassembly and assembly manual, "Fuel Injection Lines - Install".

Four Cylinder engine

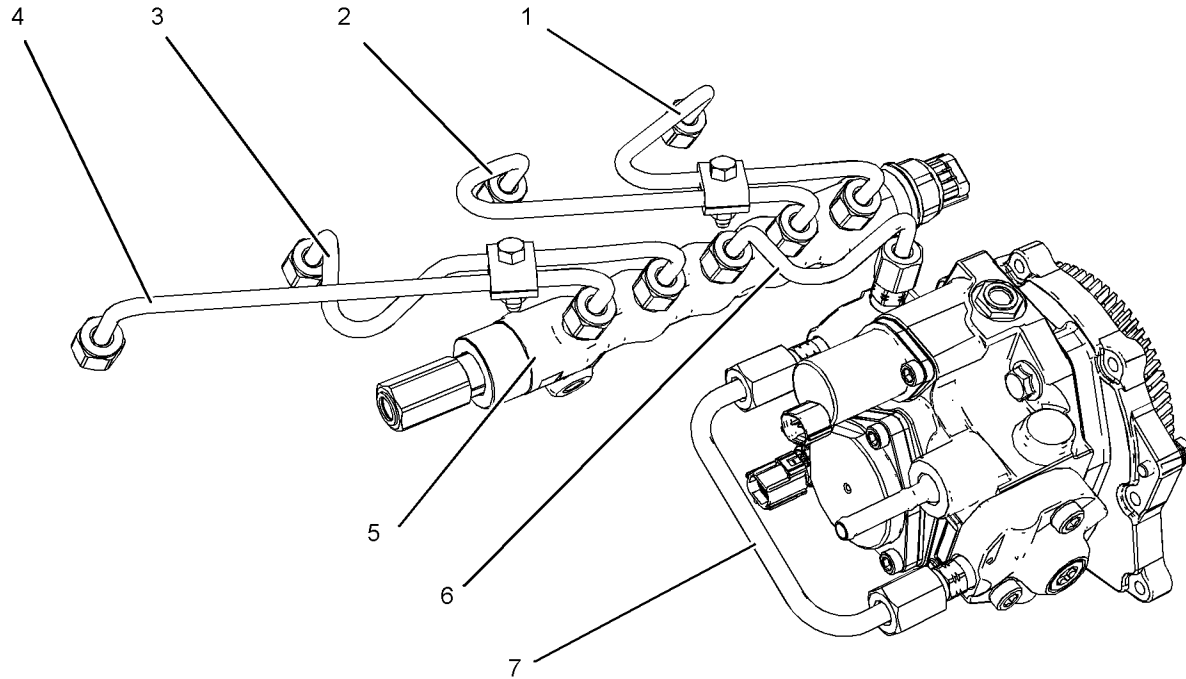

Illustration 21

g03886691

(1) High-pressure line
(2) High-pressure line
(3) High-pressure line

(4) High-pressure line
(5) High-pressure fuel manifold (rail)
(6) High-pressure line

(7) Fuel transfer line that is high pressure

Three Cylinder Engine

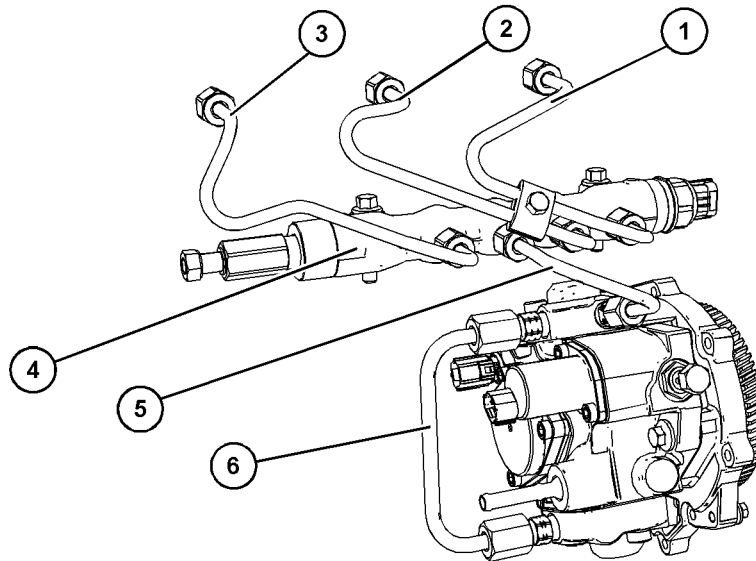

Illustration 22

g06064715

Typical example

(1) High-pressure line
(2) High-pressure line

(3) High-pressure line
(4) High-pressure fuel manifold

(5) High-pressure line
(6) Fuel transfer line that is high pressure

i08614835

Before Starting Engine

SMCS Code: 1000

NOTICE

For initial start-up of a new or rebuilt engine, and for start-up of an engine that has been serviced, make provision to shut the engine off should an overspeed occur. This may be accomplished by shutting off the air and/or fuel supply to the engine.

WARNING

Engine exhaust contains products of combustion which may be harmful to your health. Always start and operate the engine in a well ventilated area and, if in an enclosed area, vent the exhaust to the outside.

Inspect the engine for potential hazards.

Do not start the engine if there is a "DO NOT OPERATE" warning tag or similar warning tag attached to the start switch. Do not move any of the controls if there is a "DO NOT OPERATE" warning tag or similar warning tag attached to the controls.

Before starting the engine, ensure that no one is on, underneath, or close to the engine. Ensure that the area is free of personnel.

If equipped, ensure that the lighting system for the engine is suitable for the conditions. Ensure that all lights work properly, if equipped.

All protective guards and all protective covers must be installed if the engine must be started to perform service procedures. To help prevent an accident that is caused by parts in rotation, work around the parts carefully.

Do not bypass the automatic shutoff circuits. Do not disable the automatic shutoff circuits. The circuits are provided to help prevent personal injury. The circuits are also provided to help prevent engine damage.

See the Service Manual for repairs and for adjustments.

i07905943

i02234873

Engine Starting

SMCS Code: 1000

WARNING

Do not use aerosol types of starting aids such as ether. Such use could result in an explosion and personal injury.

If a warning tag is attached to the engine start switch, or to the controls DO NOT start the engine or move the controls. Consult with the person that attached the warning tag before the engine is started.

All protective guards and all protective covers must be installed if the engine must be started to perform service procedures. To help prevent an accident that is caused by parts in rotation, work around the parts carefully.

Start the engine from the operator's compartment or from the engine start switch.

Always start the engine according to the procedure described in the Operation and Maintenance Manual, "Engine Starting" topic in the Operation Section. Knowing the correct procedure will help to prevent major damage to the engine components. Knowing the procedure will also help to prevent personal injury.

To ensure that the jacket water heater (if equipped) and/or the lube oil heater (if equipped) is working correctly, check the water temperature gauge. Also, check the oil temperature gauge during the heater operation.

Engine exhaust contains products of combustion which can be harmful to health. Always start the engine and operate the engine in a well ventilated area. If the engine is started in an enclosed area, vent the engine exhaust to the outside.

Note: The engine is equipped with a device for cold starting. If the engine will be operated in very cold conditions, an extra cold starting aid may be required. Normally, the engine will be equipped with the correct type of starting aid for the region of operation.

These engines are equipped with a glow plug starting aid in each cylinder which heats the intake air to improve starting.

Engine Stopping

SMCS Code: 1000

Stop the engine according to the procedure in the Operation and Maintenance Manual, "Engine Stopping (Operation Section)" in order to avoid overheating of the engine and accelerated wear of the engine components.

Use the Emergency Stop Button (if equipped) ONLY in an emergency situation. Do not use the Emergency Stop Button for normal engine stopping. After an emergency stop, DO NOT start the engine until the problem that caused the emergency stop has been corrected.

Stop the engine if an overspeed condition occurs during the initial start-up of a new engine or an engine that has been overhauled.

To stop an electronically controlled engine, cut the power to the engine and/or shutting off the air supply to the engine.

i07398900

Electrical System

SMCS Code: 1000; 1400

Never disconnect any charging unit circuit or battery circuit cable from the battery when the charging unit is operating. A spark can cause the combustible gases that are produced by some batteries to ignite.

To help prevent sparks from igniting combustible gases that are produced by some batteries, the negative "-" cable should be connected last from the external power source to the primary position for grounding.

Check the electrical wires daily for wires that are loose or frayed. Tighten all loose electrical connections before the engine is started. Repair all frayed electrical wires before the engine is started. See the Operation and Maintenance Manual for specific starting instructions.

Grounding Practices

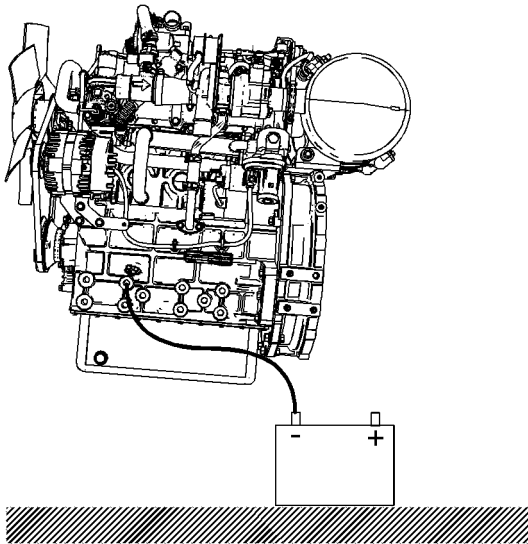

Illustration 23

g06310210

Typical example
Ground to battery

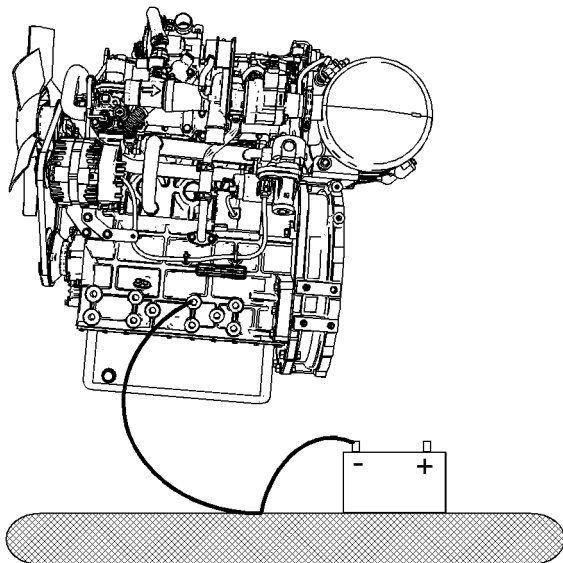

Illustration 24

g06310211

Typical example
Alternate ground to battery

Correct grounding for the engine electrical system is necessary for optimum engine performance and reliability. Incorrect grounding will result in uncontrolled electrical circuit paths and in unreliable electrical circuit paths.

Uncontrolled electrical circuit paths can result in damage to the crankshaft bearing journal surfaces and to aluminum components.

Engines that are installed without engine-to-frame ground straps can be damaged by electrical discharge.

To ensure that the engine and the engine electrical systems function correctly, an engine-to-frame ground strap with a direct path to the battery must be used. This path may be provided by way of a direct engine ground to the frame.

The connections for the grounds should be tight and free of corrosion. The engine alternator must be grounded to the negative “-” battery terminal with a wire that is adequate to handle the full charging current of the alternator.

The power supply connections and the ground connections for the engine electronics should always be from the isolator to the battery.

i08003985

Engine Electronics

SMCS Code: 1000; 1400; 1900

⚠ WARNING

Tampering with the electronic system installation or the OEM wiring installation can be dangerous and could result in personal injury or death and/or engine damage.

⚠ WARNING

Electrical Shock Hazard. The electronic unit injectors use DC voltage. The ECM sends this voltage to the electronic unit injectors. Do not come in contact with the harness connector for the electronic unit injectors while the engine is operating. Failure to follow this instruction could result in personal injury or death.

This engine has a comprehensive, programmable Engine Monitoring System. The Electronic Control Module (ECM) will monitor the engine operating conditions. If any of the engine parameters extend outside an allowable range, the ECM will initiate an immediate action.

The following actions are available for engine monitoring control:

- Warning
- Derate
- Shutdown

The following monitored engine operating conditions and components have the ability to limit engine speed and/or the engine power:

- Engine Coolant Temperature
- Engine Oil Pressure
- Intake Manifold Air Temperature
- Intake Manifold Air Pressure
- Engine Speed Sensors
- Fuel Temperature
- Aftertreatment Temperature Sensors
- Diesel Particulate Filter (DPF) pressure sensor
- Electronic Unit Injectors
- Throttle Valve
- Supply Voltage to Sensors
- Fuel Pressure in Manifold (Rail)
- NOx Reduction System
- Engine Aftertreatment System

The Engine Monitoring package can vary for different engine models and different engine applications. However, the monitoring system and the engine monitoring control will be similar for all engines.

Note: Many of the engine control systems and display modules that are available for Caterpillar Engines will work in unison with the Engine Monitoring System. Together, the two controls will provide the engine monitoring function for the specific engine application. Refer to the Troubleshooting for more information on the Engine Monitoring System.

Product Information Section

Model Views

i09669687

Model View Illustrations

SMCS Code: 1000

The following model views show typical features of the engine and the aftertreatment system. Due to individual applications, your engine, and your aftertreatment may appear different from the illustrations.

Three Cylinder Engine

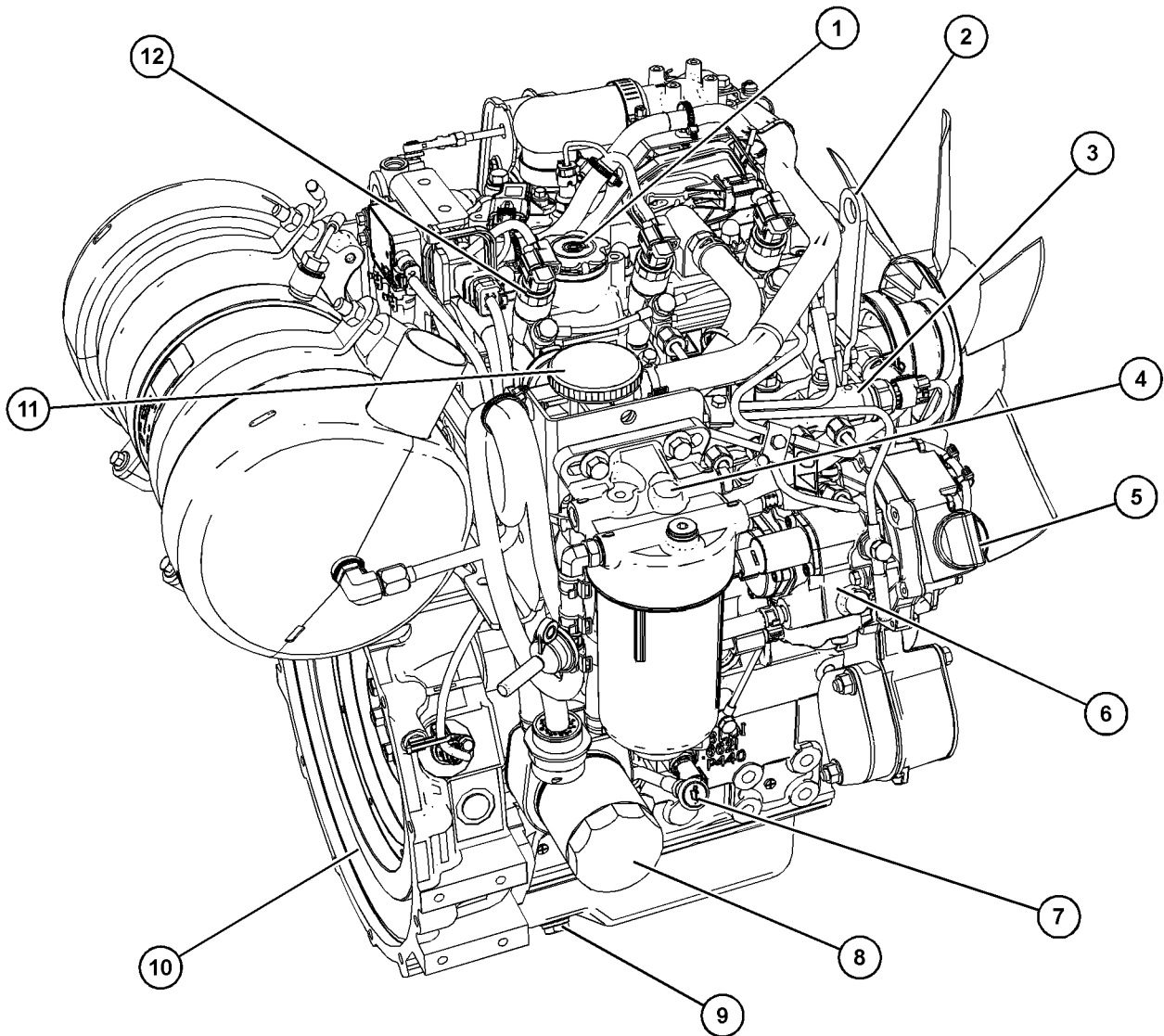

Illustration 25

g06783761

Typical example of a three cylinder engine with closed crankcase breather

- | | | |
|---|--------------------------|---|
| (1) Top oil fill cap | (5) Lower oil filler cap | (10) Flywheel |
| (2) Front lifting eye | (6) Fuel injection pump | (11) Crankcase breather element housing |
| (3) Fuel manifold (rail) | (7) Oil gauge (dipstick) | (12) Electronic unit injector |
| (4) Typical location of fuel filter for shipment only | (8) Oil filter | |
| | (9) Oil drain plug | |

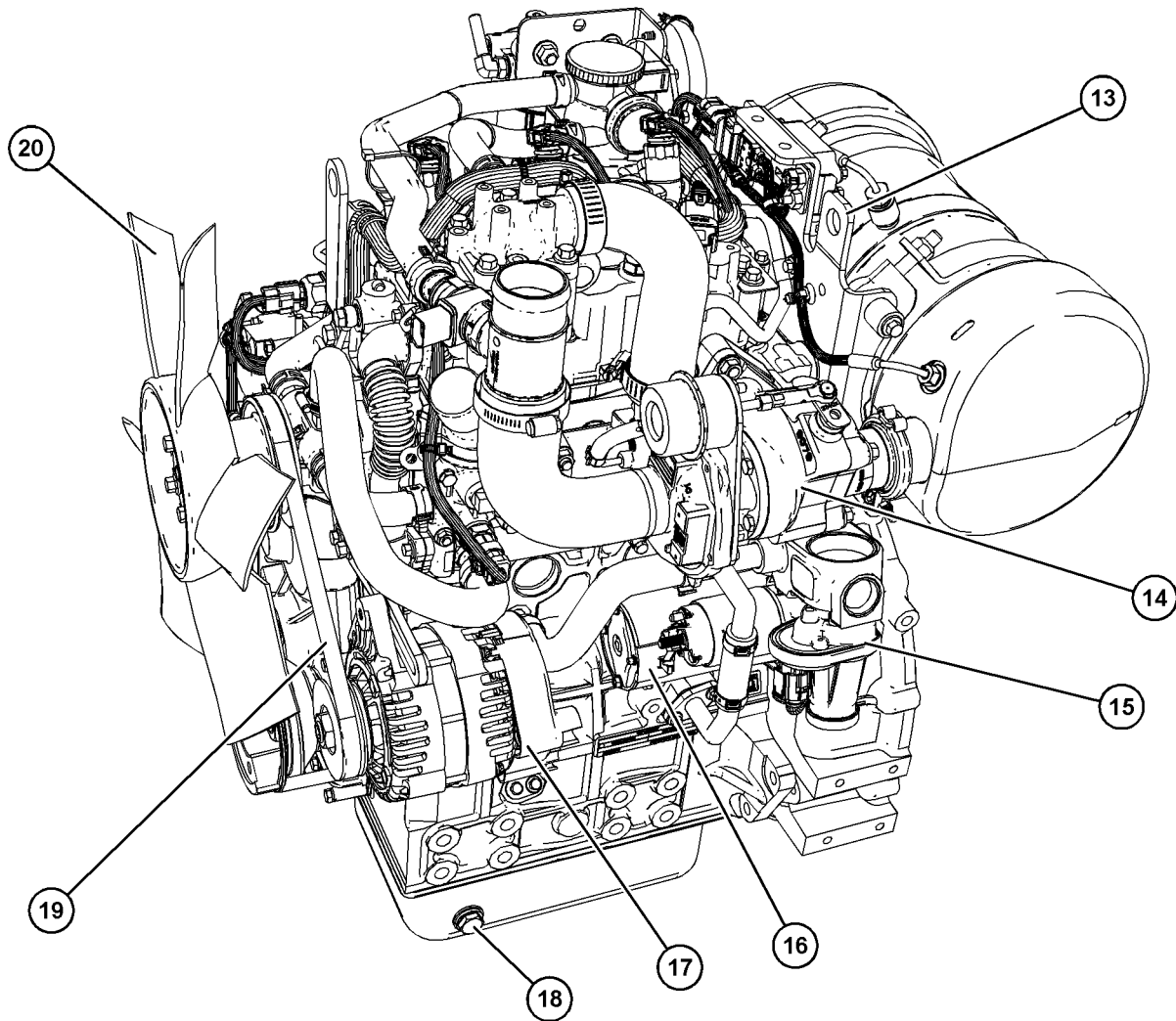

Illustration 26

g06783771

Typical example of a three cylinder engine with closed crankcase breather

(13) Rear lifting eye

(14) Turbocharger

(15) NOx Reduction System (NRS) Valve

(16) Starting motor

(17) Alternator

(18) Oil drain plug

(19) Alternator and fan belt

(20) Fan

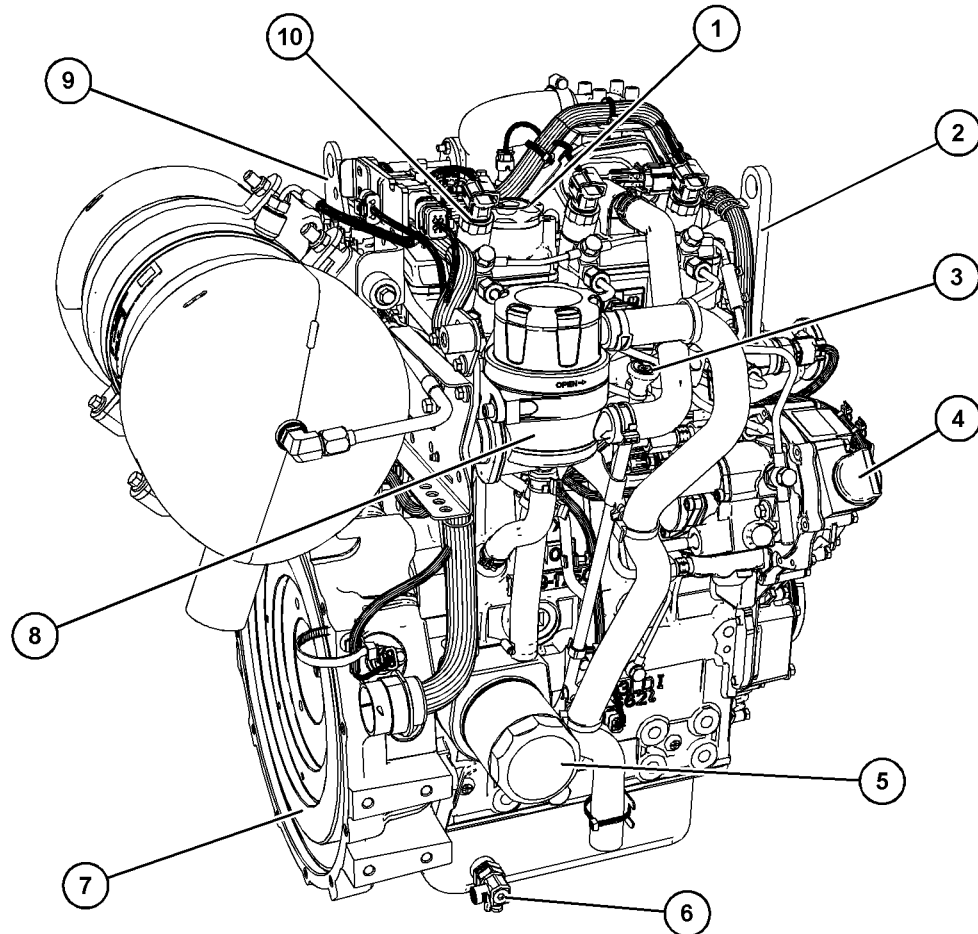

Illustration 27

g06783524

Typical example of a 3 cylinder engine with an open crankcase breather

- | | | |
|--------------------------|--|-------------------------------|
| (1) Top oil fill cap | (5) Oil filter | (9) Rear lifting eye |
| (2) Front lifting eye | (6) Oil drain tap (if equipped) | (10) Electronic unit injector |
| (3) Oil gauge (dipstick) | (7) Flywheel | |
| (4) Lower oil filler cap | (8) Crankcase breather element housing | |

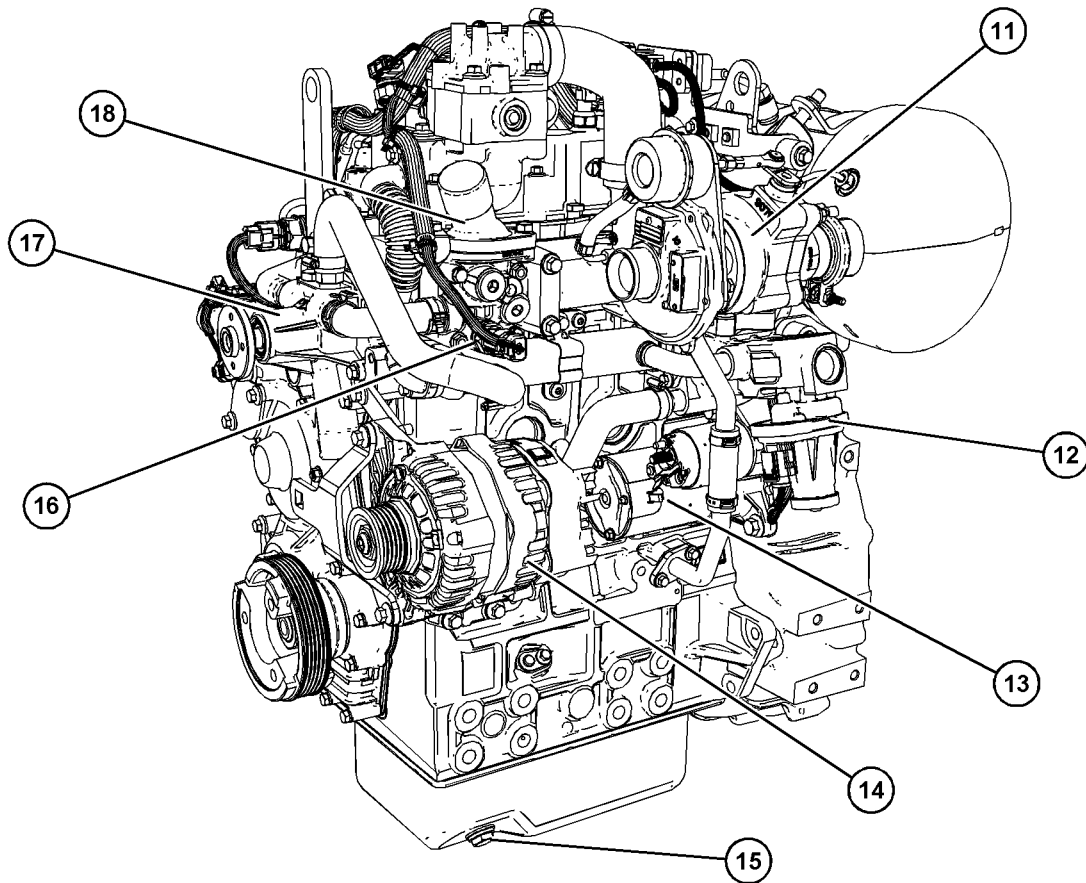

Illustration 28

g06783531

Typical example of a 3 cylinder engine with an open crankcase breather

- | | | |
|---------------------------------------|---------------------------------|--|
| (11) Turbocharger | (14) Alternator | (17) Water pump |
| (12) NOx Reduction System (NRS) Valve | (15) Oil drain plug | (18) Water temperature regulator housing |
| (13) Starting motor | (16) Coolant temperature sensor | |

Four Cylinder Engine

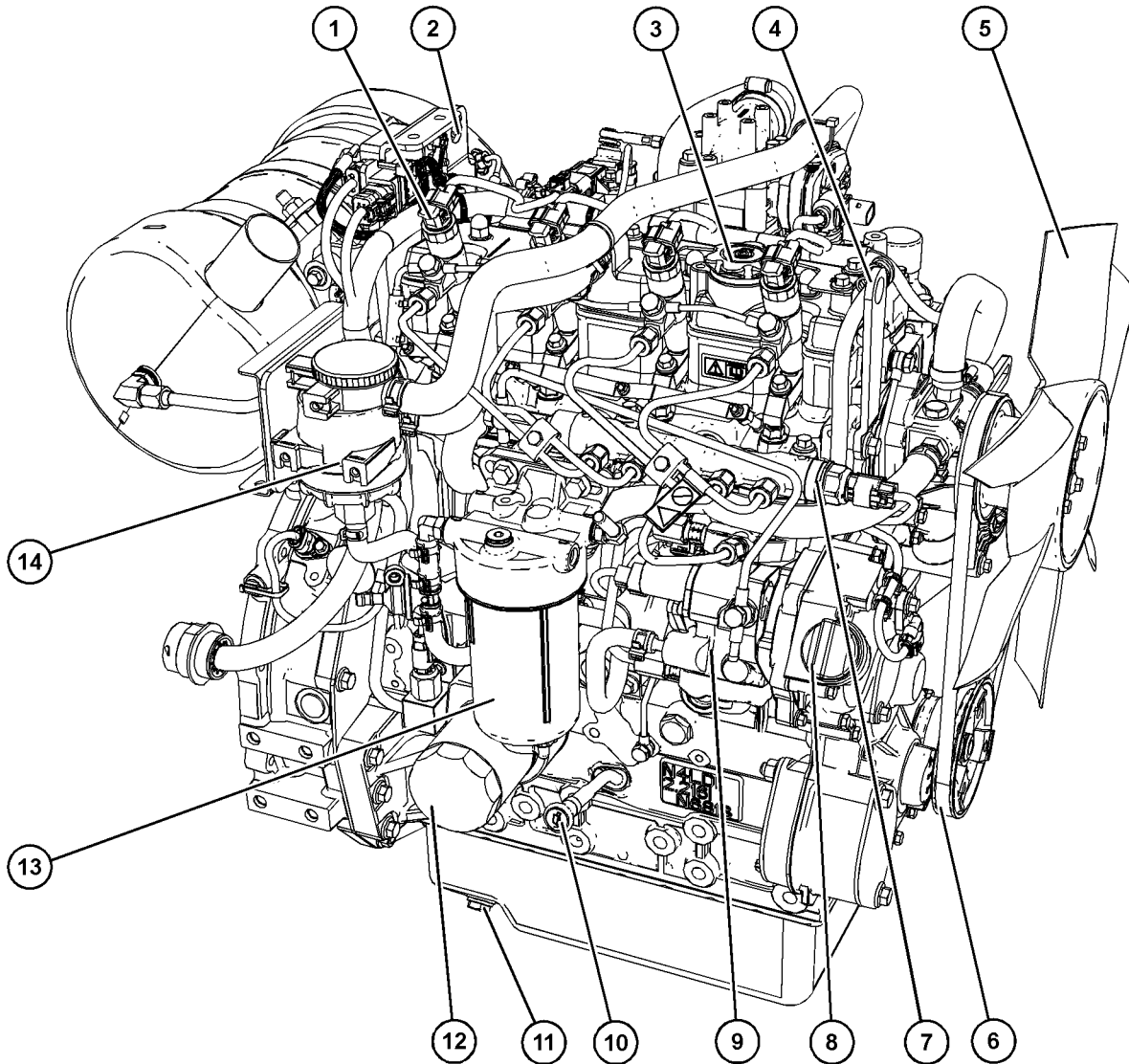

Illustration 29

g06310812

Typical example of a 4 cylinder engine with a closed crankcase breather

- (1) Electronic unit injector
- (2) Rear lifting eye
- (3) Top oil fill cap
- (4) Front lifting eye
- (5) Fan

- (6) Alternator and fan belt
- (7) Fuel manifold (rail)
- (8) Lower oil filler cap
- (9) Fuel injection pump
- (10) Oil gauge (dipstick)

- (11) Oil drain plug
- (12) Oil filter
- (13) Secondary fuel filter
- (14) Closed crankcase breather

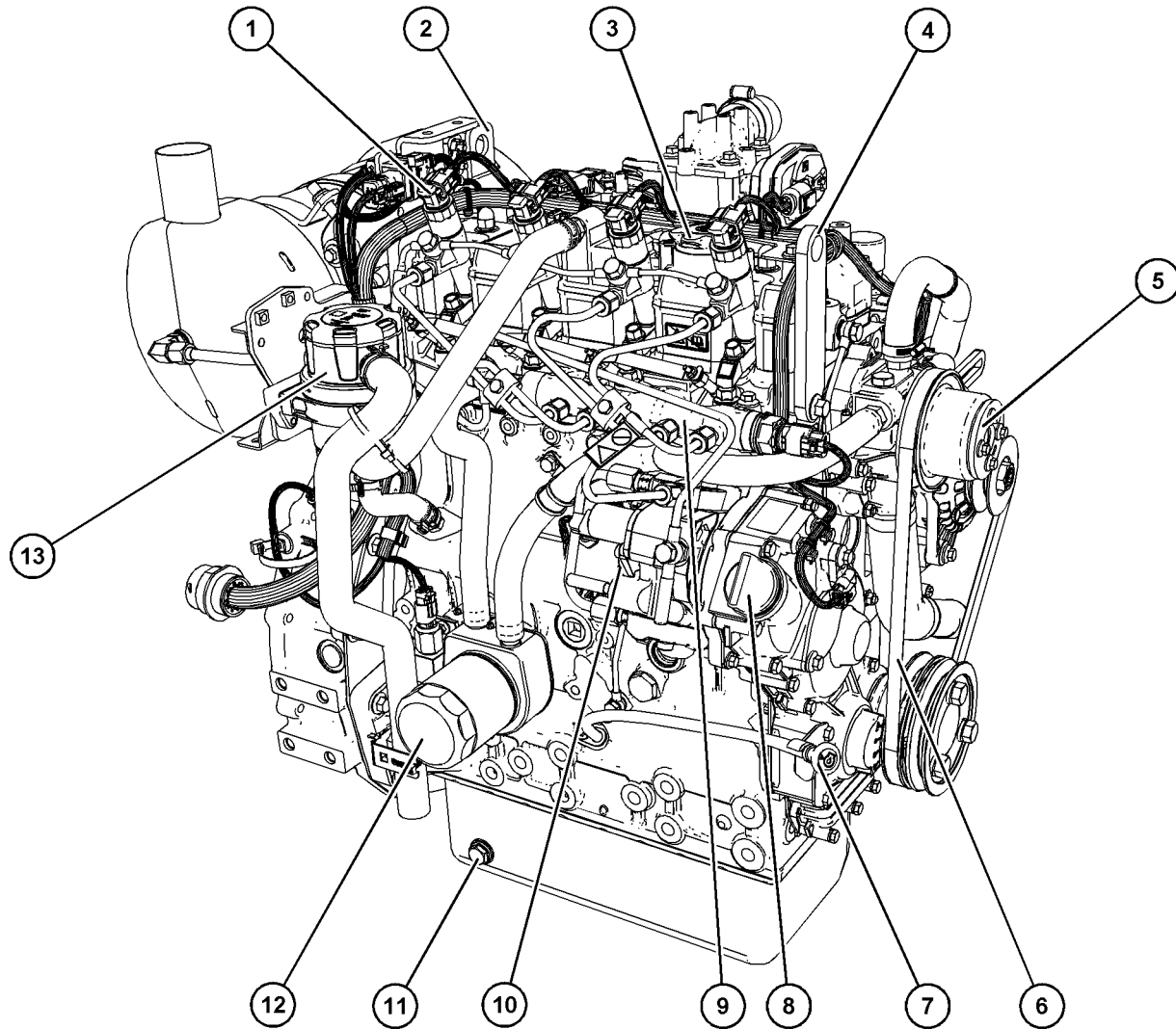

Illustration 30

g06772497

Typical example of a 4 cylinder engine with an open crankcase breather

- | | | |
|------------------------------|-----------------------------|------------------------------|
| (1) Electronic unit injector | (6) Alternator and fan belt | (11) Oil drain plug |
| (2) Rear lifting eye | (7) Oil gauge (dipstick) | (12) Oil filter |
| (3) Top oil fill cap | (8) Lower oil filler cap | (13) Open crankcase breather |
| (4) Front lifting eye | (9) Fuel manifold (rail) | |
| (5) Fan | (10) Fuel injection pump | |

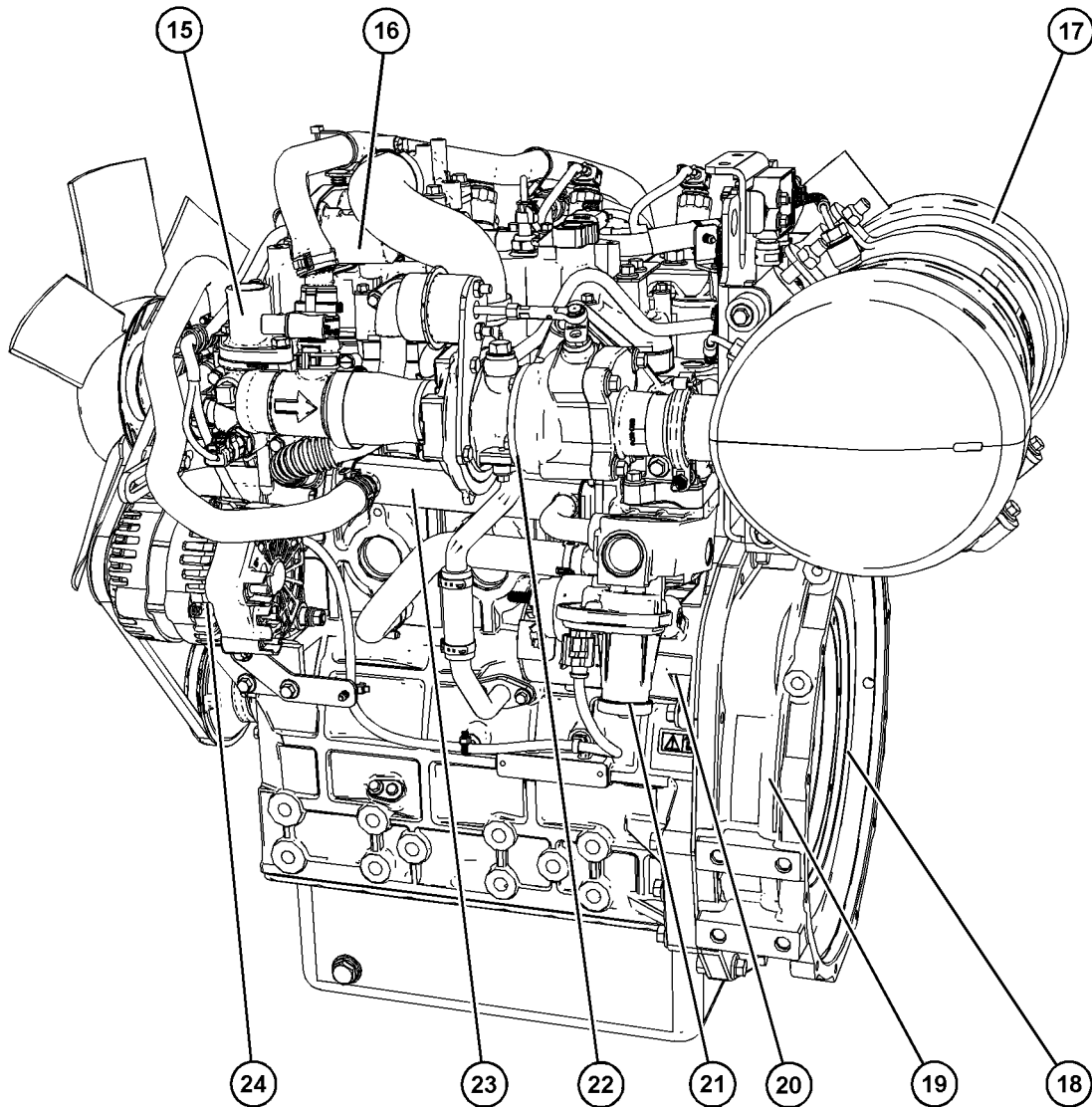

Illustration 31

g06311071

Typical example of a four cylinder engine with closed crankcase breather

- | | | |
|-----------------------------------|---------------------------------------|-----------------|
| (15) Water temperature regulator | (19) Flywheel housing | (23) NRS cooler |
| (16) Throttle valve | (20) Starting motor | (24) Alternator |
| (17) Clean Emissions Module (CEM) | (21) NOx Reduction System (NRS) Valve | |
| (18) Flywheel | (22) Turbocharger | |

Off Engine Components for Three and Four Cylinder Engines

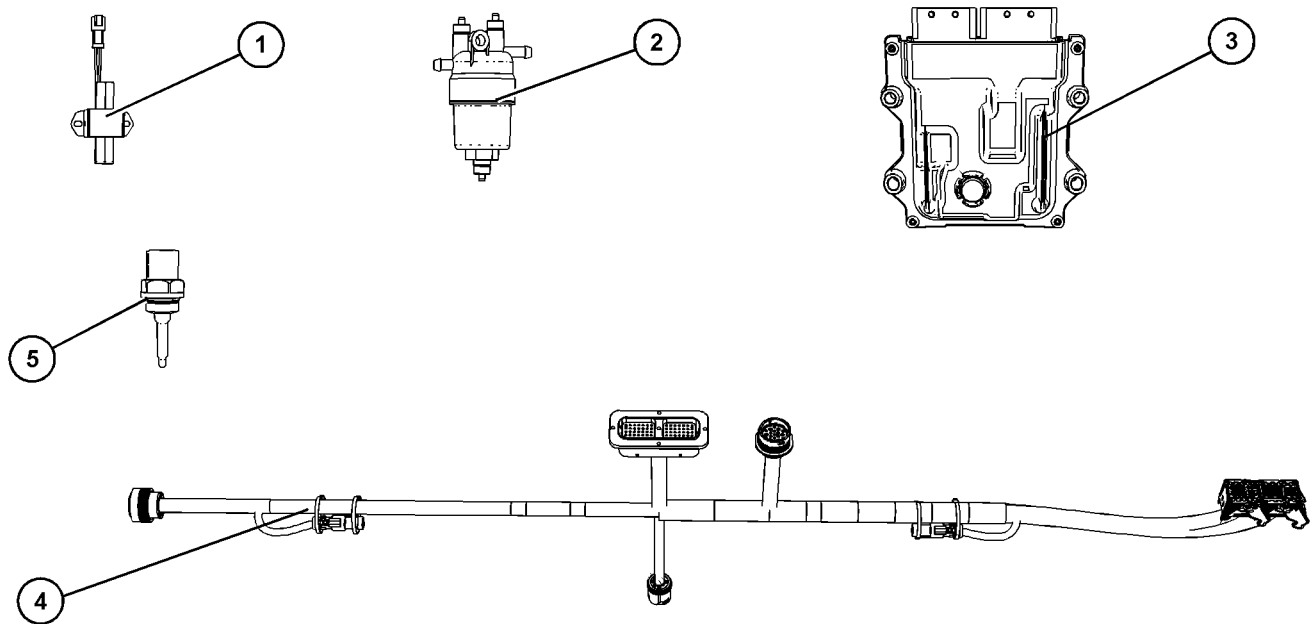

Illustration 32

g06444151

Typical example

(1) Electric fuel priming pump

(2) Primary fuel filter/water separator

(3) Electronic Control Module (ECM)

(4) Engine link wiring harnesses

(5) Inlet air temperature sensor

Open Power Unit (OPU)

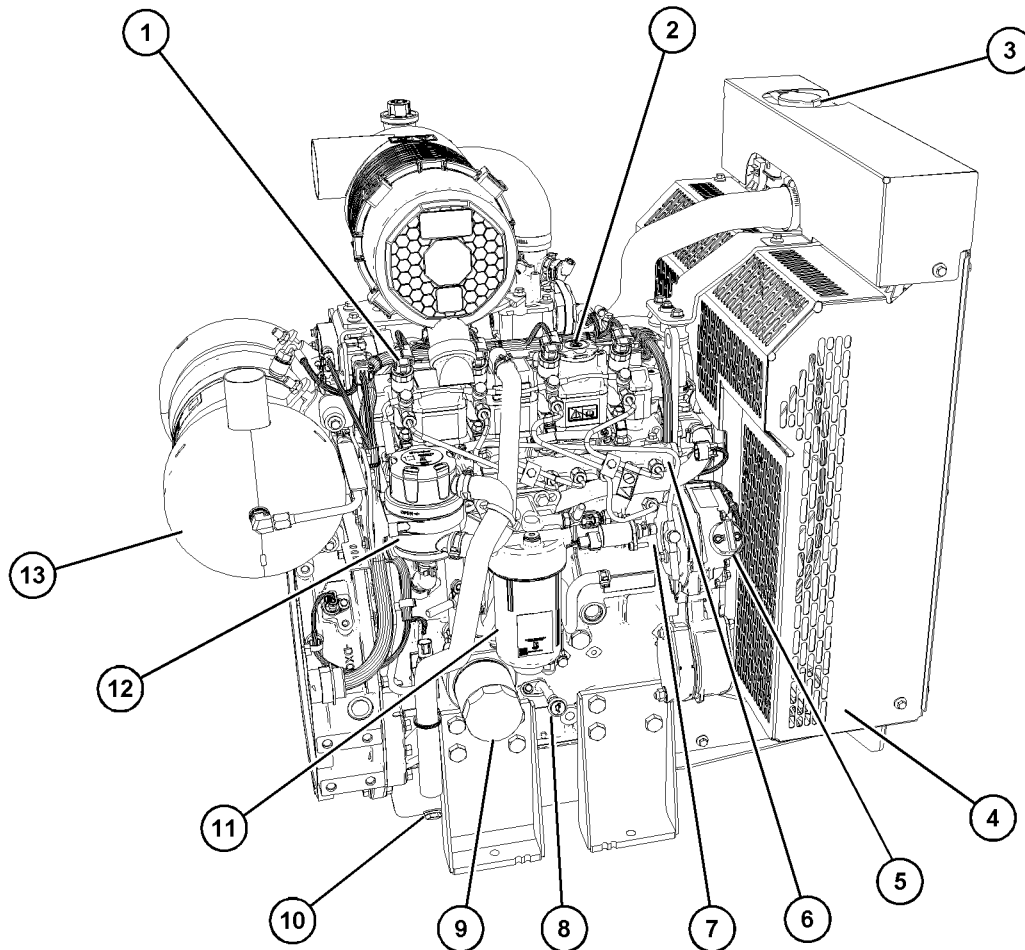

Illustration 33

g07522501

Typical example of a 4 cylinder OPU

- | | | |
|---------------------------------|--------------------------|--|
| (1) Electronic unit injector | (6) Fuel manifold (rail) | (11) Secondary fuel filter/water separator |
| (2) Top oil fill cap | (7) Fuel injection pump | (12) Open crankcase breather |
| (3) Radiator coolant refill cap | (8) Oil gauge (dipstick) | (13) Clean Emissions Module (CEM) |
| (4) Fan guard | (9) Oil filter | |
| (5) Lower oil filler cap | (10) Oil drain plug | |

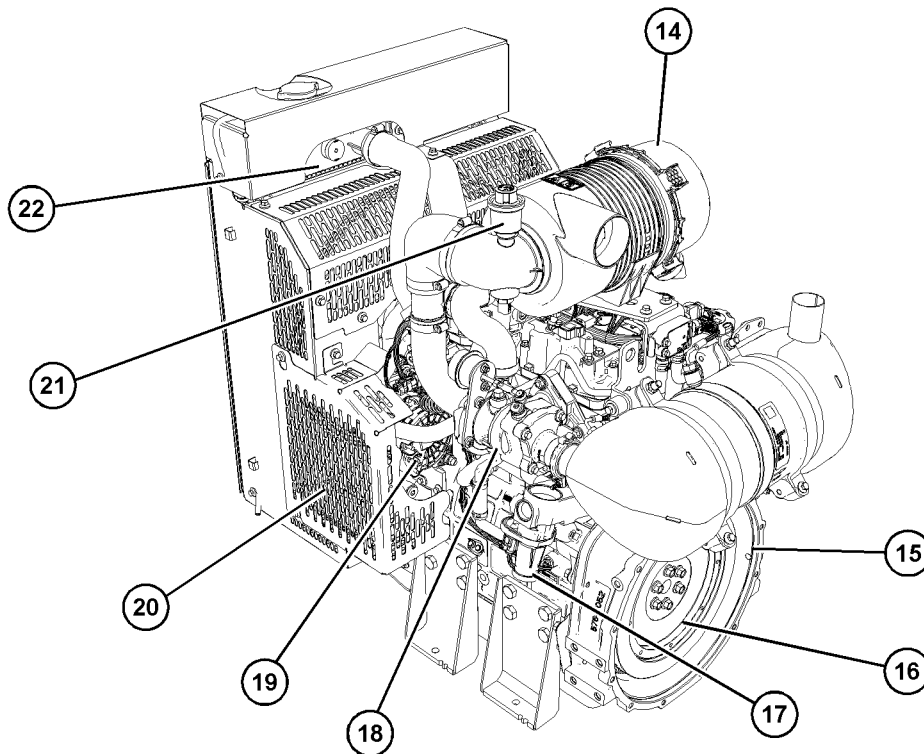

Illustration 34

g07522507

Typical example of a 4 cylinder OPU

(14) Engine air cleaner
 (15) Flywheel housing
 (16) Flywheel

(17) NOx Reduction System (NRS) Valve
 (18) Turbocharger
 (19) Alternator

(20) Service panel
 (21) Engine air cleaner service indicator
 (22) Radiator

Off Engine Components for Three and Four Cylinder OPU

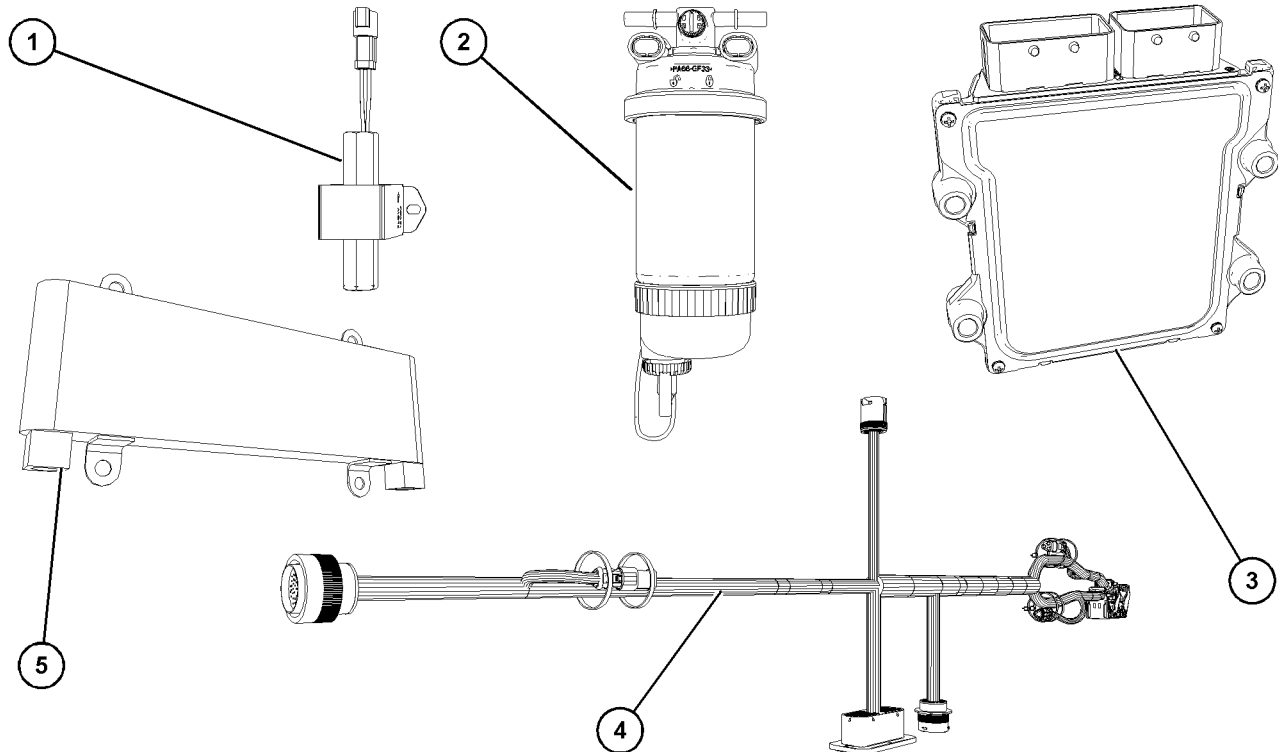

Illustration 35

g07522512

Typical example

(1) Electric fuel priming pump

(2) Primary fuel filter/water separator

(3) Electronic Control Module (ECM)

(4) Engine link wiring harnesses

(5) Fuel cooler

i07966584

Product Description

SMCS Code: 1000; 4450; 4491; 7000

Three Cylinder Engine C1.7

The Caterpillar C1.7 industrial engine is a turbocharged engine. The engine is electronically governed.

The C1.7 industrial engine has the following characteristics.

- In-line 3 cylinder
- 4 stroke cycle
- Two valves per cylinder

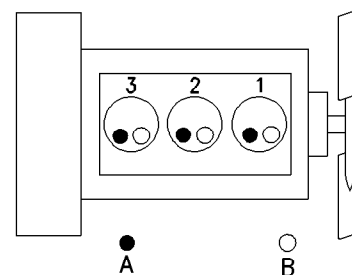

Illustration 36

g00852304

(A) Exhaust valves

(B) Inlet valves

Table 1

C1.7 Engine Specifications	
Maximum Operating Speed (rpm)	2800 RPM
Cylinders and Arrangement	In-Line three cylinder engine
Bore	84 mm (3.31 inch)
Stroke	100 mm (3.94 inch)
Displacement	1.66 L (101.3 in ³)
Aspiration	Turbocharged
Compression Ratio	17:1
Firing Order	1-2-3
Rotation (flywheel end)	Counterclockwise
Valve Lash Setting (Inlet)	0.20 mm (0.008 inch)
Valve Lash Setting (Exhaust)	0.20 mm (0.008 inch)

Four Cylinder Engine C2.2

Two variants of C2.2 industrial engine are available, the turbocharged engine and the turbocharged charge cooled engine. Both engine variants are electronically governed.

The C2.2 industrial engines have the following characteristics.

- In-line 4 cylinder
- 4 stroke cycle
- Two valves per cylinder

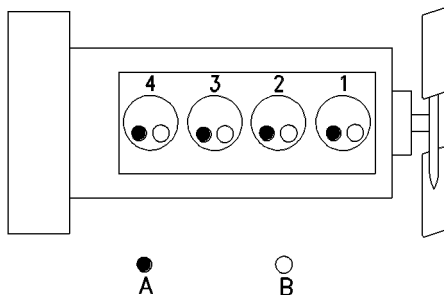

Illustration 37

g00296424

(A) Exhaust valves
(B) Inlet valves

Table 2

C2.2 Industrial Engines	
Maximum Operating Speed (rpm)	2800 RPM
Cylinders and Arrangement	In-Line four cylinder engine
Bore	84 mm (3.307 inch)
Stroke	100 mm (3.937 inch)
Displacement	2.216 L (135.2 cubic inch)
Compression Ratio	17: 1
Aspiration	Turbocharged and Turbo-charged charge/air cooled
Valve Lash Setting (Inlet)	0.20 mm (0.008 inch)
Valve Lash Setting (Exhaust)	0.20 mm (0.008 inch)
Firing Order	1-3-4-2
Rotation (flywheel end)	Counterclockwise

Aftertreatment System

Both the three and four cylinder engines have the same aftertreatment system.

The aftertreatment system is approved for use by Caterpillar. To be emission-compliant, only the approved Caterpillar aftertreatment system must be used on a Caterpillar engine.

Clean Emission Module (CEM)

The CEM comprises of two main components in a single unit, the Diesel Oxidation Catalyst (DOC) and the Diesel Particulate Filter (DPF). The function of the CEM is to ensure that the engine exhaust meets the required emissions regulation for the country of operation.

The exhaust gases pass through the DOC to remove contaminants, carbon monoxide, and hydrocarbons. The exhaust gases then enter the DPF where any particulate matter soot and ash will be trapped.

The CEM uses a passive and active regeneration process to ensure that normal operation of the engine removes the soot. The soot is removed at an equal rate of which the soot is captured. The ash remains in the DPF.

Electronic Engine Features

The engine operating conditions are monitored. The Electronic Control Module (ECM) controls the response of the engine to these conditions and to the demands of the operator. These conditions and operator demands determine the precise control of fuel injection by the ECM. The electronic engine control system provides the following features:

- Engine monitoring
- Engine speed governing
- Injection timing control
- System diagnostics

Engine Diagnostics

The engine has built-in diagnostics to ensure that the engine systems are functioning correctly. The operator will be alerted to the condition by a “Stop” or “Warning” lamp. Under certain conditions, the engine horsepower, the engine speed, and the vehicle speed may be limited. The electronic service tool may be used to display the diagnostic codes.

There are four types of diagnostic codes: Active Diagnostic Code, Logged Diagnostic Code, Active Event Code, and Logged Event Code.

The ECM provides an electronic governor that controls the injector output to maintain the desired engine RPM.

Service Life

Engine efficiency and maximum utilization of engine performance depend on the adherence to proper operation and maintenance recommendations. In addition, use recommended fuels, coolants, and lubricants. Use the Operation and Maintenance Manual as a guide for required engine maintenance.

Expected engine life is generally predicted by the average power that is demanded. The average power that is demanded is based on fuel consumption of the engine over a period of time. Reduced hours of operation at full throttle and/or operating at reduced throttle settings result in a lower average power demand.

The aftertreatment system can be expected to function properly for the useful life of the engine (emissions durability period), as defined by regulation, subject to prescribed maintenance requirements being followed.

Aftermarket Products and Caterpillar Engines

Caterpillar does not warrant the quality or performance of non-Caterpillar fluids and filters.

When auxiliary devices, accessories, or consumables (filters, additives, catalysts), which are made by other manufacturers are used on Caterpillar products, the Caterpillar warranty is not affected simply because of such use.

However, failures that result from the installation or use of other manufacturers devices, accessories, or consumables are NOT Caterpillar defects. Therefore, the defects are NOT covered under the Caterpillar warranty.

Product Identification Information

i06506213

Plate Locations and Film Locations

SMCS Code: 1000

Serial Number Plate

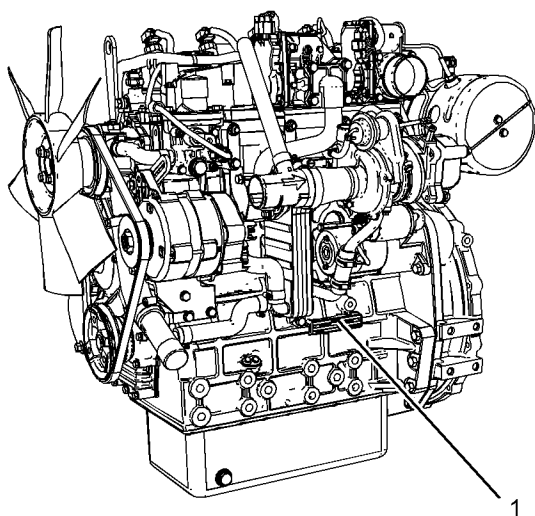

Illustration 38

g03882431

The engine serial plate (1) is on the left side of the engine to the rear of the engine cylinder block.

Caterpillar engines are identified by serial numbers and by arrangement numbers. These numbers are shown on the engine serial number plate. Cat dealers need these numbers to determine the components that were included with the engine.

This action permits accurate identification of replacement part numbers

Plate

CATERPILLAR®		CAT®	
○ SERIAL NUMBER	ARRANGEMENT NUMBER	MODEL	○
ASSEMBLED IN		(ALWAYS GIVE ALL NUMBERS)	
		246-4291	

Illustration 39

g01131696

Serial number plate

i06280422

Reference Information

SMCS Code: 1000; 1400; 4450; 7000

Information for the following items may be needed to order parts. Locate the information for your engine. Record the information in the appropriate space. Make a copy of this list for a record. Keep the information for future reference.

Record for Reference

Engine Model _____

Engine Serial number _____

Engine Low Idle rpm _____

Engine Full Load rpm _____

Primary Fuel Filter _____

Secondary Fuel Filter Element _____

Lubrication Oil Filter Element _____

Auxiliary Oil Filter Element (if Equipped) _____

Total Lubrication System Capacity _____

Total Cooling System Capacity _____

Air Cleaner Element _____

Drive Belt _____

Operation Section

Lifting and Storage

i09669704

Product Lifting

SMCS Code: 1000; 1404; 7002

NOTICE

Always inspect lifting eyebolts and all other lifting equipment for damage before performing any lifting. Never bend the eyebolts and the brackets. Never perform product lifting if components are damaged. Only load the eyebolts and the brackets under tension. Remember that the capacity of an eyebolt is less as the angle between the supporting members and the object becomes less than 90 degrees.

When it is necessary to remove a component at an angle, only use a link bracket that is properly rated for the weight.

Use a hoist to remove heavy components. Use an adjustable lifting beam to lift the engine. All supporting members (chains and cables) should be parallel to each other. The chains and cables should be perpendicular to the top of the object that is being lifted.

To obtain the correct balance for lifting an application, adjust the chain lengths.

Lifting eyes are designed and installed for the specific engine arrangement. Alterations to the lifting eyes and/or the engine make the lifting eyes and the lifting fixtures obsolete. If alterations are made, ensure that proper lifting devices are provided.

There are several different designs of lifting eyes. The following sections give examples of lifting eyes on the engine and aftertreatment, and Open Power Unit (OPU).

Consult your Caterpillar dealer for information regarding fixtures for proper lifting.

Engine and Aftertreatment

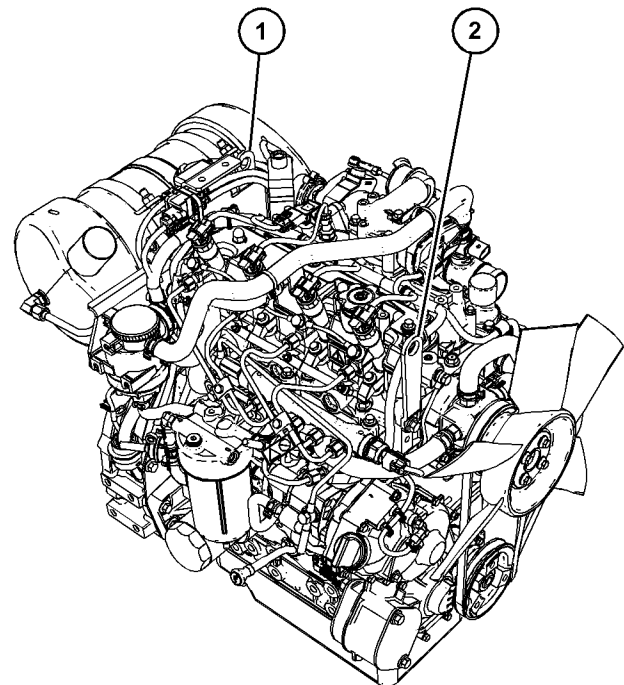

Illustration 40

g06310634

Lifting eyes for the engine and aftertreatment only.

- (1) Rear lifting eye
- (2) Front lifting eye

Open Power Unit (OPU)

NOTICE

Damage may occur to the engine air cleaner during the lifting of the OPU. It is recommended that the engine air cleaner is removed before lifting the OPU. Refer to Disassembly and Assembly Manual, "Air Cleaner Housing - Remove and Install".

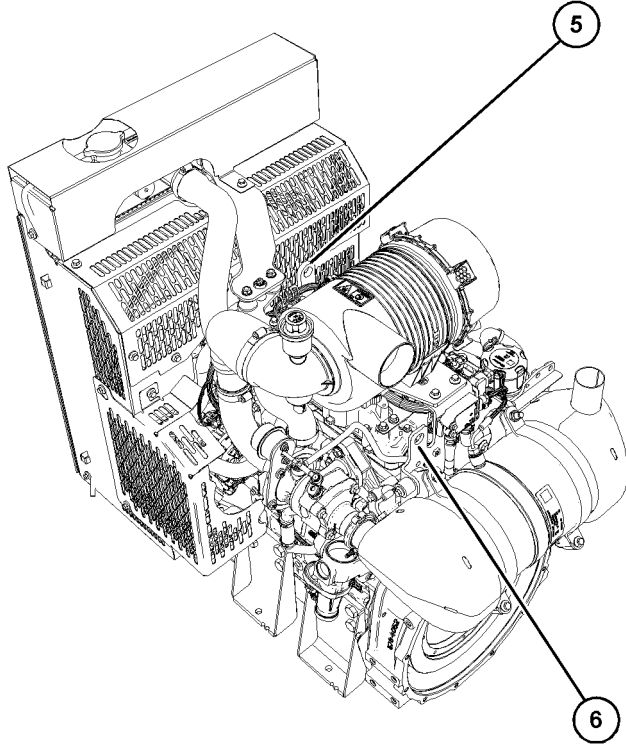

Illustration 41

g07521889

Typical example of lifting eyes for 4 cylinder OPU

- (5) Front lifting eye
- (6) Rear lifting eye

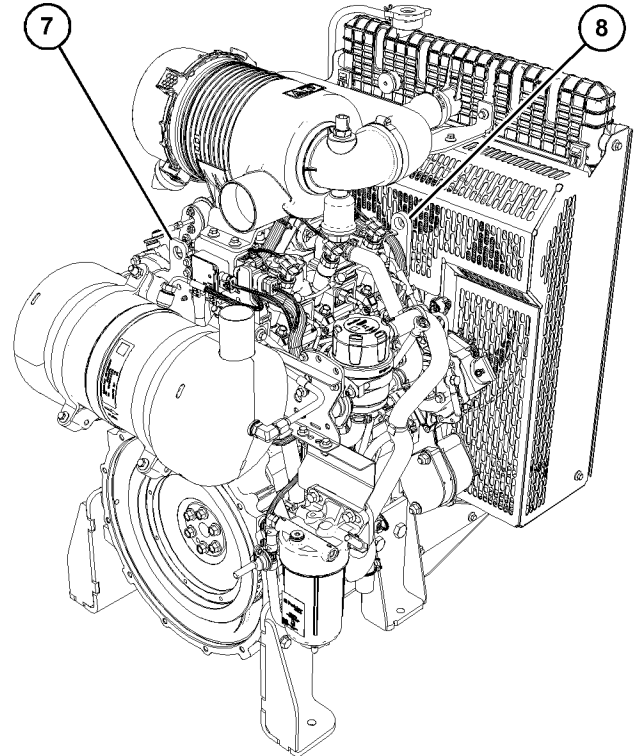

Illustration 42

g07521915

Typical example of lifting eyes for 3 cylinder OPU

- (7) Rear lifting eye
- (8) Front lifting eye

Remove the engine air cleaner on both types of OPU before attaching any lifting equipment.

i08267190

Product Storage

SMCS Code: 1000; 1404; 7002

If the engine will not be started for several weeks, the lubricating oil will drain from the cylinder walls and from the piston rings. Rust can form on the cylinder liner surface. Rust on the cylinder liner surface will cause increased engine wear and a reduction in engine service life.

To help prevent excessive engine wear, use the following guidelines:

- Complete all lubrication recommendations that are listed in this Operation and Maintenance Manual, "Maintenance Interval Schedule" (Maintenance Section).
- If freezing temperatures are expected, check the cooling system for adequate protection against freezing. See this Operation and Maintenance Manual, "Refill Capacities and Recommendations" (Maintenance Section).

If an engine is out of operation and if use of the engine is not planned, special precautions should be made. If the engine will be stored for more than 1 month, a complete protection procedure is recommended.

For more detailed information on engine storage, see Special Instruction, SEHS9031, "Storage Procedure For Caterpillar Products".

Your Cat dealer can help in preparing the engine for extended storage periods.

Gauges and Indicators

i09669988

Gauges and Indicators

SMCS Code: 1900; 7450

Your engine may not have the same gauges or all the gauges that are described. For more information about the gauge package, see the OEM information.

Gauges provide indications of engine performance. Ensure that the gauges are in good working order. Determine the normal operating range by observing the gauges over a period of time.

Noticeable changes in gauge readings indicate potential gauge or engine problems. Problems may also be indicated by gauge readings that change even if the readings are within specifications. Determine and correct the cause of any significant change in the readings. Consult your Cat dealer for assistance.

NOTICE

If no oil pressure is indicated, STOP the engine. If maximum coolant temperature is exceeded, STOP the engine. Engine damage can result.



Engine Oil Pressure – The oil pressure should be greatest after a cold engine is started. The typical engine oil pressure with SAE10W30 is 207 kPa to 413 kPa (30 psi to 60 psi) at rated rpm.

A lower oil pressure is normal at low idle. If the load is stable and the gauge reading changes, perform the following procedure:

1. Remove the load.
2. Reduce engine speed to low idle.
3. Check and maintain the oil level.



Jacket Water Coolant Temperature – Typical temperature range is 82° to 96°C (147.6° to 172.8°F). The maximum allowable temperature with the pressurized cooling system at 90 kPa (13 psi) is 112° C (233.6° F). Higher temperatures may occur under certain conditions. The water temperature reading may vary according to load. The reading should never exceed the boiling point for the pressurized system that is being used.

If the engine is operating above the normal range and steam becomes apparent, perform the following procedure:

1. Reduce the load and the engine rpm.
2. Inspect the cooling system for leaks.

3. Determine if the engine must be shut down immediately or if the engine can be cooled by reducing the load.



Tachometer – This gauge indicates engine speed (rpm). When the throttle control lever is moved to the full throttle position without load, the engine is running at high idle. The engine is running at the full load rpm when the throttle control lever is at the full throttle position with maximum rated load.

NOTICE

To help prevent engine damage, never exceed the high idle rpm. Overspeeding can result in serious damage to the engine. The engine can be operated at high idle without damage, but should never be allowed to exceed high idle rpm.



Engine - Electrical Preheat – This indicator comes “ON” to show that the glow plug preheat is active. The engine should be set to “RUN” only after indicator lamp on the display turns “OFF” .



Ammeter – This gauge indicates the amount of charge or discharge in the battery charging circuit. Operation of the indicator should be to the right side of “0” (zero).



Fuel Level – This gauge indicates the fuel level in the fuel tank. The fuel level gauge operates when the “START/STOP” switch is in the “ON” position.



Service Hour Meter – The gauge indicates operating time of the engine.

Indicators and Lamps

- Shutdown lamp
- Warning lamp
- Low-pressure oil lamp
- Wait to start lamp

For more information on indicator lamps refer to this Operation and Maintenance Manual, “Monitoring System (Table for Indicators Lamps)”. All lamps will be illuminated for 2 seconds to check that the lamps are functioning when the keyswitch is turned to the ON position. Any lamp that fails to illuminate during the first 2 second must be replaced. If any of the lamps stay illuminated, the reason must be investigated immediately.

Features and Controls

i06280431

Monitoring System (Engine Warning Indicators)

SMCS Code: 1900; 7400; 7402; 7450; 7451

Table 3

Table for Warning Indicators					
Warning Indicator	Shutdown Indicator	Indicator State	Description of the Indication	Engine Status	Operator Action
ON	ON	Indicator Check	Keyswitch in the ON position all Indicators should illuminate for 0.5 of a second.	Power ON, Indicator check Engine is not operating.	If any of the Indicators will not illuminate during the Indicator check, the fault must be investigated immediately. If any Indicator stays illuminated or flash, the fault must be investigated immediately.
OFF	OFF	No Fault	-	Engine operating normally.	None
Level 1					
ON (Solid)	OFF	Level 1	An active diagnostic code is present.	The engine is operating, but one or more diagnostic codes are present.	As soon as possible the diagnostic code should be investigated.
Level 2					
Flashing	OFF	Level 2	The ECM has detected an abnormal condition.	If enabled, the engine will be derated.	Stop the engine. Investigate the fault.
Level 3					
Flashing	ON	Level 3	Engine condition is abnormal.	The engine will automatically shutdown. If shutdown is not enabled, the engine can operate but may cause damage .	Stop engine immediately. Investigate the fault.

i07966619

Monitoring System

SMCS Code: 1900; 7400; 7402; 7450; 7451

WARNING

If the Shutdown mode has been selected and the warning indicator activates, engine shutdown may take as little as 20 seconds from the time the warning indicator is activated. Depending on the application, special precautions should be taken to avoid personal injury. The engine can be re-started following shutdown for emergency maneuvers, if necessary.

NOTICE

The Engine Monitoring System is not a guarantee against catastrophic failures. Programmed delays and derate schedules are designed to minimize false alarms and provide time for the operator to stop the engine.

The following parameters are monitored:

- Engine speed/timing
- Temperature and pressures sensors
- Atmospheric pressure (Barometric pressure)
- Battery voltage
- Differential pressure in the diesel particulate filter
- The amount of soot in the diesel particulate filter

Programmable Options and Systems Operation

WARNING

If the Warning/Derate/Shutdown mode has been selected and the warning indicator activates, bring the engine to a stop whenever possible. Depending on the application, special precautions should be taken to avoid personal injury.

The engine can be programmed to the following modes:

“Warning”

The orange “Warning” lamp will turn “ON” and the warning signal is activated continuously to alert the operator that one or more of the engine parameters is not within normal operating range.

“Derate”

The orange “Warning” lamp will be “Flashing”. After the warning, the engine power will be derated. The warning lamp will begin to flash when the derating occurs.

The engine will be derated if the engine exceeds preset operational limits. The engine derate is achieved by restricting the amount of fuel that is available for each injection. The fuel reduction depends on the severity of the fault that has caused the engine derate, typically up to a limit of 50%. This reduction in fuel results in a predetermined reduction in engine power.

“Shutdown”

The orange warning will be “Flashing”. After the warning, the engine power will be derated. The engine will continue at the rpm of the set derate until a shutdown of the engine occurs. After shutdown the red stop lamp will illuminate.

A shutdown of the engine after being triggered is immediate. The engine can be restarted after a shutdown for use in an emergency. However, the cause of the initial shutdown may still exist.

If there is a signal for high coolant temperature, there will be a 2 second delay to verify the condition.

If there is a signal for low oil pressure, there will be a 2 second delay to verify the condition.

For more information or assistance for repairs, consult your Caterpillar dealer.

i07399976

Sensors and Electrical Components

SMCS Code: 1439; 1900; 7400

The illustration within the section shows the typical locations of the sensors and other electrical components on the Industrial engine. Specific engines may appear different due to the application.

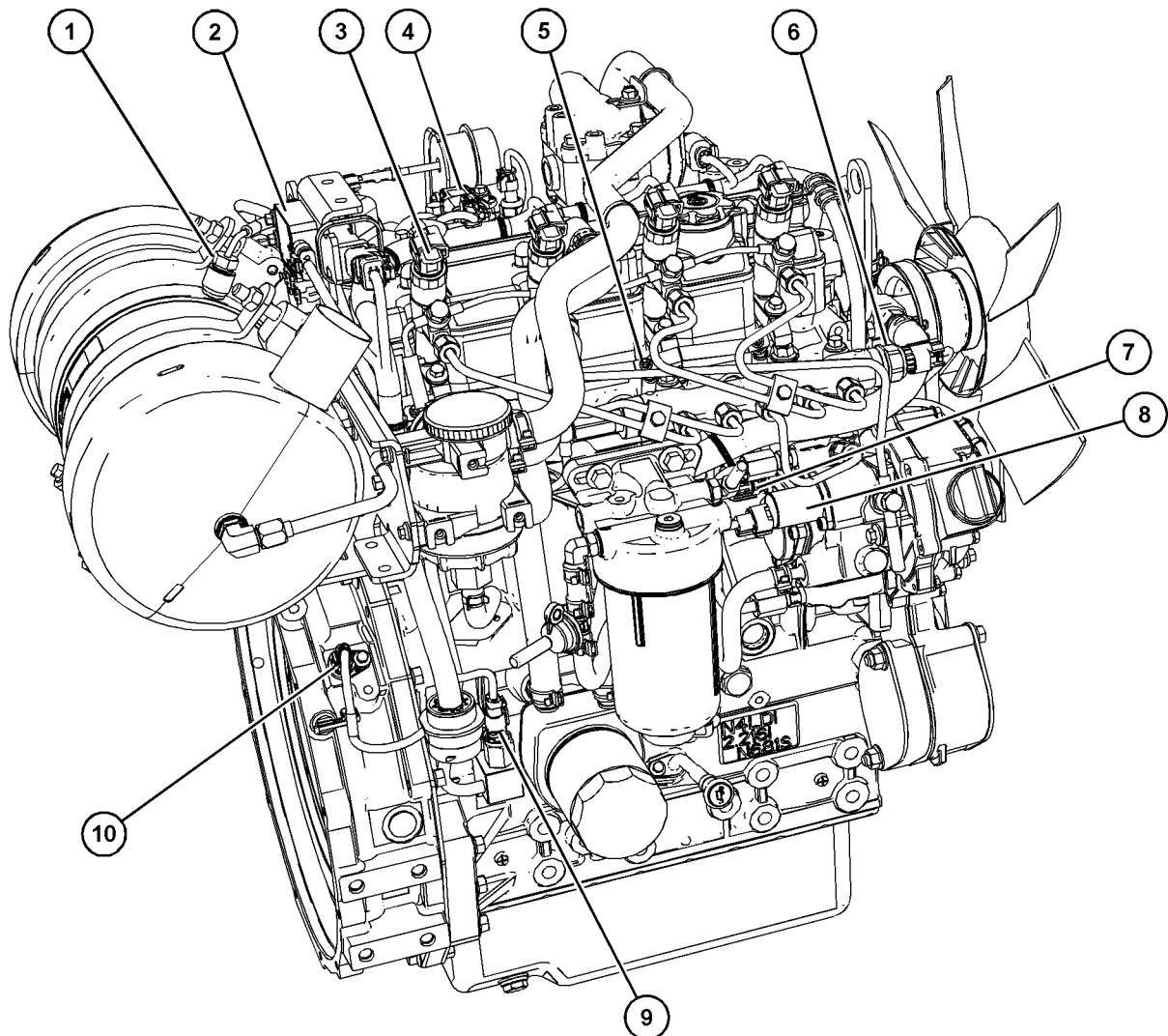

Illustration 43

g06310720

Typical example

- | | | |
|--|--|---|
| (1) Diesel Particulate Filter (DPF) inlet temperature sensor | (5) Glow plug | (8) Suction control valve for the fuel injection pump |
| (2) Differential pressure sensor | (6) Fuel pressure sensor (fuel rail pressure sensor) | (9) Oil pressure switch |
| (3) Electronic unit injector | (7) Fuel temperature Sensor | (10) Crankshaft speed/timing sensor |
| (4) Inlet manifold air temperature sensor | | |

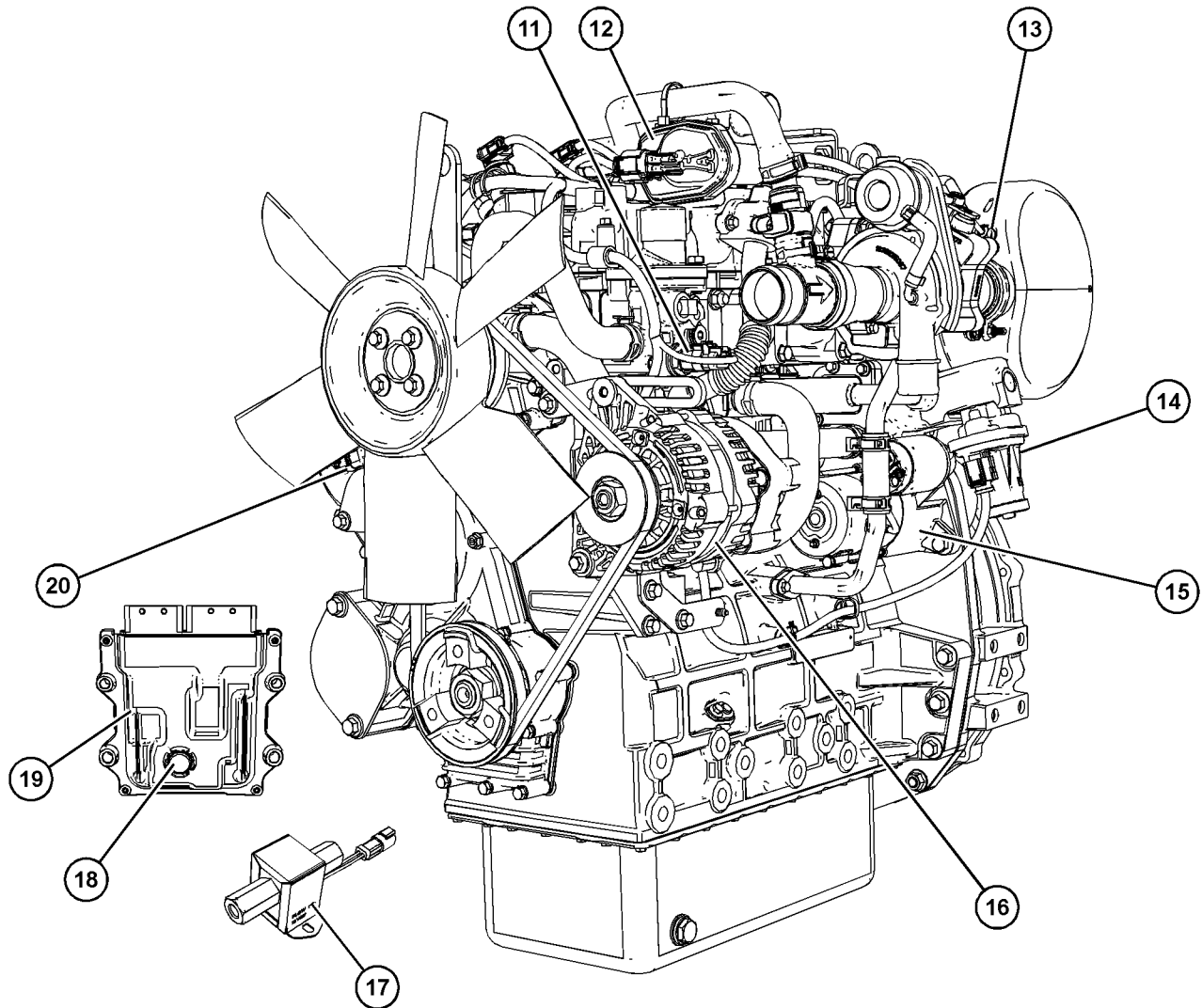

Illustration 44

g06310761

Typical example

- | | | |
|---|---|---|
| (11) Coolant temperature sensor | (14) NOx Reduction System (NRS) control valve | (17) Fuel priming pump |
| (12) Throttle valve | (15) Starting motor | (18) Vent for atmospheric pressure sensor |
| (13) Diesel Oxidation Catalyst (DOC) inlet temperature sensor | (16) Alternator | (19) Electronic Control Module (ECM) |
| | | (20) Camshaft speed/timing sensor |

i09669737

Alarms and Shutoffs**SMCS Code:** 7400**Shutoffs**

The shutoffs are electrically operated or mechanically operated. The electrically operated shutoffs are controlled by the Electronic Control Module (ECM).

Shutoffs are set at critical levels for the following items:

- Coolant operating temperature
- Oil operating pressure

The particular shutoff may need to be reset before the engine will start.

NOTICE

Always determine the cause of the engine shutdown. Make necessary repairs before attempting to restart the engine.

Be familiar with the following items:

- Types and locations of shutoff
- Conditions which cause each shutoff to function
- The resetting procedure that is required to restart the engine

Alarms

NOTICE

When an alarm is activated, corrective measures must be taken before the situation becomes an emergency in order to avoid possible engine damage.

The alarms are electrically operated. The operations of the alarms are controlled by the ECM.

The alarm is operated by a sensor or by a switch. When the sensor or the switch is activated, a signal is sent to the ECM. An event code is created by the ECM. The ECM will send a signal to illuminate the lamp.

Your engine may be equipped with the following sensors or switches:

Fuel rail pressure – The fuel rail pressure sensor measures the high pressure or low pressure in the fuel rail. The ECM will Check the pressure.

Engine oil pressure – The engine oil pressure switch indicates when oil pressure drops below rated system pressure, at a set engine speed.

Coolant temperature – The coolant temperature sensor indicates high jacket water coolant temperature.

i07966623

Overspeed

SMCS Code: 1900; 1907; 1912; 7427

The overspeed threshold is the Revolution Per Minute (RPM) listed below for the engines covered by this Operation and Maintenance Manual.

- C1.7 turbocharged engine_____3700 RPM
- C2.2 turbocharged engine_____3700 RPM
- C2.2 turbocharged engine with charge cooler
_____3700 RPM

Engine Diagnostics

i05142509

Self-Diagnostics

i06542477

SMCS Code: 1000; 1900; 1901; 1902

Caterpillar Electronic Engines can perform a self-diagnostics test. When the system detects an active problem, a diagnostic lamp is activated. Diagnostic codes will be stored in permanent memory in the Electronic Control Module (ECM). The diagnostic codes can be retrieved by using Caterpillar electronic service tools.

Some installations have electronic displays that provide direct readouts of the engine diagnostic codes. Refer to the manual that is provided by the OEM for more information on retrieving engine diagnostic codes.

Active codes represent problems that currently exist. These problems should be investigated first.

Logged codes represent the following items:

- Intermittent problems
- Recorded events
- Performance history

A maximum of 6 codes can be stored at one time.

If 6 codes are already present, then the engine will still react to another fault, but the fault will not be logged by the ECM.

The problems may have been repaired since the logging of the code. These codes do not indicate that a repair is needed. The codes are guides or signals when a situation exists. Codes may be helpful to troubleshoot problems.

When the problems have been corrected, the corresponding logged fault codes should be cleared.

i04053182

Diagnostic Lamp

SMCS Code: 1000; 1900; 1901; 1902; 7451

A diagnostic lamp is used to indicate the existence of an active fault. Refer to Troubleshooting , “Indicator Lamps” for more information. A fault diagnostic code will remain active until the problem is repaired. The diagnostic code may be retrieved by using the electronic service tool. Refer to Troubleshooting , “Electronic Service Tools” for more information.

Fault Logging

SMCS Code: 1000; 1900; 1901; 1902

The system provides the capability of Fault Logging. When the Electronic Control Module (ECM) generates an active diagnostic code, the code will be logged in the memory of the ECM. The codes that have been logged by the ECM can be identified by the electronic service tool. The active codes that have been logged will be cleared when the fault has been rectified or the fault is no longer active.

i06748909

Engine Operation with Active Diagnostic Codes

SMCS Code: 1000; 1900; 1901; 1902

If a diagnostic lamp illuminates during normal engine operation, the system has identified a situation that is not within the specification. Use electronic service tools to check the active diagnostic codes.

Note: The power may be limited until the problem is corrected. If the oil pressure is within the normal range, the engine may be operated at the rated speed and load. However, maintenance should be performed as soon as possible.

The active diagnostic code should be investigated. The cause of the problem should be corrected as soon as possible. If the cause of the active diagnostic code is repaired and there is only one active diagnostic code, the diagnostic lamp will turn off.

Operation of the engine and performance of the engine can be limited as a result of the active diagnostic code that is generated. Acceleration rates may be significantly slower. Refer to the Troubleshooting for more information on the relationship between these active diagnostic codes and engine performance.

i04053849

Engine Operation with Intermittent Diagnostic Codes

SMCS Code: 1000; 1900; 1901; 1902

If a diagnostic lamp illuminates during normal engine operation and the diagnostic lamp shuts off, an intermittent fault may have occurred. If a fault has occurred, the fault will be logged into the memory of the Electronic Control Module (ECM).

In most cases, stopping the engine will not be necessary because of an intermittent code. However, the operator should retrieve the logged fault codes and the operator should reference the appropriate information in order to identify the nature of the event. The operator should log any observation that could have caused the lamp to light.

- Low power
- Limits of the engine speed
- Engine vibration or engine noise

This information can be useful to help troubleshoot the situation. The information can also be used for future reference. For more information on diagnostic codes, refer to the Troubleshooting Guide for this engine.

i05142533

Configuration Parameters

SMCS Code: 1000; 1900; 1901; 1902

System configuration parameters affect the emissions of the engine or the power of the engine. System configuration parameters are programmed at the factory. Normally, system configuration parameters would never change through the life of the engine. System configuration parameters must be reprogrammed if an Electronic Control Module (ECM) is replaced. System configuration parameters are not reprogrammed if the ECM software is changed.

For more information, refer to Troubleshooting, "System Configuration Parameters".

Engine Starting

i07907097

i04053911

Before Starting Engine

SMCS Code: 1000; 1400; 1450

Perform the required daily maintenance and other periodic maintenance before the engine is started. Inspect the engine compartment. This inspection can help prevent major repairs at a later date. Refer to the Operation and Maintenance Manual, "Maintenance Interval Schedule" for more information.

- Ensure that the engine has an adequate fuel supply.
- Open the fuel supply valve (if equipped).

If the engine has not been started for several weeks, fuel may have drained from the fuel system. Air may have entered the filter housing. Also, when fuel filters have been changed, some air pockets will be trapped in the engine. In these instances, prime the fuel system. Refer to the Operation and Maintenance Manual, "Fuel System - Prime" for more information on priming the fuel system. Also, check that the fuel specification is correct and that the fuel condition is correct. Refer to the Operation and Maintenance Manual, "Fuel Recommendations".

WARNING

Engine exhaust contains products of combustion which may be harmful to your health. Always start and operate the engine in a well ventilated area and, if in an enclosed area, vent the exhaust to the outside.

- Do not start the engine or move any of the controls if there is a "DO NOT OPERATE" warning tag or similar warning tag attached to the start switch or to the controls.
- Reset all of the shutoffs or alarm components.
- Ensure that any driven equipment has been disengaged. Minimize electrical loads or remove any electrical loads.

Starting the Engine

SMCS Code: 1000; 1450

WARNING

Do not use aerosol types of starting aids such as ether. Such use could result in an explosion and personal injury.

Note: Do not adjust the engine speed control during start-up. The electronic control module (ECM) will control the engine speed during start-up.

Starting the Engine

1. Disengage any equipment that is driven by the engine.

Note: During key ON, the indicator lamps will be illuminated for 0.5 of a second to check the lamp operation. If any of the indicator lamps do not illuminate check the bulb. If any indicator lamps stay illuminated or flash, refer to Troubleshooting, "Indicator Lamp Circuit - Test".

2. Turn the keyswitch to the RUN position. Leave the keyswitch in the RUN position until the warning light for the glow plugs is extinguished.
3. When the wait to start lamp for the glow plugs has been extinguished turn the keyswitch to the START position. The starter motor will then crank the engine.

Note: The operating period of the wait to start lamp for the glow plugs will change due to the ambient air temperature.

NOTICE

Do not engage the starting motor when flywheel is turning. Do not start the engine under load.

If the engine fails to start within 30 seconds, release the starter switch or button and wait two minutes to allow the starting motor to cool before attempting to start the engine again.

4. Allow the keyswitch to return to the RUN position after the engine starts.
5. Repeat step 2 through step 4 if the engine fails to start.

6. Constant speed engines should be allowed to reach operating speed with no load. Operate engine for 2 minutes before applying load.

i07907357

Cold Weather Starting

SMCS Code: 1000; 1250; 1450; 1453; 1456; 1900

WARNING

Do not use aerosol types of starting aids such as ether. Such use could result in an explosion and personal injury.

The ability to start the engine will be improved at temperatures below -18°C (0°F) or at high altitude above 2000 m (6561 ft) from the use of a jacket water heater or extra battery capacity.

When Group 2 diesel fuel is used, the following items provide a means of minimizing starting problems and fuel problems in cold weather: Engine oil pan heaters, jacket water heaters, fuel heaters, and fuel line insulation.

Use the procedure that follows for cold weather starting.

Note: Do not adjust the engine speed control during start-up. The electronic control module (ECM) will control the engine speed during start-up.

In cold conditions the ECM on turbocharged engines is programmed with an idle hold feature that will prevent the engine from being revved above 800 Revolutions Per Minute (RPM) until the engine reaches the required operating temperature.

1. Disengage any driven equipment.

Note: During key ON, the indicator lamps will be illuminated for 0.5 of a second to check the lamp operation. If any of the indicator lamps do not illuminate, check the bulb. If any indicator lamps stay illuminated or flash, refer to Troubleshooting, "Indicator Lamp Circuit - Test".

2. Turn the keyswitch to the RUN position. Leave the keyswitch in the RUN position until the wait to start lamp for the glow plugs is extinguished.
3. When the wait to start lamp for the glow plugs is extinguished, turn the keyswitch to the START position to engage the electric starting motor and crank the engine.

Note: The operating period of the warning light for the glow plugs will change due to the ambient air temperature.

NOTICE

Do not engage the starting motor when flywheel is turning. Do not start the engine under load.

If the engine fails to start within 30 seconds, release the starter switch or button and wait two minutes to allow the starting motor to cool before attempting to start the engine again.

4. Allow the keyswitch to return to the RUN position after the engine starts.

5. Repeat step 2 through step 4 if the engine fails to start.

Note: The engine should not be "raced" to speed up the warm-up process.

6. Allow the engine to idle for 3 to 5 minutes, or allow the engine to idle until the water temperature indicator begins to rise. When idling after the engine has started in cold weather, increase the engine rpm from 1000 to 1200 rpm. This operation will warm up the engine more quickly. Maintaining an elevated low idle speed for extended periods will be easier with the installation of a hand throttle.
7. Operate the engine at low load until all systems reach operating temperature. Check the gauges during the warm-up period.
8. Constant speed engines could be allowed to reach operating speed with no load. Operate the engine for 2 minutes before applying load.

i07907104

Starting with Jump Start Cables

(Do Not Use This Procedure in Hazardous Locations that have Explosive Atmospheres)

SMCS Code: 1000; 1401; 1402; 1900

WARNING

The connection of battery cables to a battery and the disconnection of battery cables from a battery may cause an explosion which may result in injury or death. The connection and the disconnection of other electrical equipment may also cause an explosion which may result in injury or death. The procedures for the connection and the disconnection of battery cables and other electrical equipment should only be performed in a nonexplosive atmosphere.

⚠ WARNING

Improper jump start cable connections can cause an explosion resulting in personal injury.

Prevent sparks near the batteries. Sparks could cause vapors to explode. Do not allow jump start cable ends to contact each other or the engine.

Note: If possible, first diagnose the reason for the starting failure. Refer to Troubleshooting, “Engine Will Not Crank and Engine Cranks But Will Not Start” for further information. Make any necessary repairs. If the engine will not start only due to the condition of the battery, either charge the battery, or start the engine by using another battery with jump-start cables. The condition of the battery can be rechecked after the engine has been switched OFF.

NOTICE

Ensure that a 12 VDC battery source is used to start the engine. Never attempt to start an engine from an external power source such as electric welding equipment, which has a voltage that is unsuitable for engine starting and will damage the electrical system.

NOTICE

Using a battery source with the same voltage as the electric starting motor. Use **ONLY** equal voltage for jump starting. The use of higher voltage will damage the electrical system.

Do not reverse the battery cables. The alternator can be damaged. Attach ground cable last and remove first.

Turn all electrical accessories OFF before attaching the jump start cables.

Ensure that the main power switch is in the OFF position before attaching the jump start cables to the engine being started.

1. Turn the start switch on the stalled engine to the OFF position. Turn off all the engines accessories.
2. Connect one positive end of the jump-start cable to the positive cable terminal of the discharged battery. Connect the other positive end of the jump-start cable to the positive cable terminal of the electrical source.
3. Connect one negative end of the jump-start cable to the negative cable terminal of the electrical source. Connect the other negative end of the jump-start cable to the engine block or to the chassis ground. This procedure helps to prevent potential sparks from igniting the combustible gases that are produced by some batteries.

Note: The engine ECM must be powered before the starting motor is operated or damage can occur.

4. Start the engine in the normal operating procedure. Refer to this Operation and Maintenance Manual, “Starting the Engine”.
5. Immediately after the engine is started, disconnect the jump-start cables in reverse order.

After jump starting, the alternator may not be able to recharge fully batteries that are severely discharged. The batteries must be replaced or charged to the proper voltage with a battery charger after the engine is stopped. Many batteries which are considered unusable are still rechargeable. Refer to Operation and Maintenance Manual, “Battery - Replace” and Testing and Adjusting Manual, “Battery - Test”.

i07818134

After Starting Engine

SMCS Code: 1000

After starting, the engine may be held at low speed for up to 30 seconds to allow engine systems to stabilize. The duration will depend on ambient temperature, time since last run and other factors.

After starting the engine and allowing the engine to stabilize, increase the engine speed to 1500 RPM for 10 seconds to ensure that the alternator begins to charge the battery.

Note: In ambient temperatures from 0° to 48°C (0° to 86.4°F), the warm-up time is approximately 3 minutes. In temperatures below 0°C (32°F), additional warm-up time may be required.

When the engine idles during warm-up, observe the following conditions:

Do not check the high-pressure fuel lines with the engine or the starting motor in operation. If you inspect the engine in operation, always use the proper inspection procedure to avoid a fluid penetration hazard. Refer to Operation and Maintenance Manual, “General Hazard Information” for more information.

- Check for fluid and air leaks at idle rpm, and at one-half full rpm (no load on the engine) before operating the engine under load. This check may not be possible in some applications.
- Allow the engine to idle for 3 to 5 minutes, or allow the engine to idle until the water temperature indicator begins to rise. Check all gauges during the warm-up period.

Operation Section
After Starting Engine

Constant speed engines should be allowed to operate at low idle for 3 minutes before used at operational speed. If the low idle option is not available, then operate the engine at operational speed with no load for 2 minutes.

Note: Gauge readings should be observed and the data should be recorded frequently whilst the engine is operating. Comparing the data over time will help to determine normal readings for each gauge. Comparing data over time will also help detect abnormal operating developments. Significant changes in the readings should be investigated.

Engine Operation

i07398996

Engine Operation

SMCS Code: 1000

Correct operation and maintenance are key factors in obtaining the maximum life and economy of the engine. If the directions in the Operation and Maintenance Manual are followed, costs can be minimized and engine service life can be maximized.

Variable Speed Engine

The engine can be operated at the rated rpm after the engine reaches operating temperature. The engine will reach normal operating temperature sooner during a low engine speed (rpm) and during a low-power demand. This procedure is more effective than idling the engine at no load. The engine should reach operating temperature in a few minutes.

Gauge readings should be observed and the data should be recorded frequently while the engine is operating. Comparing the data over time will help to determine normal readings for each gauge. Comparing data over time will also help detect abnormal operating developments. Significant changes in the readings should be investigated.

Constant Speed Engine

Allow the engine to warm up before applying load.

Gauge readings should be observed and the data should be recorded frequently while the engine is operating. Comparing the data over time will help to determine normal readings for each gauge. Comparing data over time will also help detect abnormal operating developments. Significant changes in the readings should be investigated.

Reduction of Particulate Emissions

The engine is equipped with an aftertreatment system to meet emissions regulations. The system uses a Diesel Oxidation Catalyst (DOC) and Diesel Particulate Filter (DPF) to meet emissions regulations. The DOC and DPF do not require a service interval to operate correctly.

i10233660

Engine Operation

SMCS Code: 1000

Correct operation and maintenance are key factors in obtaining the maximum life and economy of the engine. If the directions in the Operation and Maintenance Manual are followed, costs can be minimized and engine service life can be maximized.

The time that is needed for the engine to reach normal operating temperature is only a few minutes.

The engine can be operated at the rated rpm after the engine is started and after the engine reaches operating temperature. The engine will reach normal operating temperature sooner during a low engine speed (rpm) and during a low-power demand. This procedure is more effective than idling the engine at no load. The engine should reach operating temperature in a few minutes.

Avoid excess idling or excess low load operation. Excessive idling or excessive low load operation can cause:

- Carbon build-up
- Increased oil consumption - Higher than expected oil consumption
- Engine slobber ('wetstacking') - Exhaust manifold "slobber" (black oily substance found leaking from exhaust manifold joints)
- Loss of performance
- Harmful deposits in the aftertreatment system (if equipped) - Emissions Aftertreatment systems may lose efficiency or malfunction

These issues are harmful to the engine.

Caterpillar recommends a minimum load factor of 30% over any 8-hour period of engine operation. Within this period load should be maintained at >30% for at least 20 continuous minutes, which may help in avoiding any engine operation issues. Caterpillar also recommends limiting periods of low idle running to avoid engine operation issues.

Gauge readings should be observed and the data should be recorded frequently while the engine is operating. Comparing the data over time will help to determine normal readings for each gauge.

Comparing data over time will also help detect abnormal operating developments. Significant changes in the readings should be investigated.

Engine Operation and the Aftertreatment System

The exhaust gases and hydrocarbon particles from the engine first pass through Diesel Oxidation Catalyst (DOC). Some of the gasses and matter are oxidized as the gasses pass through the DOC. The gasses then pass through the Diesel Particulate Filter (DPF). The DPF collects the soot and any ash that is produced by the combustion in the engine. During regeneration, the soot is converted into a gas and the ash remains in the DPF.

The DPF may require the exhaust gas temperature to rise to remove the soot. If necessary, the throttle valve is operated to help in rising the exhaust temperature.

This design of DPF will not require a service maintenance interval. The DPF can be expected to function properly for the useful life of the engine (emissions durability period), as defined by regulation, subject to prescribed maintenance requirements being followed.

A fault code will be active for any DPF system-related issue. Follow the troubleshooting guide to rectify the issue.

If the DPF loses function, or is tampered with in any way, the check engine lamp, and an amber action (if equipped) will illuminate. A fault code will also annunciate. The lamps and fault code will remain active until the problem is rectified.

NOTICE

The engine and emissions control system shall be operated, used, and maintained in accordance with the instructions provided. Failure to follow the instructions could result in emissions performance that does not meet the requirements applicable to the category of the engine. No deliberate tampering with, or misuse of the engine emissions control system should take place. Prompt action is critical to rectify any incorrect operation, use, or maintenance of the emissions control system.

Carbon Dioxide (CO₂) Emissions Statement

European Union (EU) Stage V emissions regulations require that the value of the CO₂ emissions be reported to the end user. The CO₂ values are reported for each emissions family, this was determined during the EU type approval process for the parent engine. This CO₂ measurement results from testing over a fixed test cycle under laboratory conditions of a(n) (parent) engine representative of the engine type (engine family) and shall not imply or express any guarantee of the performance of a particular engine.

Table 4

Engine Commercial Name	EU Emissions Family	Emissions Family CO ₂ Value (g/kWh)
C1.7	NRE2V2.22HPB	887.57
C2.2	NRE2V2.22HPB	887.57
C2.2	NRE2V1.22HPA	805.0214

i01646335

Engaging the Driven Equipment

SMCS Code: 1000

1. Operate the engine at one-half of the rated rpm, when possible.
2. Engage the driven equipment without a load on the equipment, when possible.

Interrupted starts put excessive stress on the drive train. Interrupted starts also waste fuel. To get the driven equipment in motion, engage the clutch smoothly with no load on the equipment. This method should produce a start that is smooth and easy. The engine rpm should not increase and the clutch should not slip.

3. Ensure that the ranges of the gauges are normal when the engine is operating at one-half of the rated rpm. Ensure that all gauges operate properly.
4. Increase the engine rpm to the rated rpm. Always increase the engine rpm to the rated rpm before the load is applied.
5. Apply the load. Begin operating the engine at low load. Check the gauges and equipment for proper operation. After normal oil pressure is reached and the temperature gauge begins to move, the engine may be operated at full load. Check the gauges and equipment frequently when the engine is operated under load.

Extended operation at low idle or at reduced load may cause increased oil consumption and carbon buildup in the cylinders. This carbon buildup results in a loss of power and/or poor performance.

- Ensure that the belts are correctly adjusted. The belts should be in good condition. Refer to the Specifications manual for further information.
- Ensure that all the connections of the hoses are tight. The connections should not leak.
- Ensure that the driven equipment is in good working order.
- Cold engines consume excess fuel. Utilize heat from the jacket water system and the exhaust system, when possible. Keep cooling system components clean and keep cooling system components in good repair. Never operate the engine without water temperature regulators. All these items will help maintain operating temperatures.

i07818141

Fuel Conservation Practices

SMCS Code: 1000; 1250

The efficiency of the engine can affect the fuel economy. The design and technology in manufacturing provides maximum fuel efficiency in all applications. Always ensure that genuine filters are used. Follow the recommended procedures to attain optimum performance for the life of the engine.

- Avoid spilling fuel.

Fuel expands when the fuel is warmed up. The fuel may overflow from the fuel tank. Inspect fuel lines for leaks. Repair the fuel lines, as needed.

- Be aware of the properties of the different fuels. Use only the recommended fuels. Refer to the Operations and Maintenance Manual, "Fuel Recommendations" for further information.
- Avoid unnecessary idling.
- Shut off the engine rather than idle for long periods of time.
- Observe the service indicator frequently. Keep the air cleaner elements clean.
- Ensure that the turbocharger is operating correctly so that the proper air/fuel ratio is maintained. Clean exhaust indicates proper functioning.
- Maintain a good electrical system.

One faulty battery cell will overwork the alternator and can consume excess power and excess fuel.

Engine Stopping

i06832774

Stopping the Engine

SMCS Code: 1000; 7000

NOTICE

Stopping the engine immediately after it has been working under load, can result in overheating and accelerated wear of the engine components.

Avoid accelerating the engine prior to shutting it down.

Avoiding hot engine shutdowns will maximize turbo-charger shaft and bearing life.

Note: Individual applications will have different control systems. Ensure that the shutoff procedures are understood. Use the following general guidelines to stop the engine.

1. Remove the load from the engine. Reduce the engine speed (rpm) to low idle. Allow the engine to idle for 5 minutes to cool the engine.
2. Stop the engine after the cool down period according to the shutoff system on the engine. Turn the ignition key switch to the OFF position. If necessary, refer to the instructions that are provided by the OEM.

NOTICE

Before any service or repairs are performed, ensure that the power supply to the engine is disconnected.

i03554860

Emergency Stopping

SMCS Code: 1000; 7418

NOTICE

Emergency shutoff controls are for EMERGENCY use ONLY. DO NOT use emergency shutoff devices or controls for normal stopping procedure.

Ensure that any components for the external system that support the engine operation are secured after the engine is stopped.

Emergency Stop Button

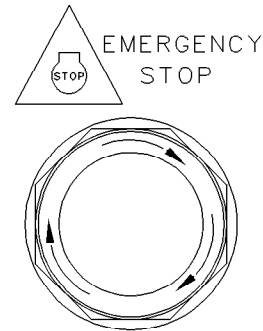

Illustration 45

g00104303

Typical emergency stop button

The emergency stop button is in the OUT position for normal engine operation. Push the emergency stop button. The engine will not start when the button is locked. Turn the button clockwise in order to reset.

Refer to Operation and Maintenance Manual, "Features and Controls" for the location and the operation of the emergency stop button.

i03756631

After Stopping Engine

SMCS Code: 1000

Note: Before you check the engine oil, do not operate the engine for at least 10 minutes in order to allow the engine oil to return to the oil pan.

- Check the crankcase oil level. Maintain the oil level between the "MIN" mark and the "MAX" mark on the engine oil level gauge.
- If necessary, perform minor adjustments. Repair any leaks and tighten any loose bolts.
- If the engine is equipped with a service hour meter, note the reading. Perform the maintenance that is in the Operation and Maintenance Manual, "Maintenance Interval Schedule".
- Fill the fuel tank in order to help prevent accumulation of moisture in the fuel. Do not overfill the fuel tank.

NOTICE

Only use antifreeze/coolant mixtures recommended in the Refill Capacities and Recommendations topic that is in this Operation and Maintenance Manual. Failure to do so can cause engine damage.

- Allow the engine to cool. Check the coolant level.

- If freezing temperatures are expected, check the coolant for correct antifreeze protection. The cooling system must be protected against freezing to the lowest expected outside temperature. Add the correct coolant/water mixture, if necessary.
- Perform all required periodic maintenance on all driven equipment. This maintenance is outlined in the instructions from the OEM.

Cold Weather Operation

i07967054

Cold Weather Operation

SMCS Code: 1000; 1250

Caterpillar Diesel Engines can operate effectively in cold weather. During cold weather, the starting and the operation of the diesel engine depends the following items:

- The type of fuel that is used
- The viscosity of the engine oil
- The operation of the glow plugs
- Optional Cold starting aid
- Battery condition
- Ambient air temperature and altitude
- Parasitic load of the application
- Application hydraulic and transmission oil viscosities

This section will cover the following information:

- Potential problems that are caused by cold-weather operation
- Suggest steps which can be taken to minimize starting problems and operating problems when the ambient air temperature is between 0° to -40 °C (32° to 40 °F).

The operation and maintenance of an engine in freezing temperatures is complex. This complexity is because of the following conditions:

- Weather conditions
- Engine applications

Recommendations from your Caterpillar dealer are based on past proven practices. The information that is contained in this section provides guidelines for cold-weather operation.

Hints for Cold-Weather Operation

- After starting the engine, the engine speed will be governed for up to a maximum of 30 seconds. After this period, the engine should be operated at low loads until a minimum coolant operating temperature of 80° C (176° F) is achieved.
- Achieving operating temperature will help prevent the intake valves and exhaust valves from sticking.

- The cooling system and the lubrication system for the engine do not lose heat immediately upon shutdown. This means that an engine can be shut down for a period and the retained heat within the engine will allow the engine readily start.
- Install the correct specification of engine lubricant before the beginning of cold weather. Refer to this Operation and Maintenance Manual, "Fluid Recommendations" for the recommended viscosity of oil.
- Check all rubber parts (hoses, fan drive belts) weekly.
- Check all electrical wiring and connections for any fraying or damaged insulation.
- Keep all batteries fully charged and warm by ensuring that the engine is allowed correct operation at normal operating temperature.
- Fill the fuel tank at the end of each shift.
- Check the air cleaners and the air intake daily. Check the air intake more often when you operate in snow.
- Ensure that the glow plugs are in working order. Refer to Troubleshooting, "Glow Plug Starting Aid-Test".

WARNING

Personal injury or property damage can result from alcohol or starting fluids.

Alcohol or starting fluids are highly flammable and toxic and if improperly stored could result in injury or property damage.

WARNING

Do not use aerosol types of starting aids such as ether. Such use could result in an explosion and personal injury.

- For jump starting with cables in cold weather, refer to the Operation and Maintenance Manual, "Starting with Jump-Start Cables." for instructions.

Viscosity of the Engine Lubrication Oil

Correct engine oil viscosity is essential. Oil viscosity affects lubrication properties and the wear protection that the oil provides for the engine. Refer to this Operation and Maintenance Manual, "Fluid Recommendations" for the recommended viscosity of oil.

At temperatures below -10°C (14°F) damage to engine components can occur if the engine is allowed to operate at high load and speed immediately after starting.

Recommendations for the Coolant

Provide cooling system protection for the lowest expected outside temperature. Refer to this Operation and Maintenance Manual, "Fluid Recommendations" for the recommended coolant mixture.

In cold weather, check the coolant often for the correct glycol concentration to ensure adequate freeze protection.

Engine Block Heaters

Engine block heaters (if equipped) heat the engine jacket water that surrounds the combustion chambers. This heat provides the following functions:

- Starting ability is improved.
- Warm up time is reduced.

An electric block heater can be activated once the engine is stopped. A block heater can be 110 V DC or 240 V DC. The output can be 600/1000W. Consult your Caterpillar dealer for more information.

Idling the Engine

After starting the engine, the engine speed will be governed for a maximum period of 30 seconds. When idling after the engine is started in cold weather, increase the engine rpm from 1000 rpm to 1200 rpm. This idling will warm up the engine more quickly. Maintaining an elevated low idle speed for extended periods will be easier with the installation of a hand throttle. The engine should not be "raced" to speed up the warm up process.

Whilst the engine is idling, the application of a light load (parasitic load) will help in achieving the minimum operating temperature. The minimum coolant operating temperature is 80°C (176°F).

Recommendations for Coolant Warm Up

Warm up an engine that has cooled below normal operating temperatures due to inactivity. This warm up should be performed before the engine is returned to full operation. During operation in very cold temperature conditions, damage to engine valve mechanisms can result from engine operation for short intervals. This damage can happen if the engine is started and the engine is stopped many times without being operated to warm up completely.

When the engine is operated below normal operating temperatures, fuel and oil are not burned completely in the combustion chamber. This fuel and oil causes soft carbon deposits to form on the valve stems. Generally, the deposits do not cause problems and the deposits are burned off during operation at normal engine operating temperatures.

When starting and stopping an engine many times without being operated to warm up completely, the carbon deposits become thicker. This starting and stopping can cause the following problems:

- Free operation of the valves is prevented.
- Valves become stuck.
- Pushrods may become bent.
- Other damage to valve train components can result.

For these reasons, when the engine is started, the engine must be operated until the coolant temperature is 80°C (176°F) minimum. Carbon deposits on the valve stem will be kept at a minimum. The free operation of the valves and the valve components will be maintained.

The engine must be warmed thoroughly to keep other engine parts in better condition. The service life of the engine will generally be extended. Lubrication will be improved. There will be less acid and less sludge in the oil. This condition will provide longer service life for the engine bearings, the piston rings, and other parts. However, limit unnecessary idle time to 10 minutes to reduce wear and unnecessary fuel consumption.

The Water Temperature Regulator and Insulated Heater Lines

The engine is equipped with a water temperature regulator. When the engine coolant is below the correct operating temperature, jacket water circulates through the engine cylinder block and into the engine cylinder head. The coolant then returns to the cylinder block via an internal passage that bypasses the valve of the coolant temperature regulator. This return ensures that coolant flows around the engine under cold operating conditions. The water temperature regulator begins to open when the engine jacket water has reached the correct minimum operating temperature. As the jacket water coolant temperature rises above the minimum operating temperature, the water temperature regulator opens further allowing more coolant through the radiator to dissipate excess heat.

The progressive opening of the water temperature regulator operates the progressive closing of the bypass passage between the cylinder block and head. This action ensures maximum coolant flow to the radiator to achieve maximum heat dissipation.

Note: Do not restrict the air flow. Restriction of the air flow can damage the fuel system. Caterpillar discourages the use of all air flow restriction devices such as radiator shutters. Restriction of the air flow can result in the following: high exhaust temperatures, power loss, excessive fan usage, and reduction in fuel economy.

A cab heater is beneficial in cold weather. The feed from the engine and the return lines from the cab should be insulated to reduce heat loss to the outside air.

Recommendation for Crankcase Breather Protection

Crankcase ventilation gases contain a large quantity of water vapor. This water vapor can freeze in cold ambient conditions and can plug or damage the crankcase ventilation system. If the engine is operated in temperatures of -25°C (-13°F) or lower, measures must be taken to prevent freezing and plugging of the breather system. Insulated hoses and an insulated canister assembly should be installed. A heater unit must also be installed into the breather system. Both measures are required to protect the engine when working in temperatures of -25°C (-13°F) or lower.

i07979625

Fuel and the Effect from Cold Weather

SMCS Code: 1000; 1250

Note: Only use grades of fuel that are recommended by Caterpillar. Refer to this Operation and Maintenance Manual, "Fluid Recommendations".

Properties of the diesel fuel can have a significant effect on the engine cold start capability. It is critical that the low temperature properties of diesel fuel are acceptable for the minimum ambient temperature the engine is expected to see in operation.

Following properties are used to define fuels low temperature capability:

- Cloud point
- Pour point
- Cold Filter Plugging Point (CFPP)

The cloud point of the fuel is the temperature at which waxes naturally found in the diesel fuel begin to form crystals. The cloud point of the fuel must be below lowest ambient temperature to prevent filters from plugging.

Pour point is the last temperature before the fuel flow stops and waxing of the fuel will start.

Cold Filter Plugging Point (CFPP) is a temperature at which a particular fuel will pass through a standardized filtration device. This CFPP gives an estimate of the lower operability temperature of fuel

Be aware of these properties when diesel fuel is purchased. Consider the average ambient air temperature for the engines application. Engines that are fueled in one climate may not operate well if the engines are shipped to colder climate. Problems can result due to changes in temperature.

Before troubleshooting for low power or for poor performance in the winter, check the fuel for waxing

The following components can provide a means of minimizing fuel waxing problems in cold weather:

- Fuel heaters, which may be an OEM option
- Fuel line insulation, which may be an OEM option

Winter and arctic grades of diesel fuel are available in the countries and territories with severe winters. For more information refer to the Operation and Maintenance Manual, "Fuel For Cold-Weather Operation"

Another important fuel property which can affect cold start and operation of diesel engine is Cetane number. Detail and requirements of this property are given in this Operation and Maintenance Manual, "Fluid Recommendations".

i05359588

Fuel Related Components in Cold Weather

SMCS Code: 1000; 1250

Fuel Tanks

Condensation can form in partially filled fuel tanks. Top off the fuel tanks after you operate the engine.

Fuel tanks should contain some provision for draining water and sediment from the bottom of the tanks.

Some fuel tanks use supply pipes that allow water and sediment to settle below the end of the fuel supply pipe.

Some fuel tanks use supply lines that take fuel directly from the bottom of the tank. If the engine is equipped with this system, regular maintenance of the fuel system filter is important.

Drain the water and sediment from any fuel storage tank at the following intervals: weekly, service intervals and refueling of the fuel tank. Draining will help prevent water and/or sediment from being pumped from the fuel storage tank and into the engine fuel tank.

Fuel Filters

After you change the fuel filter, always prime the fuel system in order to remove air bubbles from the fuel system. Refer to the Operation and Maintenance Manual in the Maintenance Section for more information on priming the fuel system.

The micron rating and the location of a primary fuel filter is important in cold-weather operation. The In-line filter, primary fuel filter, and the fuel supply line are the most common components that are affected by cold fuel.

Fuel Heaters

Note: The OEM may equip the application with fuel heaters. If so, the temperature of the fuel must not exceed 73 °C (163 °F) at the fuel transfer pump. The fuel heater should be installed before the electric lift pump.

For more information about fuel heaters (if equipped), refer to the OEM information.

Maintenance Section

Refill Capacities

i10061490

Refill Capacities

SMCS Code: 1348; 1395; 7560

Engine Oil Refill Capacities

The refill capacities for the engine crankcase reflect the approximate capacity of the crankcase or sump plus standard oil filters. Auxiliary oil filter systems will require more oil. Refer to the OEM specifications for the capacity of the auxiliary oil filter. Refer to the Operation and Maintenance Manual, "Maintenance Section" for more information on Lubricant Specifications.

Table 5

C1.7 Engine Refill Capacities		
Compartment or System	Minimum	Maximum
Crankcase Oil Sump ⁽¹⁾	4.8 L (1.27 US gal)	6.3 L (1.66 US gal)
Total Lubrication System ⁽²⁾		

- (1) More than one style of sump may be used on these engines. Use these values to estimate the refill capacity. Use the engine oil level gauge to fill the engine to the correct oil level. Record the result in this table. These values are the approximate capacities for the Crankcase Oil Sump which includes the standard factory installed oil filters. Engines with auxiliary oil filters will require more oil. Refer to the OEM specifications for the capacity of the auxiliary oil filter.
- (2) The Total Lubrication System includes the capacity for the Crankcase Oil Sump plus the capacity of factory installed oil filters and other filters added to the lubrication system. Enter the value for the capacity of the Total Lubrication System in this row.

Table 6

C2.2 Turbocharged and Turbocharged Aftercooled Engines Refill Capacities		
Compartment or System	Minimum	Maximum
Crankcase Oil Sump ⁽¹⁾	7.2 L (1.90 US gal)	8.5 L (2.25 US gal)
Total Lubrication System ⁽²⁾		

(continued)

(Table 6, contd)

- (1) More than one style of sump may be used on these engines. Use these values to estimate the refill capacity. Use the engine oil level gauge to fill the engine to the correct oil level. Record the result in this table. These values are the approximate capacities for the Crankcase Oil Sump which includes the standard factory installed oil filters. Engines with auxiliary oil filters will require more oil. Refer to the OEM specifications for the capacity of the auxiliary oil filter.
- (2) The Total Lubrication System includes the capacity for the Crankcase Oil Sump plus the capacity of factory installed oil filters and other filters added to the lubrication system. Enter the value for the capacity of the Total Lubrication System in this row.

Coolant Capacities

To maintain the cooling system, the Total Cooling System capacity must be known. The approximate capacity is for the engine cooling system. External System capacities will vary among applications. Refer to the OEM specifications for the External System capacity. This capacity information will be needed to determine the amount of coolant that is required for the Total Cooling System.

Table 7

C1.7 Engine Refill Capacities		
Compartment or System	Liters	US gallons
Engine Only	3.7	0.98
Total Cooling System ⁽¹⁾		

- (1) The External System includes a radiator or an expansion tank with the following components: heat exchanger and piping. Refer to the OEM specifications. Enter the value for the capacity of the External System in this row.

Table 8

C2.2 Turbocharged Engines Refill Capacities		
Compartment or System	Liters	US gallons
Engine Only	4.5	1.19
Total Cooling System ⁽¹⁾		

- (1) The External System includes a radiator or an expansion tank with the following components: heat exchanger and piping. Refer to the OEM specifications. Enter the value for the capacity of the External System in this row.

Table 9

C2.2 Turbocharged Aftercooled Engines Refill Capacities		
Compartment or System	Liters	US gallons
Engine Only	4.5	1.19
Total Cooling System ⁽¹⁾		

- (1) The External System includes a radiator or an expansion tank with the following components: heat exchanger and piping. Refer to the OEM specifications. Enter the value for the capacity of the External System in this row.

Coolant Capacity for Open Power Unit (OPU)

Table 10

3 Cylinder OPU Refill Capacities		
Compartment or System	Liters	US gallons
Engine Only	3.7	0.98
Radiator	4.2	1.11
Total Cooling System	7.9	2.09

Table 11

4 Cylinder Turbocharged OPU Refill Capacities		
Compartment or System	Liters	US gallons
Engine Only	4.5	1.19
Radiator	4.2	1.11
Total Cooling System	8.7	2.30

Table 12

4 Cylinder Turbocharged Aftercooled OPU Refill Capacities		
Compartment or System	Liters	US gallons
Engine Only	4.5	1.19
Radiator	3.7	0.98
Total Cooling System	8.2	2.17

i06510452

Fluid Recommendations

SMCS Code: 1280; 1348; 1395; 7560

Fluid Recommendations

NOTICE

These recommendations are subject to change without notice. Contact your local Cat dealer for the most up-to-date fluids recommendations.

Oil Recommendations

- EMA _____ Engine Manufacturers Association
- API _____ American Petroleum Institute
- SAE _____ Society Of Automotive Engineers Inc.
- DEO-ULS _____ Diesel Engine Oil-Ultra Low Sulfur

Cat DEO-ULS

Cat DEO-ULS is developed and tested to provide superior protection and life for your Caterpillar engines.

- Better Detergents
- Advanced Additive Package
- Enhanced Dispersants
- Improved Protection from Thermal breakdown and Oxidation Breakdown

Due to significant variations in the quality and in the performance of commercially available oils, Caterpillar makes the following recommendations:

- **Cat DEO-ULS (SAE 10W-30)**
- **Cat DEO-ULS (SAE 15W-40)**

Cat DEO-ULS Multigrade oil is available in various viscosity grades that include SAE 10W-30 and SAE 15W-40. To choose the correct viscosity grade for the ambient temperature, see illustration 46 . Multigrade oils provide the correct viscosity for a broad range of operating temperatures. Multigrade oils are also effective in maintaining low oil consumption and low levels of piston deposits.

Consult your Cat dealer for part numbers and for available sizes of containers.

Note: Cat DEO-ULS in SAE 15W-40 passes the following proprietary tests: sticking of the piston ring, oil control tests, wear tests, and soot tests. Proprietary tests help ensure that Caterpillar multigrade oil provides superior performance in Caterpillar Diesel Engines. In addition, Cat DEO-ULS Multigrade oil exceeds many of the performance requirements of other manufacturers of diesel engines. Therefore, this oil is an excellent choice for many mixed fleets. **True high performance oil is produced with a combination of the following factors: industry standard tests, proprietary tests, field tests, and prior experience with similar formulations. The design and the development of Caterpillar lubricants that are both high performance and high quality are based on these factors.**

For more information on oil specification refer to Special Publication, SEBU6251, "Caterpillar Commercial Diesel Engine Fluids Recommendations".

Lubricant Viscosity Recommendations

The proper SAE viscosity grade of oil is determined by the minimum ambient temperature during cold engine start-up, and the maximum ambient temperature during engine operation.

Maintenance Section Fluid Recommendations

Refer to illustration 46 (minimum temperature) to determine the required oil viscosity for starting a cold engine.

Refer to illustration 46 (maximum temperature) to select the oil viscosity for engine operation at the highest ambient temperature that is anticipated.

Note: Generally, use the highest oil viscosity that is available to meet the requirement for the temperature at start-up.

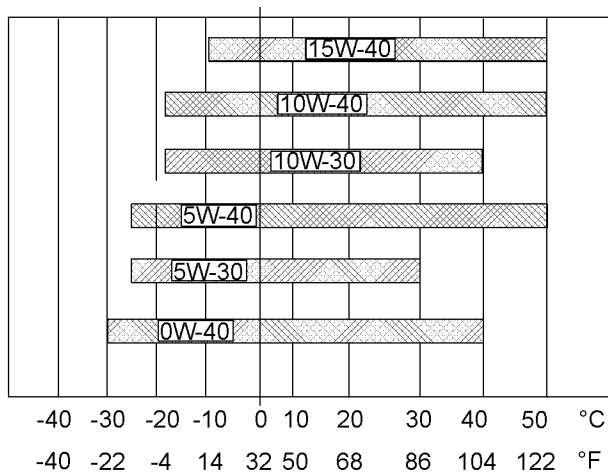

Illustration 46

g03332112

Supplemental heat is recommended for cold soaked starts below the minimum ambient temperature. Supplemental heat may be required for cold soaked starts that are above the minimum temperature that is stated, depending on the parasitic load and other factors. Cold soaked starts occur when the engine has not been operated for a period of time. The cold will allow the oil to become more viscous due to cooler ambient temperatures.

S·O·S Oil Analysis

Caterpillar has developed a tool for maintenance management that evaluates oil degradation and the tool also detects the early signs of wear on internal components. The Caterpillar tool for oil analysis is called S·O·S Oil Analysis and the tool is part of the S·O·S Services program. S·O·S Oil Analysis divides oil analysis into three categories:

- Wear Analysis
- Oil condition
- Additional tests

The wear analysis monitors metal particles, some oil additives, and some contaminants.

Oil condition uses infrared (IR) analysis to evaluate the chemistry of the oil. Infrared analysis is also used to detect certain types of contamination.

Additional tests are used to measure contamination levels from water, fuel, or coolant. Oil viscosity and corrosion protection can be evaluated, as needed.

Refer to Special Publication, SEBU6251, "Caterpillar Commercial Diesel Engine Fluids Recommendations" or contact your local Cat dealer for additional information concerning the S·O·S Oil Analysis program.

Lubricating Grease

Caterpillar provides a range of moderate greases to high performance greases to service the entire line of Caterpillar products that operate throughout the wide variety of climates. You will always be able to find a grease that will meet your machines requirements for a certain application. Caterpillar grease products often exceed Caterpillar specifications.

Before selecting a grease products for any application, the performance requirements must be determined. Consult the grease recommendations that are made by the OEM for the equipment when the equipment is operated in the expected conditions. Then, consult with your Cat dealer for a list of greases and the following related characteristics.

- Performance specifications
- Available sizes of containers
- Part numbers

Always choose a grease that meets the recommendations that are specified by the equipment manufacturer for the application, or choose a grease that exceeds the recommendations that are specified by the equipment manufacturer for the application.

If it is necessary to choose a single grease for use on all the equipment at one site, always choose a grease that meets the requirements of the most demanding application. A product that barely meets the minimum performance requirements will shorten the life of the part. Use the grease that yields the least total operating cost. Base this cost on an analysis that includes the costs of the parts, the labor, the downtime, and the cost of the grease that is used.

Some greases are not chemically compatible. Consult your supplier to determine if two or more greases are compatible.

Purge the grease from a joint at the following times:

- Switching from one grease to another grease
- Switching from one supplier to another supplier

Note: All Caterpillar brand name greases are compatible with each other.

Note: Refer to Special Publication, SEBU6251, "Caterpillar Commercial Diesel Engine Fluids Recommendations" for additional information that relates to lubrication for your engine.

Fuel Recommendations

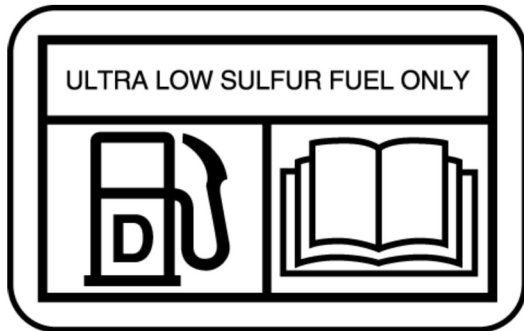

Illustration 47

g02157153

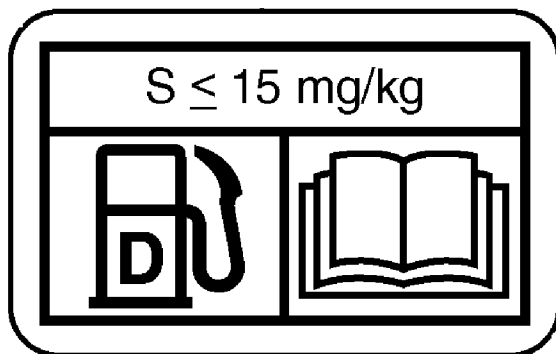

Illustration 48

g02052934

Refer to Special Publication, SEBU6251, "Caterpillar Commercial Diesel Engine Fluids Recommendations" for the Caterpillar Specification for distillate fuel and for additional information that relates to fuel for your engine. The manual can be found on the web at Safety.Cat.com.

Ultra low Sulfur Diesel (ULSD)

Your Caterpillar Diesel Engine must use ultra low sulfur diesel fuel. This fuel complies with the emissions regulations that are prescribed by the Environmental Protection Agency of the United States.

Engines that are manufactured by Caterpillar are certified with the fuel that is prescribed by the United States Environmental Protection Agency. Engines that are manufactured by Caterpillar are certified with the fuel that is prescribed by the European Certification. Caterpillar does not certify diesel engines on any other fuel.

Note: The owner and the operator of the engine has the responsibility of using the fuel that is prescribed by the United States Environmental Protection Agency and other appropriate regulatory agencies.

Fuel Additives

Many types of fuel additives are available. Caterpillar does not generally recommend the use of fuel additives.

In special circumstances, Caterpillar recognizes the need for fuel additives. Fuel additives need to be used with caution. The additive may not be compatible with the fuel. Some additives may precipitate. This action causes deposits in the fuel system. The deposits may cause seizure. Some additives may be corrosive and some additives may be harmful to the elastomers in the fuel system.

Some additives may damage emission control systems. Some additives may cause the amount of sulfur in the fuel to be greater than 15 ppm.

Contact your fuel supplier for those circumstances when fuel additives are required. Your fuel supplier can recommend the best additives for your application and for the proper level of treatment.

Note: For the best results, your fuel supplier should treat the fuel when additives are necessary.

Fuel Additives Recommendation

Caterpillar recommends the 343-6210 Cleaner for the diesel fuel must be used at 3000 hours of engine operation. Using the 343-6210 Cleaner will remove built up deposits and maintain engine power output.

Due to regional fuel variations and different usage cycles deposits may build up in shorter periods. Caterpillar recommends using the cleaner as required, if a power reduction is observed.

Coolant Recommendations

The following two coolants are used in Caterpillar diesel engines:

Preferred – Cat ELC (Extended Life Coolant) or a commercial extended life coolant that meets the Caterpillar EC-1 specification

Acceptable – A Cat DEAC (Diesel Engine Antifreeze/Coolant) or a commercial heavy-duty antifreeze that meets "ASTM D6210" specifications

NOTICE

The Caterpillar industrial engine must be operated with a 1:1 mixture of water and glycol. This concentration allows the NOx reduction system to operate correctly at high ambient temperatures.

NOTICE

Do not use a commercial coolant/antifreeze that only meets the ASTM "D3306" or equivalent specification. This type of coolant/antifreeze is made for light duty automotive applications.

Use only the coolant/antifreeze that is recommended.

Caterpillar recommends a 1:1 mixture of water and glycol. This mixture of water and glycol will provide optimum heavy-duty performance as an antifreeze.

Note: Cat DEAC does not require a treatment with an SCA at the initial fill. Commercial heavy-duty antifreeze that meets "ASTM D4985" or "ASTM D6210" specifications MAY require a treatment with an SCA at the initial fill. Read the label or the instructions that are provided by the OEM of the product.

In stationary engine applications that do not require anti-boil protection or freeze protection, a mixture of SCA and water is acceptable. Caterpillar recommends a 6 percent to 8 percent concentration of SCA in those cooling systems. Distilled water or deionized water is preferred. Water which has the recommended properties may be used.

Table 13

Coolant Service Life	
Coolant Type	Service Life ⁽¹⁾
Cat ELC	12000 Service Hours or Six Years ⁽²⁾
Commercial coolant that meets the Caterpillar EC-1 Specification	6000 Service Hours or Six Years ⁽³⁾
Cat DEAC	3000 Service Hours or Three Years
Commercial Heavy-Duty Coolant/Antifreeze that meets "ASTM D6210"	3000 Service Hours or Two Years

⁽¹⁾ Use the interval that occurs first. The cooling system must also be flushed out at this time.

⁽²⁾ Cat ELC Extender must be added at 6000 service hours or one half of the service life of the Cat ELC. Refer to your machine Operation and Maintenance Manual for exceptions.

⁽³⁾ An extender must be added at 3000 service hours or one half of the service life of the coolant.

Note: Refer to Special Publication, SEBU6251, "Caterpillar Commercial Diesel Engine Fluids Recommendations" for additional information that relates to coolant for your engine.

S-O-S Coolant Analysis

Table 14

Recommended Interval		
Type of Coolant	Level 1	Level 2
DEAC	Every 250 Hours	Yearly ⁽¹⁾
ELC	Not Required	Yearly

⁽¹⁾ The Level 2 Coolant Analysis should be performed sooner if a problem is identified by a Level 1 Coolant Analysis.

S-O-S Coolant Analysis (Level 1)

A coolant analysis (Level 1) is a test of the properties of the coolant.

The following properties of the coolant are tested:

- Glycol concentration for freeze protection and boil protection
- Ability to protect from erosion and corrosion
- pH
- Conductivity
- Visual analysis
- Odor analysis

The results are reported, and appropriate recommendations are made.

Refer to the Maintenance Interval Schedule in this Operation and Maintenance Manual to find the maintenance interval for collecting the coolant samples.

S-O-S Coolant Analysis (Level 2)

A coolant analysis (Level 2) is a comprehensive chemical evaluation of the coolant. This analysis is also a check of the overall condition of the inside of the cooling system.

The S-O-S Coolant Analysis has the following features:

- Full coolant analysis (Level 1)
- Identification of the source of metal corrosion and of contaminants
- Water hardness
- Identification of buildup of the impurities that cause corrosion
- Identification of buildup of the impurities that cause scaling

The results are reported, and appropriate recommendations are made.

Refer to the Maintenance Interval Schedule in this Operation and Maintenance Manual, "Cooling System Coolant Sample (Level 2) - Obtain" for the maintenance interval for collecting the coolant samples.

Testing the engine coolant is important to ensure that the engine is protected from internal cavitation and from corrosion. The analysis also tests the ability of the coolant to protect the engine from boiling and from freezing. The S·O·S Coolant Analysis can be done at your Caterpillar dealer. Caterpillar S·O·S Coolant Analysis is the best way to monitor the condition of your coolant and your cooling system. S·O·S Coolant Analysis is a program that is based on periodic samples.

Refer to Special Publication, SEBU6251, "Caterpillar Commercial Diesel Engine Fluids Recommendations" for additional information.

Maintenance Recommendations

i07819420

System Pressure Release

SMCS Code: 1250; 1300; 1350; 5050

Coolant System

WARNING

Pressurized system: Hot coolant can cause serious burn. To open cap, stop engine, wait until radiator is cool. Then loosen cap slowly to relieve the pressure.

WARNING

When the engine is in the AUTOMATIC mode, the engine can start at any moment. To avoid personal injury, always remain clear of the the engine when the engine is in the AUTOMATIC mode.

The engine can have the ability to auto start. Ensure that the power supply is isolated before any service or repair is performed.

To relieve the pressure from the coolant system, turn off the engine. Allow the cooling system pressure cap to cool. Remove the cooling system pressure cap slowly to relieve pressure.

Fuel System

To relieve the pressure from the fuel system, turn off the engine.

High-Pressure Fuel Lines

WARNING

Contact with high pressure fuel may cause fluid penetration and burn hazards. High pressure fuel spray may cause a fire hazard. Failure to follow these inspection, maintenance and service instructions may cause personal injury or death.

The high-pressure fuel lines are the fuel lines that are between the high-pressure fuel pump and the high-pressure fuel manifold and the fuel lines that are between the fuel manifold and the fuel injectors.

The high-pressure fuel lines are different from fuel lines on other fuel systems, the differences are as follows:

- The high-pressure fuel lines are constantly charged with high pressure.
- The internal pressures of the high-pressure fuel lines are higher than other types of fuel system.

Before any service or repair is performed on the engine fuel lines, perform the following tasks:

1. Stop the engine.
2. Wait for 10 minutes.

Do not loosen the high-pressure fuel lines to remove air from the fuel system.

Engine Oil

To relieve pressure from the lubricating system, turn off the engine.

i07980095

Welding on Engines with Electronic Controls

SMCS Code: 1000

Correct welding procedures are necessary to avoid damage to the engines ECM, sensors, and associated components. When possible, remove the component from the unit and then weld the component. If removal of the component is not possible, the following procedure must be followed when you weld on a unit equipped with an Electronic Engine. The following procedure is considered to be the safest procedure to weld on a component. This procedure should provide a minimum risk of damage to electronic components.

NOTICE

Do not ground the welder to electrical components such as the ECM or sensors. Improper grounding can cause damage to the drive train bearings, hydraulic components, electrical components, and other components.

Clamp the ground cable from the welder to the component that will be welded. Place the clamp as close as possible to the weld. This will help reduce the possibility of damage.

Note: Perform the welding in areas that are free from explosive hazards.

1. Stop the engine. Turn the switched power to the OFF position.
2. Ensure that the fuel supply to the engine is turned off.

3. Disconnect the negative battery cable from the battery. If a battery disconnect switch is provided, open the switch.
4. Disconnect all electronic components from the wiring harnesses. Include the following components:
 - Electronic components for the driven equipment
 - ECM
 - Sensors
 - Electric operated fuel pump
 - Electronically controlled valves
 - Relays
 - Aftertreatment ID module

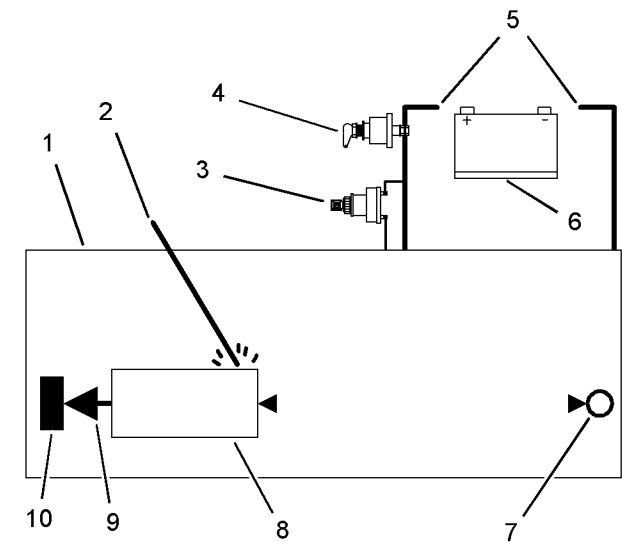

Illustration 49

g06477753

NOTICE
Do not use electrical components (ECM or ECM sensors) or electronic component grounding points for grounding the welder.

Use the example above. The current flow from the welder to the ground clamp of the welder will not damage any associated components.

- (1) Engine
- (2) Welding electrode
- (3) Keyswitch in the OFF position
- (4) Battery disconnect switch in the open position
- (5) Disconnected battery cables
- (6) Battery
- (7) Electrical/Electronic component
- (8) The component that is being welded
- (9) Current path of the welder
- (10) Ground clamp for the welder

5. Connect the welding ground cable directly to the part that will be welded. Place the ground cable as close as possible to the weld to reduce the possibility of welding current damage to the following components. Bearings, hydraulic components, electrical components, and ground straps.

Note: If electrical/electronic components are used as a ground for the welder, or electrical/electronic components are located between the welder ground and the weld, current flow from the welder could severely damage the component.

6. Protect the wiring harness from welding debris and spatter.
7. Use standard welding practices to weld the materials.

i06936314

Severe Service Application

SMCS Code: 1000

Severe service is the application of an engine that exceeds the current published standards for that engine. Caterpillar maintains standards for the following engine parameters:

- Performance such as power range, speed range, and fuel consumption
- Fuel quality
- Operational Altitude
- Maintenance intervals
- Oil selection and maintenance
- Coolant type and maintenance
- Environmental qualities
- Installation
- The temperature of the fluid in the engine

Refer to the standards for the engine or consult your Cat dealer to determine if the engine is operating within the defined parameters.

Severe service operation can accelerate component wear. Engines that operate under severe conditions may need more frequent maintenance intervals to ensure maximum reliability and retention of full service life.

Due to individual applications, it is not possible to identify all the factors which can contribute to severe service operation. Consult your Cat dealer for the unique maintenance that is necessary for the engine.

The operating environment, incorrect operating procedures, and incorrect maintenance procedures can be factors which contribute to a severe service application.

Environmental Factors

Ambient temperatures – The engine may be exposed to extended operation in extremely cold environments or hot environments. Valve components can be damaged by carbon buildup if the engine is frequently started and stopped in very cold temperatures. Extremely hot intake air reduces engine performance.

Quality of the air – The engine may be exposed to extended operation in an environment that is dirty or dusty, unless the equipment is cleaned regularly. Mud, dirt, and dust can encase components. Maintenance can be very difficult. The buildup can contain corrosive chemicals.

Buildup – Compounds, elements, corrosive chemicals, and salt can damage some components.

Altitude – Problems can arise when the engine is operated at altitudes that are higher than the intended settings for that application. Necessary adjustments should be made.

Incorrect Operating Procedures

- Extended operation at low idle
- Frequent hot shutdowns
- Frequent stop/starts exceeding 10 engine starts in 1-hour period
- Operating at excessive loads
- Operating at excessive speeds
- Operating outside the intended application
- Operating with fuel which does not meet the standards for distillate diesel fuel as stated in Special Publication, SEBU6250, "Caterpillar Machine Fluids Recommendations" "Distillate Diesel Fuel"
- Operating with a blend of distillate fuel which contains more than 20 percent biodiesel

Incorrect Maintenance Procedures

- Extending the maintenance intervals
- Failure to use recommended fuel, lubricants, and coolant/antifreeze

i10061523

Maintenance Interval Schedule

SMCS Code: 1000; 7500

When Required

- " Battery - Replace" 81
- " Battery or Battery Cable - Disconnect" 82
- " Engine - Clean" 101
- " Fuel System - Prime" 109

Daily

- " Cooling System Coolant Level - Check" 93
- " Engine Air Cleaner Service Indicator - Inspect" 103
- " Engine Air Precleaner - Check/Clean" 104
- " Engine Oil Level - Check" 105
- " Fuel System Primary Filter/Water Separator - Drain" 115
- " Fuel System Primary Filter/Water Separator - Drain" 114
- " Fuel System Secondary Filter/Water Separator - Drain" 118
- " Walk-Around Inspection" 123

Every 50 Service Hours or Weekly

- " Fuel Tank Water and Sediment - Drain" 118

Every 250 Service Hours

- " Cooling System Coolant Sample (Level 1) - Obtain" 96
- " Engine Oil Sample - Obtain" 105

Every 500 Service Hours

- " Engine Air Cleaner Element - Replace" 102
- " Fan Clearance - Check" 108

Every 500 Service Hours or 1 Year

- " Battery Electrolyte Level - Check" 82
- " Belts - Inspect/Adjust" 83
- " Engine Oil and Filter - Change" 106

- " Fuel System Primary Filter (Water Separator) Element - Replace" 112
- " Fuel System Primary Filter (Water Separator) Element - Replace" 111
- " Fuel System Secondary Filter - Replace" 116
- " Hoses and Clamps - Inspect/Replace" 119
- " Radiator - Clean" 121
- " Belts - Inspect/Adjust" 83

Every 1000 Service Hours

- " Alternator and Fan Belts - Replace" 77
- " Alternator and Fan Belts - Replace" 80
- " Engine Valve Lash - Check" 108
- " Turbocharger - Inspect" 123

Every 1500 Service Hours

- " Crankcase Breather (Canister) - Replace" 98
- " Crankcase Breather (Canister) - Replace" 99

Every 2000 Service Hours

- " Alternator - Inspect" 77
- " Engine Mounts - Inspect" 104
- " Radiator Mounts - Inspect" 122
- " Starting Motor - Inspect" 122

Every Year

- " Cooling System Coolant Sample (Level 2) - Obtain" 97

Every 3000 Service Hours

- " Cooling System Water Temperature Regulator - Replace" 97

“ Water Pump - Inspect“ 124

Every 3000 Service Hours or 3 Years

“ Cooling System Coolant (DEAC) - Change“ 84

Every 4000 Service Hours

“ Aftercooler Core - Inspect“ 77

Every 6000 Service Hours or 3 Years

“ Cooling System Coolant Extender (ELC) - Add“ 93

Every 12 000 Service Hours or 6 Years

“ Cooling System Coolant (ELC) - Change“ 89

Overhaul

“ Overhaul Considerations“ 120

Commissioning

“ Fan Clearance - Check“ 108

i04380914

i03641972

Aftercooler Core - Inspect

SMCS Code: 1064-040

Note: Adjust the frequency of cleaning according to the effects of the operating environment.

Inspect the aftercooler for these items: damaged fins, corrosion, dirt, grease, insects, leaves, oil and other debris. Clean the aftercooler, if necessary.

For air-to-air aftercoolers, use the same methods that are used for cleaning radiators.

WARNING

Personal injury can result from air pressure.

Personal injury can result without following proper procedure. When using pressure air, wear a protective face shield and protective clothing.

Maximum air pressure at the nozzle must be less than 205 kPa (30 psi) for cleaning purposes.

Pressurized air is the preferred method for removing loose debris. Direct the air in the opposite direction of the fans air flow. Hold the nozzle approximately 6 mm (.25 inch) away from the fins. Slowly move the air nozzle in a direction that is parallel with the tubes. The pressurized air will remove debris that is between the tubes.

Pressurized water may also be used for cleaning. The maximum water pressure for cleaning purposes must be less than 275 kPa (40 psi). Use pressurized water in order to soften mud. Clean the core from both sides.

Use a degreaser and steam for removal of oil and grease. Clean both sides of the core. Wash the core with detergent and hot water. Thoroughly rinse the core with clean water.

After cleaning, start the engine and accelerate the engine to high idle rpm. This will help in the removal of debris and drying of the core. Stop the engine. Use a light bulb behind the core in order to inspect the core for cleanliness. Repeat the cleaning, if necessary.

Inspect the fins for damage. Bent fins may be opened with a "comb".

Note: If parts of the aftercooler system are repaired or replaced, a leak test is highly recommended. For more information, refer to OEM specification for the aftercooler.

Inspect these items for good condition: welds, mounting brackets, air lines, connections, clamps and seals. Make repairs, if necessary.

Alternator - Inspect

SMCS Code: 1405-040

Caterpillar recommends a scheduled inspection of the alternator. Inspect the alternator for loose connections and proper battery charging. Inspect the ammeter (if equipped) during engine operation in order to ensure proper battery performance and/or proper performance of the electrical system. Make repairs, as required.

Check the alternator and the battery charger for proper operation. If the batteries are properly charged, the ammeter reading should be very near zero. All batteries should be kept charged. The batteries should be kept warm because temperature affects the cranking power of the battery. If the battery is too cold, the battery will not crank the engine.

When the engine is not run for long periods of time or if the engine is run for short periods, the batteries may not fully charge. A battery with a low charge will freeze more easily than a battery with a full charge.

i08088416

Alternator and Fan Belts - Replace (Multi-V Stretch Belt)

SMCS Code: 1357-510

Removal Procedure

NOTICE

Keep all parts clean from contaminants.

Contaminants may cause rapid wear and shortened component life.

1. If the engine is equipped with fan guards, remove the fan guards. Refer to your Caterpillar dealer for further assistance.

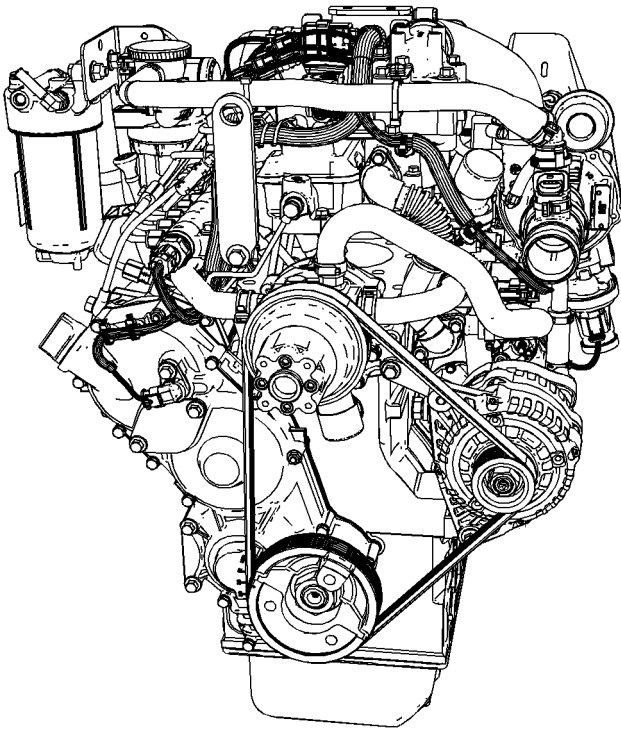

Illustration 50

g06539706

Typical example of belt routing for the Multi-V stretch belt option.

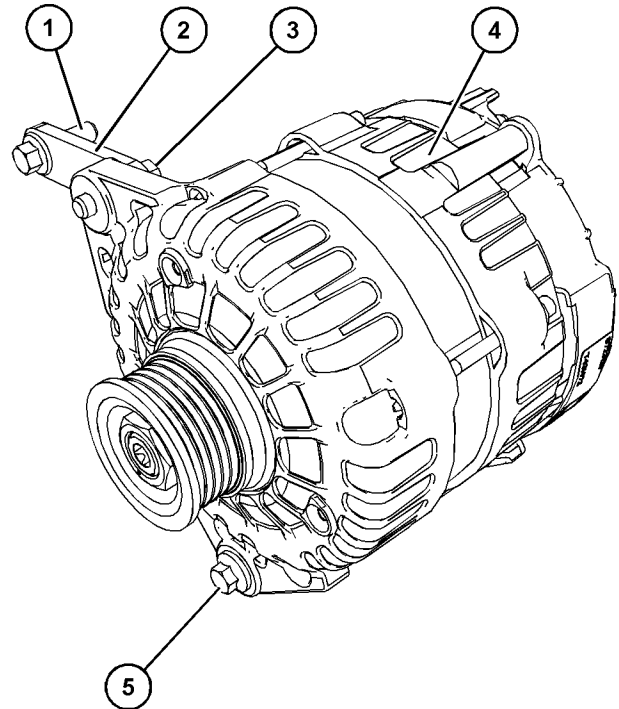

Illustration 51

g06473107

Typical example

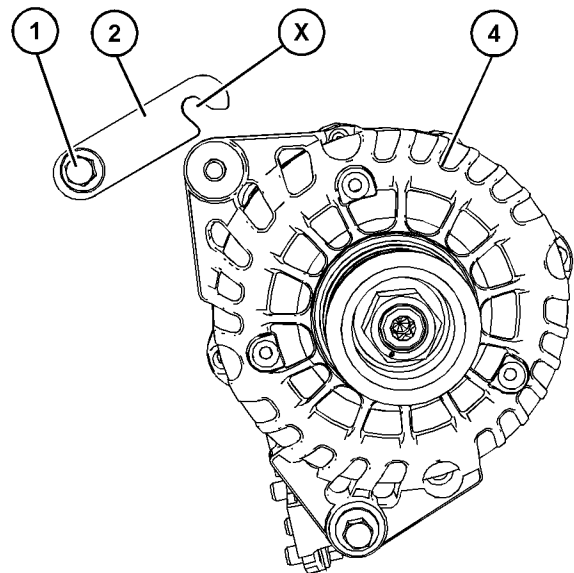

Illustration 52

g06474305

2. Loosen bolt (1) and bolt (3) on link lever (2) two complete turns in an anti-clockwise direction.
3. Loosen bolt (5) two complete turns in an anti-clockwise direction.

4. Rotate link lever (2) anti-clockwise to release bolt (3) from the cut-out in Position (X).
5. Rotate alternator (4) towards the cylinder block to remove the alternator belt. Discard the alternator belt.

Installation Procedure

NOTICE

Keep all parts clean from contaminants.

Contaminants may cause rapid wear and shortened component life.

The multi-v Front End Auxiliary Drive (FEAD) may show signs of belt dusting and reformed solid within pulley and belt grooves under bedding-in where ambient airflow is not sufficient to clear the dusting. This dusting is an expected characteristic, the pulley, and belt should run clear beyond 100 hours.

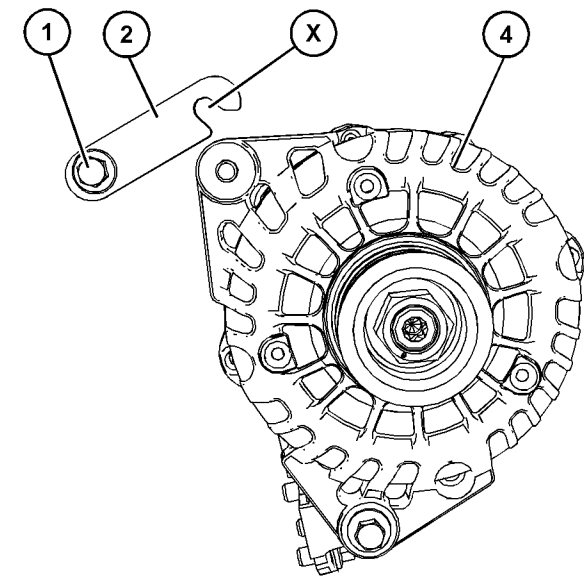

Illustration 54

g06474305

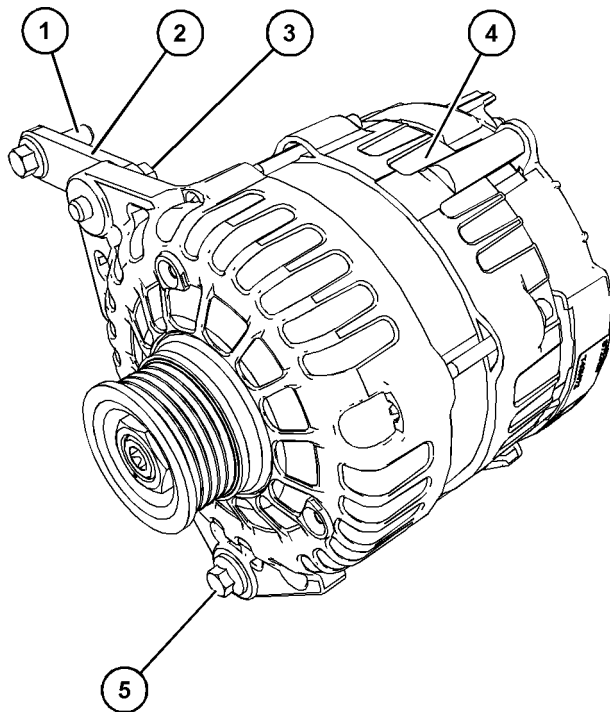

Illustration 53

g06473107

Typical example

1. Clean the grooves in all the pulleys and remove any dirt, debris, or build-up that may have accumulated from the old belt.
2. Position the new alternator belt onto the pulleys. Refer to Illustration 50 for the correct routing around the pulleys.

Note: Ensure that the alternator belt is not twisted and is correctly positioned in the pulley grooves.

3. Use a suitable tool to position the alternator away from the cylinder block engage the cut-out in Position (X) in link lever (2) with bolt (3). Tighten bolt (3).

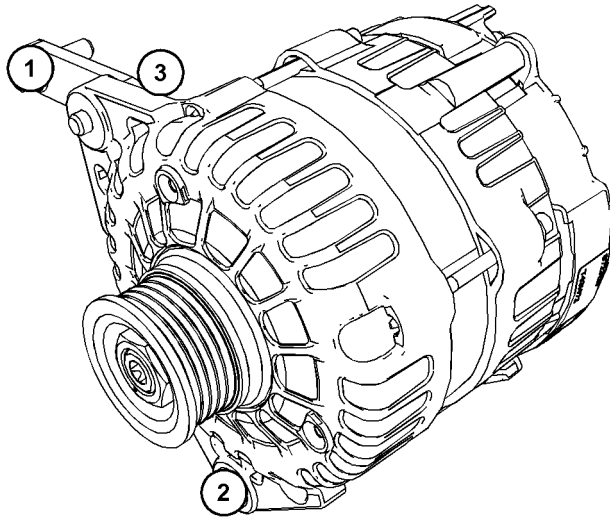

Illustration 55

g06474149

4. Tighten bolt (1), bolt (5), and bolt (3) in the sequence shown in Illustration 55 to a torque of 22 N·m (195 lb in)
5. If the engine is equipped with fan guards, install the fan guards. Refer to your Caterpillar dealer for further assistance.

i08088488

Alternator and Fan Belts - Replace (Single-V Belt)

SMCS Code: 1357-510

Removal Procedure

1. If the engine is equipped with fan guards, remove the fan guards. Refer to your Caterpillar dealer for further assistance.

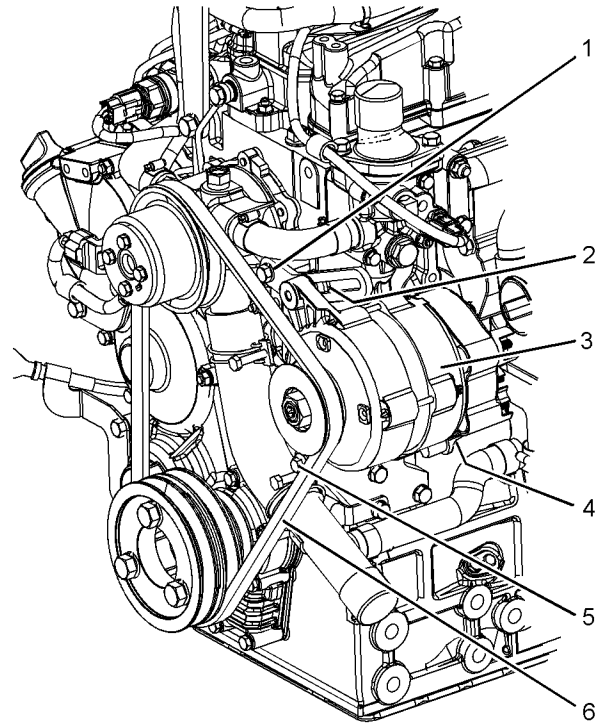

Illustration 56

g06540190

Typical example

2. Loosen bolt (1) and bolt (2) (not shown) on the adjuster link.
3. Loosen nut (4) (not shown) and bolt (5).

4. Push alternator (3) toward the engine and remove alternator belt (6).

Installation Procedure

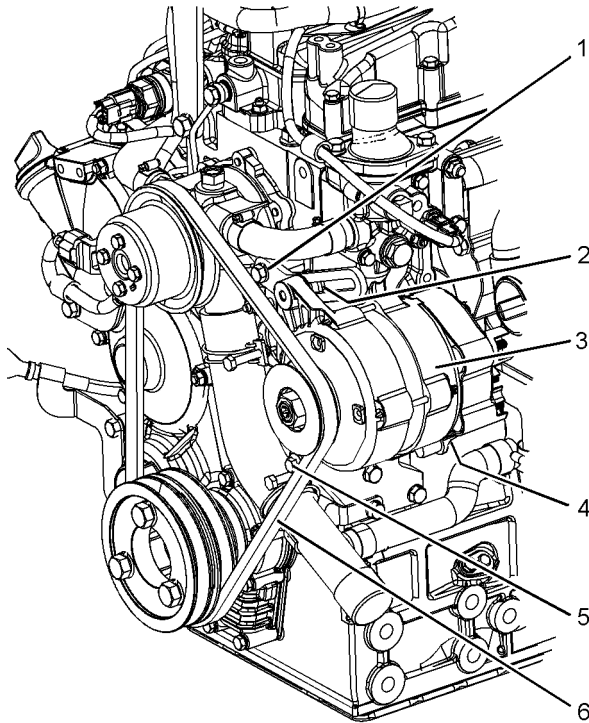

Illustration 57

g06540190

Typical example

1. Position alternator belt (6) onto alternator (3), the water pump pulley, and the crankshaft pulley. Ensure that the alternator belt is correctly positioned onto the alternator pulley, the water pump pulley, and the crankshaft pulley, refer to Illustration 56 .
2. Slide alternator (3) away from the engine to tighten belt (6) to the correct tension.

The belt tension for a new belt is from 400 N to 489 N (90 lb to 110 lb).
3. Tighten bolt (1), bolt (2) to a torque of 25 N·m (221 lb in).
4. Tighten nut (4) (not shown) and bolt (5) to a torque of 25 N·m (221 lb in).
5. If the engine is equipped with fan guards, install the fan guards. Refer to your Caterpillar dealer for further assistance.

Note: When a new belt is installed, check the belt tension again after 20 hours of engine operation.

For applications that require multiple drive belts, replace the belts in matched sets.

i02322315

Battery - Replace

SMCS Code: 1401-510

⚠ WARNING

Batteries give off combustible gases which can explode. A spark can cause the combustible gases to ignite. This can result in severe personal injury or death.

Ensure proper ventilation for batteries that are in an enclosure. Follow the proper procedures in order to help prevent electrical arcs and/or sparks near batteries. Do not smoke when batteries are serviced.

⚠ WARNING

The battery cables or the batteries should not be removed with the battery cover in place. The battery cover should be removed before any servicing is attempted.

Removing the battery cables or the batteries with the cover in place may cause a battery explosion resulting in personal injury.

1. Switch the engine to the OFF position. Remove all electrical loads.
 2. Turn off any battery chargers. Disconnect any battery chargers.
 3. The NEGATIVE “-” cable connects the NEGATIVE “-” battery terminal to the NEGATIVE “-” terminal on the starting motor. Disconnect the cable from the NEGATIVE “-” battery terminal.
 4. The POSITIVE “+” cable connects the POSITIVE “+” battery terminal to the POSITIVE “+” terminal on the starting motor. Disconnect the cable from the POSITIVE “+” battery terminal.
- Note:** Always recycle a battery. Never discard a battery. Dispose of used batteries to an appropriate recycling facility.
5. Remove the used battery.
 6. Install the new battery.
- Note:** Before the cables are connected, ensure that the engine start switch is OFF.
7. Connect the cable from the starting motor to the POSITIVE “+” battery terminal.

8. Connect the NEGATIVE “-” cable to the NEGATIVE “-” battery terminal.

i09570426

i02724529

Battery Electrolyte Level - Check

SMCS Code: 1401-535

When the engine is not run for long periods of time or when the engine is run for short periods, the batteries may not fully recharge. Ensure a full charge in order to help prevent the battery from freezing. If batteries are properly charged, ammeter reading should be very near zero, when the engine is in operation.

WARNING

All lead-acid batteries contain sulfuric acid which can burn the skin and clothing. Always wear a face shield and protective clothing when working on or near batteries.

1. Remove the filler caps. Maintain the electrolyte level to the “FULL” mark on the battery.
 If the addition of water is necessary, use distilled water. If distilled water is not available use clean water that is low in minerals. Do not use artificially softened water.
2. Check the condition of the electrolyte with the 245 - 5829 Coolant Battery Tester Refractometer.
3. Keep the batteries clean.

Clean the battery case with one of the following cleaning solutions:

- Use a solution of 0.1 kg (0.2 lb) baking soda and 1 L (1 qt) of clean water.
- Use a solution of ammonium hydroxide.

Thoroughly rinse the battery case with clean water.

Use a fine grade of sandpaper to clean the terminals and the cable clamps. Clean the items until the surfaces are bright or shiny. DO NOT remove material excessively. Excessive removal of material can cause the clamps to not fit properly. Coat the clamps and the terminals with 5N - 5561 Silicone Lubricant, petroleum jelly or MPGM.

Battery or Battery Cable - Disconnect

SMCS Code: 1402-029

WARNING

The battery cables or the batteries should not be removed with the battery cover in place. The battery cover should be removed before any servicing is attempted.

Removing the battery cables or the batteries with the cover in place may cause a battery explosion resulting in personal injury.

1. Turn the start switch to the OFF position. Turn the ignition switch (if equipped) to the OFF position and remove the key and all electrical loads.
2. Open the battery isolator. Disconnect the negative battery terminal. Ensure that the cable cannot contact the terminal. When four 12 volt batteries are involved, two negative connections must be disconnected.
3. Remove the positive connection.
4. Clean all disconnected connection and battery terminals.
5. Use a fine grade of sandpaper to clean the terminals and the cable clamps. Clean the items until the surfaces are bright or shiny. DO NOT remove material excessively. Excessive removal of material can cause the clamps to not fit correctly. Coat the clamps and the terminals with a suitable silicone lubricant or petroleum jelly.
6. Tape the cable connections to help prevent accidental starting.
7. Proceed with necessary system repairs.
8. To connect the battery, connect the positive connection before the negative connection.

i08088477

Belts - Inspect/Adjust (Multi-V Stretch Belt)

SMCS Code: 1357-025; 1357-040

Inspection

The Multi-vee Front End Auxiliary Drive (FEAD) may show signs of belt dusting and reformed solid within pulley and belt grooves under bedding-in where ambient airflow is not sufficient to clear the dusting. This dusting is an expected characteristic, the pulley, and belt should run clear beyond 100 hours.

To maximize the engine performance, inspect the belt for wear and for cracking. Replace a belt that is worn or damaged.

If the belt is too loose, vibration causes unnecessary wear on the belt and pulleys. A loose belt may slip enough to cause overheating.

If a multi-v stretch belt is too loose, the belt must be replaced with a new one.

i08455108

Belts - Inspect/Adjust

SMCS Code: 1357-025; 1357-040

Inspection

To maximize the engine performance, inspect the belt for wear and for cracking. Replace a belt that is worn or damaged.

If the belt is too loose, vibration causes unnecessary wear on the belt and pulleys. A loose belt may slip enough to cause overheating.

To accurately check the belt tension, 144-0235 Belt Tension Gauge should be used.

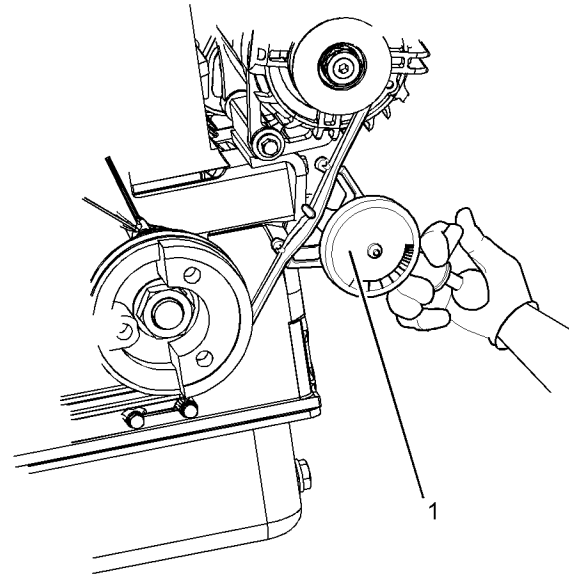

Illustration 58

g03383147

Typical example

(1) 144-0235 Belt Tension Gauge

Install the gauge (1) at the center of the belt between the alternator and the crankshaft pulley and check the belt tension. The correct tension for a new belt on a specific engine is detailed in table 15 . The correct tension for a used belt on a specific engine that has been in operation for 30 minutes or more at the rated speed is detailed in table 15 .

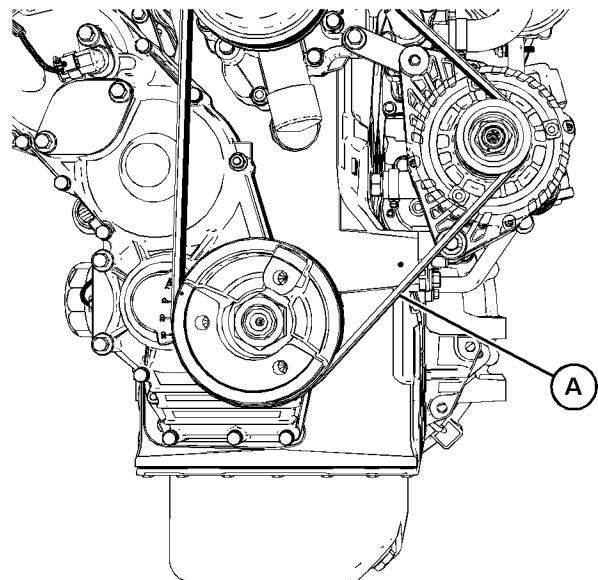

Illustration 59

g06582287

Typical example

Maintenance Section
Cooling System Coolant (DEAC) - Change

For inspections that are done with a suitable belt frequency meter, install the belt frequency meter on the span of the belt at Position "A". Refer to table 15 for the correct frequency for a new belt or used belt on a specific engine. Table 15 also gives the approximate span of belt between crankshaft pulley and alternator pulley.

Table 15

Alternator Belt Tension and Frequency					
Engine Model	Approximate Span (mm)	New belt		Used Belt	
		Frequency (Hz)	Tension (Nm) and (lb)	Frequency (Hz)	Tension (Nm) and (lb)
C1.7	215 mm - 225 mm	150-170 Hz	400 to 489 N (90 to 110 lb)	130-145 Hz	267 to 356 N (60 to 80 lb)
C2.2	236 mm - 247 mm	130-150 Hz	400 to 489 N (90 to 110 lb)	110-130 Hz	267 to 356 N (60 to 80 lb)

Adjust

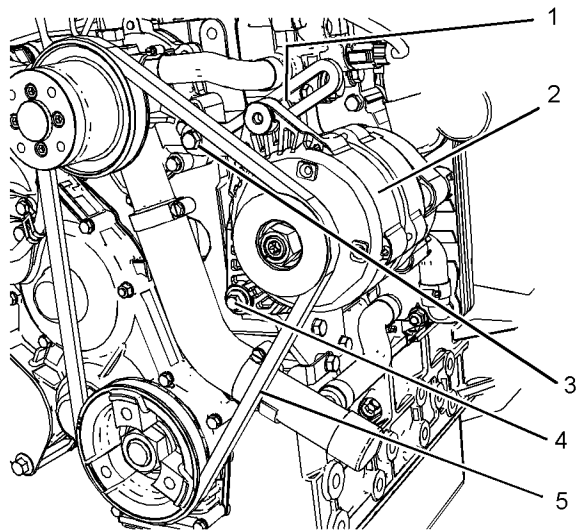

Illustration 60

g03886616

Typical example

1. Loosen bolt (1) and loosen bolt (3).
2. Loose nut and bolt (4).
3. Move the alternator (2) to adjust the belt (5) to the required tension.

4. Tighten bolt (1) and bolt (3) to a torque of 22 N·m (194 lb in). Tighten nut and bolt (4) to a torque of 22 N·m (194 lb in).

i09670098

Cooling System Coolant (DEAC) - Change

SMCS Code: 1350-070; 1395-044

Clean the cooling system and flush the cooling system before the recommended maintenance interval if the following conditions exist:

- The engine overheats frequently.
- Foaming is observed.
- The oil has entered the cooling system and the coolant is contaminated.
- The fuel has entered the cooling system and the coolant is contaminated.

NOTICE

Use of commercially available cooling system cleaners may cause damage to cooling system components. Use only cooling system cleaners that are approved for Caterpillar engines.

Note: Inspect the water pump and the water temperature regulator after the cooling system has been drained. This inspection is a good opportunity to replace the water pump, the water temperature regulator, and the hoses, if necessary.

Drain

WARNING

Pressurized System: Hot coolant can cause serious burns. To open the cooling system filler cap, stop the engine and wait until the cooling system components are cool. Loosen the cooling system pressure cap slowly in order to relieve the pressure.

1. Stop the engine and allow the engine to cool.
Loosen the cooling system filler cap slowly to relieve any pressure. Remove the cooling system filler cap.

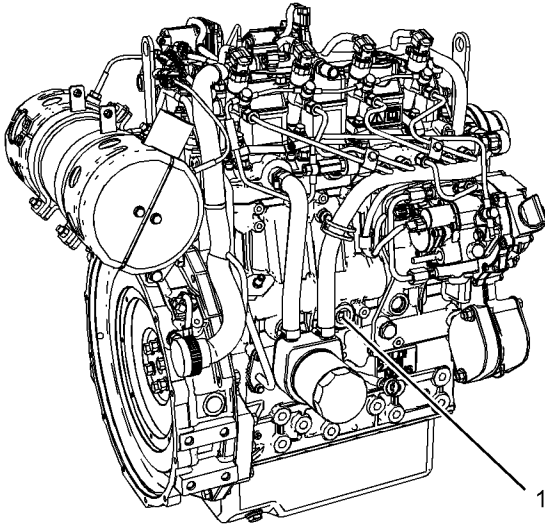

Illustration 61

g03890108

Typical example

Note: Refer to Operation and Maintenance Manual, “General Hazard Information” for information on Containing Fluid Spillage.

2. Open the cooling system drain valve (if equipped).
If the cooling system is not equipped with a drain valve, remove one of the drain plugs (1).

Allow the coolant to drain into a suitable container.
3. Properly dispose of the drained material. Obey local regulations for the disposal of the material.

NOTICE

Dispose of used engine coolant properly or recycle. Various methods have been proposed to reclaim used coolant for reuse in engine cooling systems. The full distillation procedure is the only method acceptable by Caterpillar to reclaim the used coolant.

Drain Plugs for OPU Radiators

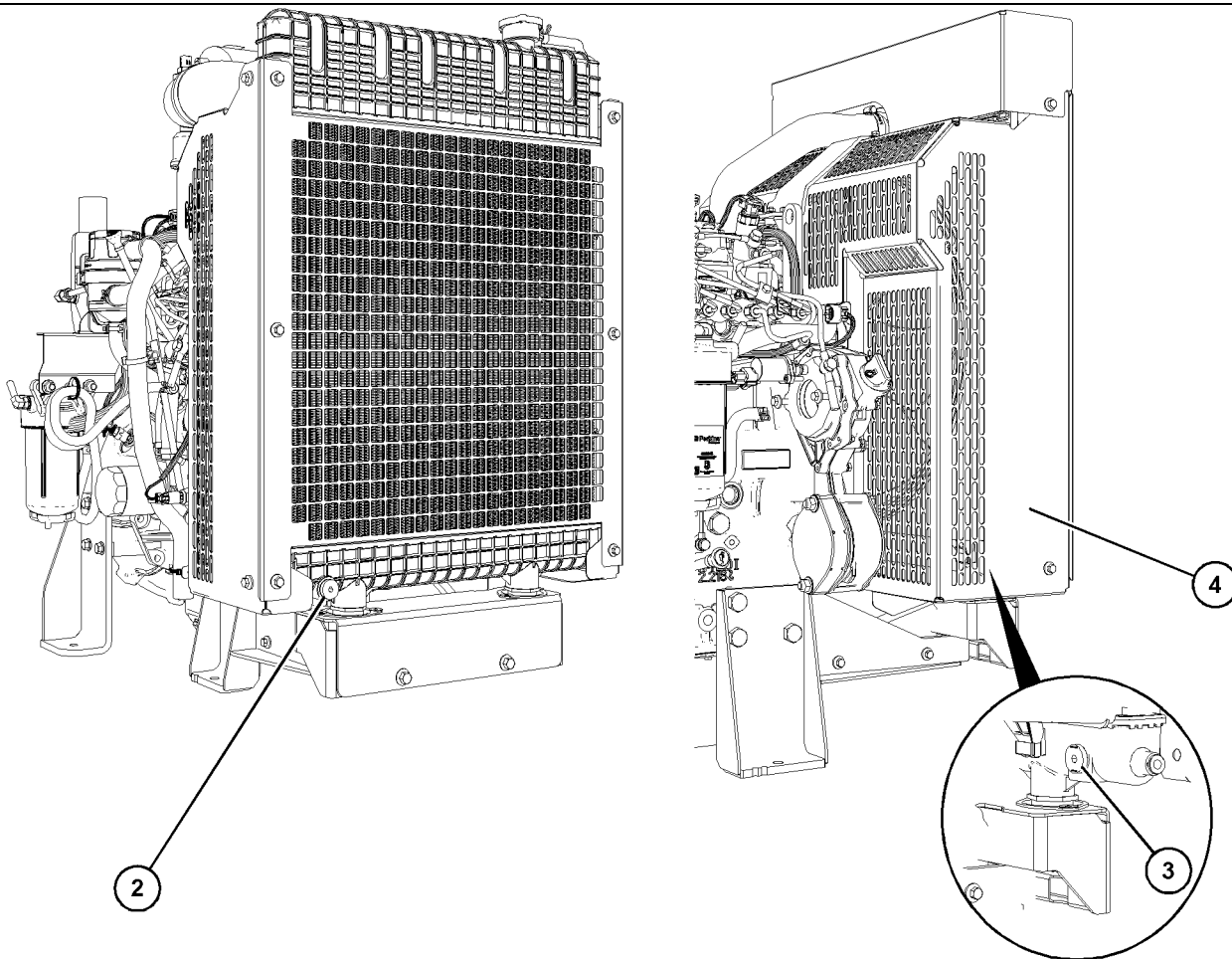

Illustration 62

g07522440

Typical example

(2) Three cylinder OPU radiator drain plug (3) Four cylinder OPU radiator drain plug

Remove fan guard (4) to get access to the drain plug (3) for the 4 cylinder OPU radiator.

- Tighten drain plug (2) and drain plug (3) to a torque of 4 N·m (35.4 lb in)

Drain Plugs for Factory Installed Radiators

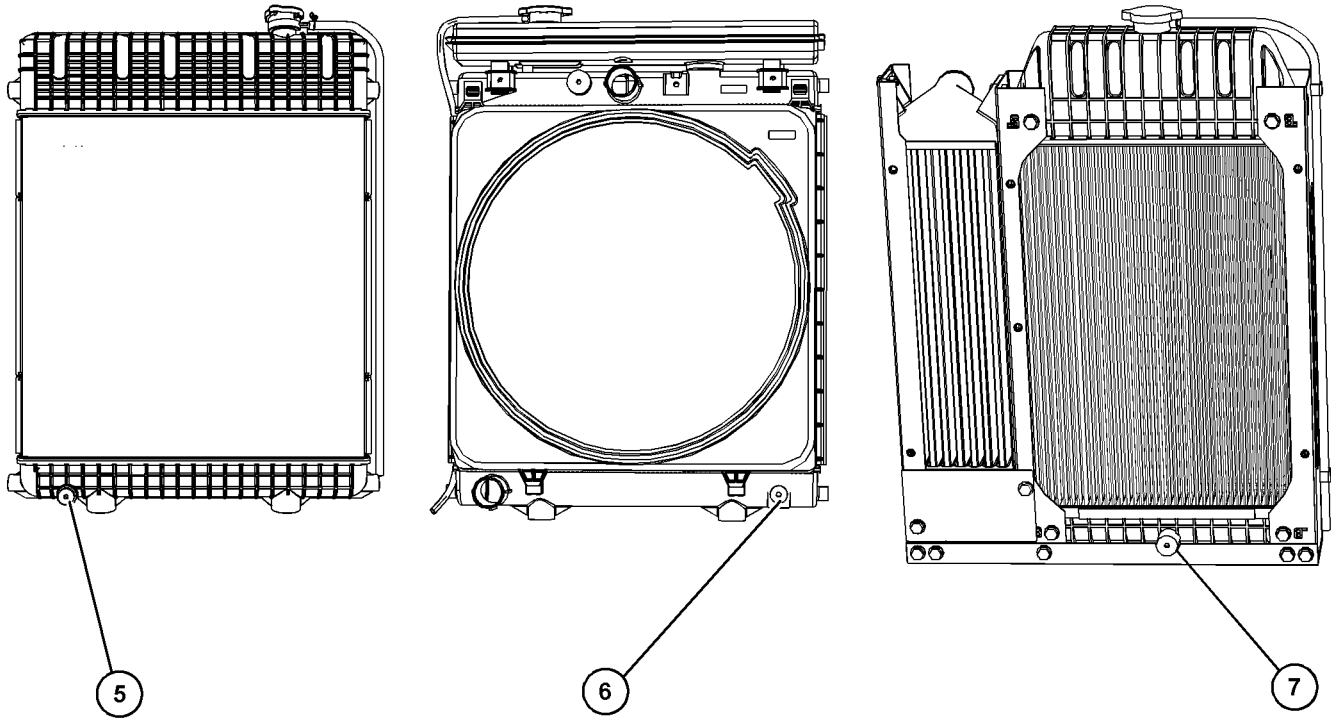

Illustration 63

g07536716

Typical example

(5) Three cylinder engine radiator drain plug

(6) Four cylinder turbocharged engine radiator drain plug

(7) Four cylinder turbocharged aftercooled engine drain plug front of radiator

- Tighten drain plug (5) to a torque of 4 N·m (35.4 lb in)
- Tighten drain plug (6) to a torque of 4 N·m (35.4 lb in)
- Tighten drain plug (7) to a torque of 6 N·m (53. lb in)

Flush

1. Flush the cooling system with clean water to remove any debris.
2. Close the drain valve (if equipped). Clean the drain plugs. Install the drain plugs. Refer to Torque Specifications, SENR3130 for more information on the correct torques.

NOTICE

Do not fill the cooling system faster than 5 L (1.3 US gal) per minute to avoid air locks.

Cooling system air locks may result in engine damage.

3. Fill the cooling system with a mixture of clean water and Caterpillar Fast Acting Cooling System Cleaner. Add 0.5 L (1 pint) of cleaner per 15 L (4 US gal) of the cooling system capacity. Install the cooling system filler cap.
4. Start and run the engine at low idle for a minimum of 30 minutes. The coolant temperature should be at least 82 °C (180 °F).

NOTICE

Improper or incomplete rinsing of the cooling system can result in damage to copper and other metal components.

To avoid damage to the cooling system, make sure to completely flush the cooling system with clear water. Continue to flush the system until all signs of the cleaning agent are gone.

5. Stop the engine and allow the engine to cool. Loosen the cooling system filler cap slowly to relieve any pressure. Remove the cooling system filler cap. Open the drain valve (if equipped) or remove the cooling system drain plugs. Allow the water to drain. Flush the cooling system with clean water. Close the drain valve (if equipped). Clean the drain plugs. Install the drain plugs. Refer to Torque Specifications, SENR3130 for more information on the correct torques.

Cooling Systems with Heavy Deposits or Plugging

Note: For the following procedure to be effective, there must be some active flow through the cooling system components.

1. Flush the cooling system with clean water to remove any debris.
 2. Close the drain valve (if equipped). Clean the drain plugs. Install the drain plugs. Refer to Torque Specifications, SENR3130 for more information on the correct torques.
-

NOTICE

Do not fill the cooling system faster than 5 L (1.3 US gal) per minute to avoid air locks.

Cooling system air locks may result in engine damage.

3. Fill the cooling system with a mixture of clean water and Caterpillar Fast Acting Cooling System Cleaner. Add 0.5 L (1 pint) of cleaner per 3.8 L to 7.6 L (1 to 2 US gal) of the cooling system capacity. Install the cooling system filler cap.
4. Start and run the engine at low idle for a minimum of 90 minutes. The coolant temperature should be at least 82 °C (180 °F).

NOTICE

Improper or incomplete rinsing of the cooling system can result in damage to copper and other metal components.

To avoid damage to the cooling system, make sure to completely flush the cooling system with clear water. Continue to flush the system until all signs of the cleaning agent are gone.

5. Stop the engine and allow the engine to cool. Loosen the cooling system filler cap slowly to relieve any pressure. Remove the cooling system filler cap. Open the drain valve (if equipped) or remove the cooling system drain plugs. Allow the water to drain. Flush the cooling system with clean water. Close the drain valve (if equipped). Clean the drain plugs. Install the drain plugs. Refer to Torque Specifications, SENR3130 for more information on the correct torques.

Fill

NOTICE

Do not fill the cooling system faster than 5 L (1.3 US gal) per minute to avoid air locks.

Cooling system air locks may result in engine damage.

1. Fill the cooling system with the coolant/antifreeze. Refer to this Operation and Maintenance Manual, "Refill Capacities and Recommendations" topic (Maintenance Section) for more information on cooling system specifications. Do not install the cooling system filler cap.
2. Start and run the engine at low idle. Increase the engine rpm to 1500 rpm. Run the engine at high idle for 1 minute to purge the air from the cavities of the engine block. Stop the engine.
3. Maintain the coolant level at the maximum mark that is correct for your application. For more information, refer to this Operation and Maintenance Manual, "Coolant Level - Check".

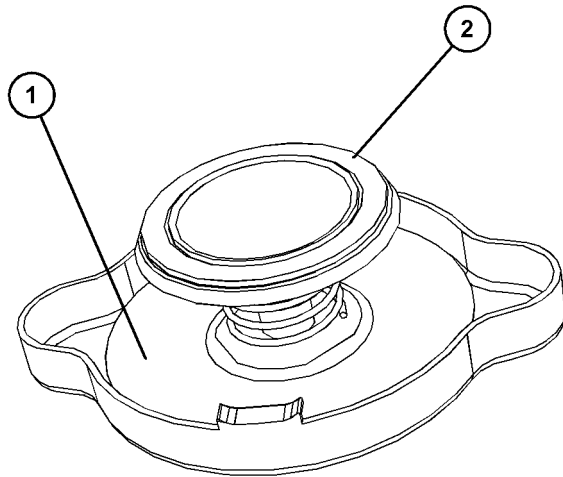

Illustration 64

g06165279

Typical example

4. Clean the cooling system filler cap and check the condition of the filler cap gasket (2). Replace the cooling system filler cap if the filler cap gasket (2) and sealing surface (1) are damaged. If the cooling system filler cap is not damaged, perform a pressure test on the filler cap.

OPU radiators

The cooling system filler cap pressure for OPU radiators on both the three cylinder engine and four cylinder engine is 110 kPa (15.9 psi).

Factory installed radiators

- Radiator cap pressure for both the three cylinder engine and four cylinder engine is 110 kPa (15.9 psi).

If the cooling system filler cap passes the pressure test check, install the filler cap. If required install new cooling system filler cap.

5. Start the engine. Inspect the cooling system for leaks and for the correct operating temperature.

i09670135

Cooling System Coolant (ELC) - Change

SMCS Code: 1350-070; 1395-044

Clean the cooling system and flush the cooling system before the recommended maintenance interval if the following conditions exist:

- The engine overheats frequently.
- Foaming is observed.
- The oil has entered the cooling system and the coolant is contaminated.
- The fuel has entered the cooling system and the coolant is contaminated.

Note: When the cooling system is cleaned, only clean water is needed when the ELC is drained and replaced.

Note: Inspect the water pump and the water temperature regulator after the cooling system has been drained. This inspection is a good opportunity to replace the water pump, the water temperature regulator, and the hoses, if necessary.

Drain

WARNING

Pressurized System: Hot coolant can cause serious burns. To open the cooling system filler cap, stop the engine and wait until the cooling system components are cool. Loosen the cooling system pressure cap slowly in order to relieve the pressure.

1. Stop the engine and allow the engine to cool. Loosen the cooling system filler cap slowly to relieve any pressure. Remove the cooling system filler cap.

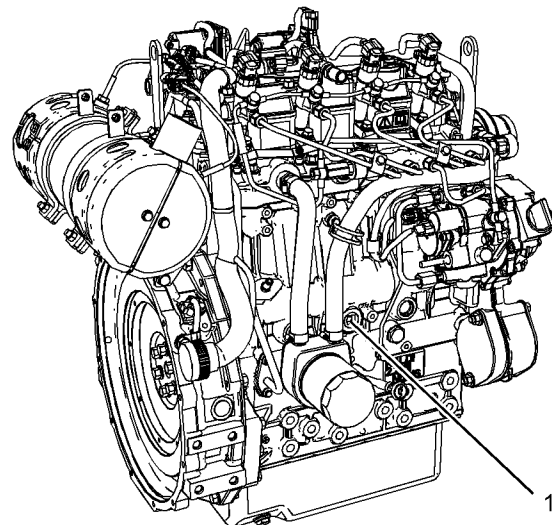

Illustration 65

g03890108

Typical example

Maintenance Section
Cooling System Coolant (ELC) - Change

- Remove drain plug (1) on the engine. Open the drain cock or remove the drain plug on the radiator.

Allow the coolant to drain.

- Refer to OEM for the drain location for your application.

NOTICE

Dispose of used engine coolant properly or recycle. Various methods have been proposed to reclaim used coolant for reuse in engine cooling systems. The full distillation procedure is the only method acceptable by Caterpillar to reclaim the used coolant.

For information regarding the disposal and the recycling of used coolant, consult your Cat dealer or consult Dealer Service Tools.

Drain Plugs for OPU Radiators

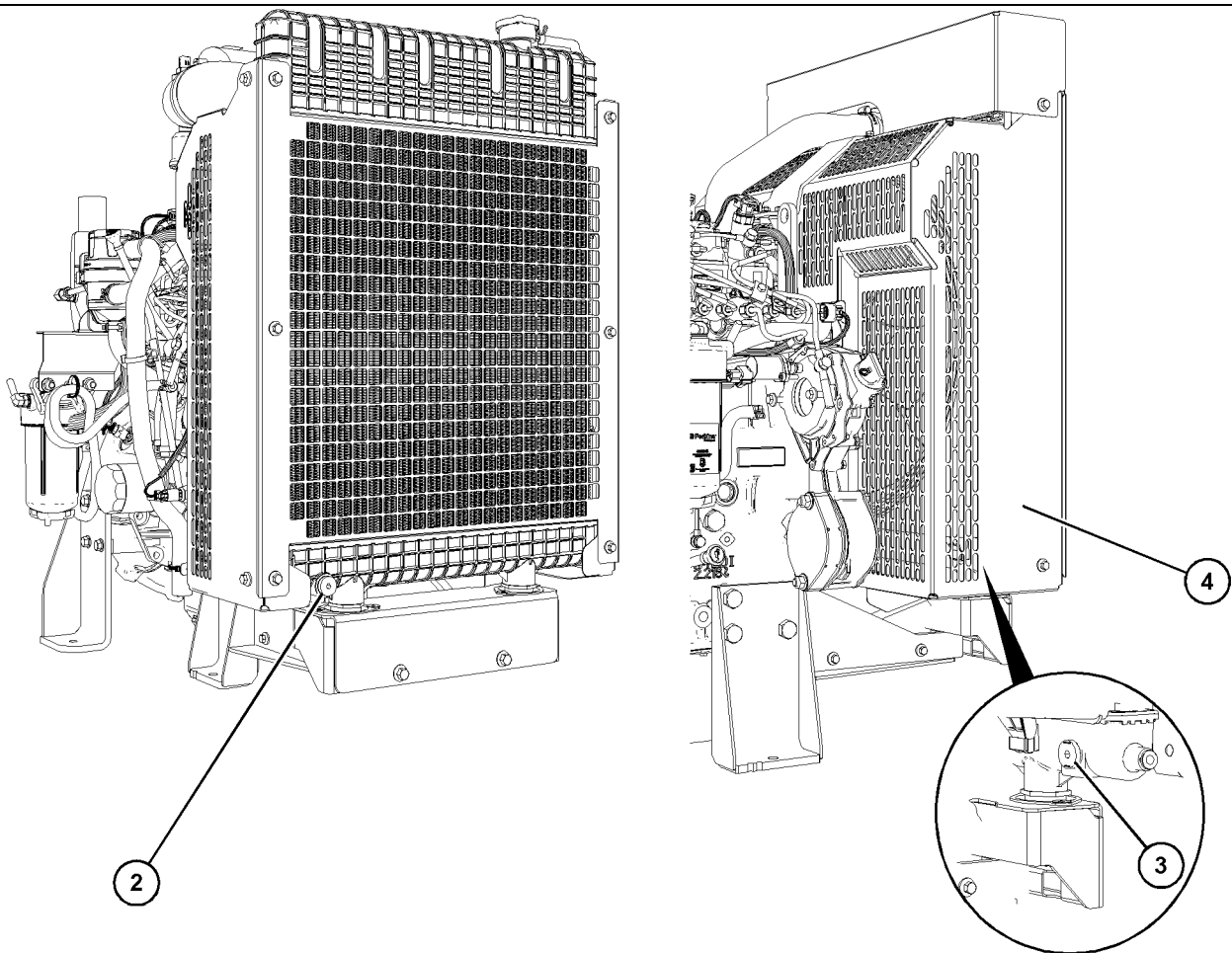

Illustration 66

Typical example

g07522440

(2) Three cylinder OPU radiator drain plug

(3) Four cylinder OPU radiator drain plug

Remove fan guard (4) to get access to the drain plug (3) for the 4 cylinder OPU radiator.

- Tighten drain plug (2) and drain plug (3) to a torque of 4 N·m (35.4 lb in)

Drain Plugs for Factory Installed Radiators

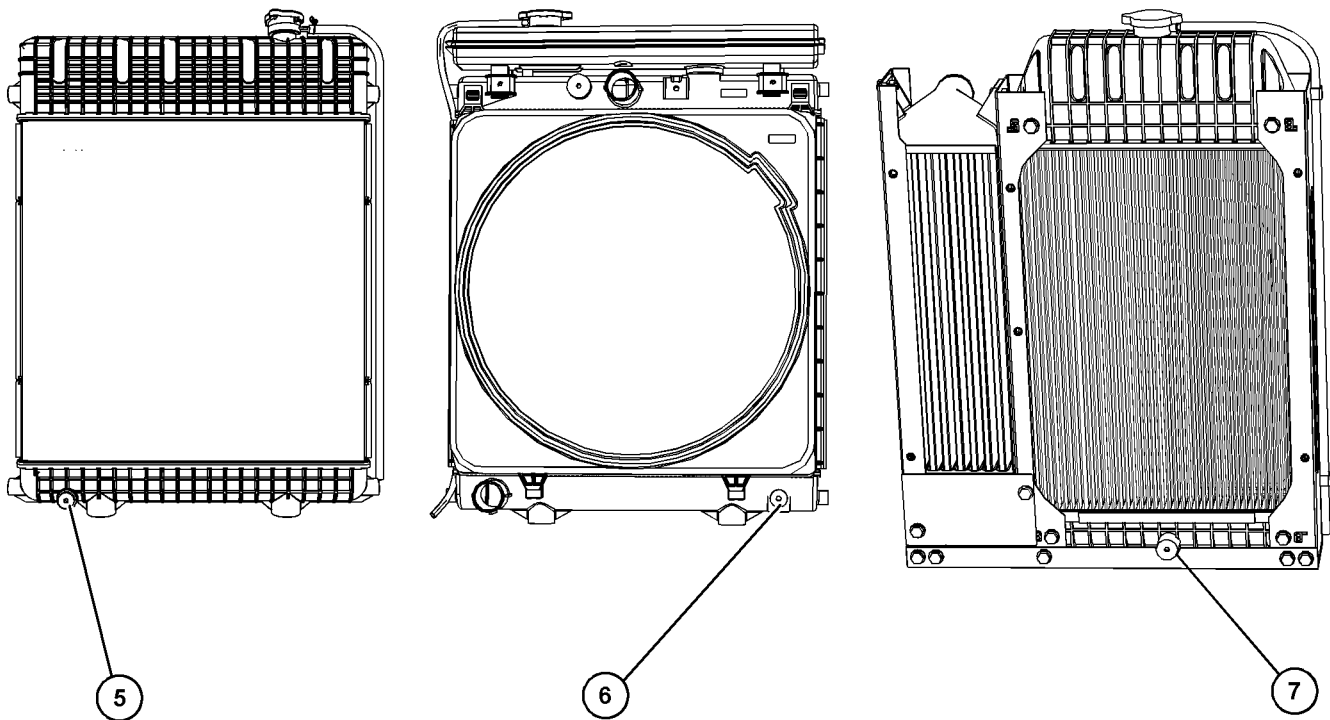

Illustration 67

g07536716

Typical example

(5) Three cylinder engine radiator drain plug

(6) Four cylinder turbocharged engine radiator drain plug

(7) Four cylinder turbocharged aftercooled engine drain plug front of radiator

- Tighten drain plug (5) to a torque of 4 N·m (35.4 lb in)
- Tighten drain plug (6) to a torque of 4 N·m (35.4 lb in)
- Tighten drain plug (7) to a torque of 6 N·m (53. lb in)

Flush

1. Flush the cooling system with clean water to remove any debris.
2. Close the drain valve (if equipped). Clean the drain plugs. Install the drain plugs. Refer to Torque Specifications, SENR3130 for more information on the correct torques.

NOTICE

Do not fill the cooling system faster than 5 L (1.3 US gal) per minute to avoid air locks.

Cooling system air locks may result in engine damage.

3. Fill the cooling system with clean water. Install the cooling system filler cap.
4. Start and run the engine at low idle until the temperature reaches 49 °C to 66 °C (120 °F to 150 °F).

Maintenance Section
Cooling System Coolant (ELC) - Change

5. Stop the engine and allow the engine to cool. Loosen the cooling system filler cap slowly to relieve any pressure. Remove the cooling system filler cap. Open the drain valve (if equipped) or remove the cooling system drain plugs. Allow the water to drain. Flush the cooling system with clean water. Close the drain valve (if equipped). Clean the drain plugs. Install the drain plugs. Refer to Torque Specifications, SENR3130 for more information on the correct torques.

Fill

NOTICE

Do not fill the cooling system faster than 5 L (1.3 US gal) per minute to avoid air locks.

Cooling system air locks may result in engine damage.

1. Fill the cooling system with Extended Life Coolant (ELC). Refer to this Operation and Maintenance Manual, "Refill Capacities and Recommendations" topic (Maintenance Section) for more information on cooling system specifications. Do not install the cooling system filler cap.
2. Start and run the engine at low idle. Increase the engine rpm to high idle. Run the engine at high idle for 1 minute to purge the air from the cavities of the engine block. Stop the engine.
3. Maintain the coolant level at the maximum mark that is correct for your application. For more information, refer to this Operation and Maintenance Manual, "Coolant Level - Check".

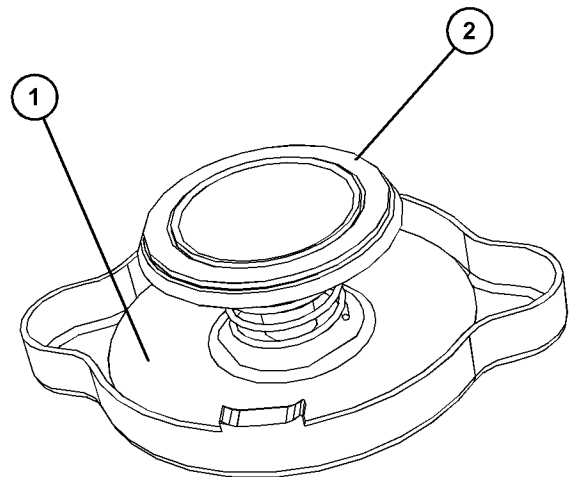

Illustration 68

g06165279

Typical example

4. Clean the cooling system filler cap and check the condition of the filler cap gasket (2). Replace the cooling system filler cap if the filler cap gasket (2) and sealing surface (1) are damaged. If the cooling system filler cap is not damaged, perform a pressure test on the filler cap.

OPU radiators

The cooling system filler cap pressure for OPU radiators on both the three cylinder engine and four cylinder engine is 110 kPa (15.9 psi).

Factory installed radiators

- Radiator cap pressure for both the three cylinder engine and four cylinder engine is 110 kPa (15.9 psi).

If the cooling system filler cap passes the pressure test check, install the filler cap. If required install new cooling system filler cap.

5. Start the engine. Inspect the cooling system for leaks and for proper operating temperature.

i06507208

Cooling System Coolant Extender (ELC) - Add

SMCS Code: 1352-045; 1395-081

Cat ELC (Extended Life Coolant) does not require the frequent additions of any supplemental cooling additives which are associated with the present conventional coolants. The Cat ELC Extender only needs adding once.

NOTICE

Use only Cat Extended Life Coolant (ELC) Extender with Cat ELC.

Do NOT use conventional supplemental coolant additive (SCA) with Cat ELC. Mixing Cat ELC with conventional coolants and/or conventional SCA reduces the Cat ELC service life.

Check the cooling system only when the engine is stopped and cool.

WARNING

Personal injury can result from hot coolant, steam and alkali.

At operating temperature, engine coolant is hot and under pressure. The radiator and all lines to heaters or the engine contain hot coolant or steam. Any contact can cause severe burns.

Remove cooling system pressure cap slowly to relieve pressure only when engine is stopped and cooling system pressure cap is cool enough to touch with your bare hand.

Do not attempt to tighten hose connections when the coolant is hot, the hose can come off causing burns.

Cooling System Coolant Additive contains alkali. Avoid contact with skin and eyes.

NOTICE

Care must be taken to ensure that fluids are contained during performance of inspection, maintenance, testing, adjusting, and repair of the product. Be prepared to collect the fluid with suitable containers before opening any compartment or disassembling any component containing fluids.

Refer to Cat Hand Tools and Shop Supplies for suitable contains use on Cat products.

Dispose of all fluids according to local regulations and mandates.

NOTICE

When any servicing or repair of the engine cooling system is performed, the procedure must be performed with the engine on level ground. This procedure will allow you to check accurately the coolant level. This procedure will also help in avoiding the risk of introducing an air lock into the coolant system.

1. Loosen the cooling system filler cap slowly to relieve pressure. Remove the cooling system filler cap.
2. If necessary, drain enough coolant from the cooling system to add the Cat ELC Extender.
3. Add Cat ELC Extender according to the requirements for your engines cooling system capacity. Refer to the Operation and Maintenance Manual, "Refill Capacities and Recommendations" article for more information.
4. Clean the cooling system filler cap. Inspect the gaskets on the cooling system filler cap. Replace the cooling system filler cap if the gaskets are damaged. Install the cooling system filler cap.

i09670390

Cooling System Coolant Level - Check

SMCS Code: 1395-082

WARNING

Pressurized System: Hot coolant can cause serious burns. To open the cooling system filler cap, stop the engine and wait until the cooling system components are cool. Loosen the cooling system pressure cap slowly in order to relieve the pressure.

Check the coolant level when the engine is stopped and cool.

NOTICE

When any servicing or repair of the engine cooling system is performed, the procedure must be performed with the engine on level ground. This procedure will allow you to check accurately the coolant level. This procedure will also help in avoiding the risk of introducing an air lock into the coolant system.

Remove the cooling system filler cap slowly to relieve the pressure within the cooling system.

For the correct coolant level, refer to the OEM information.

Open Power Unit (OPU) Radiators

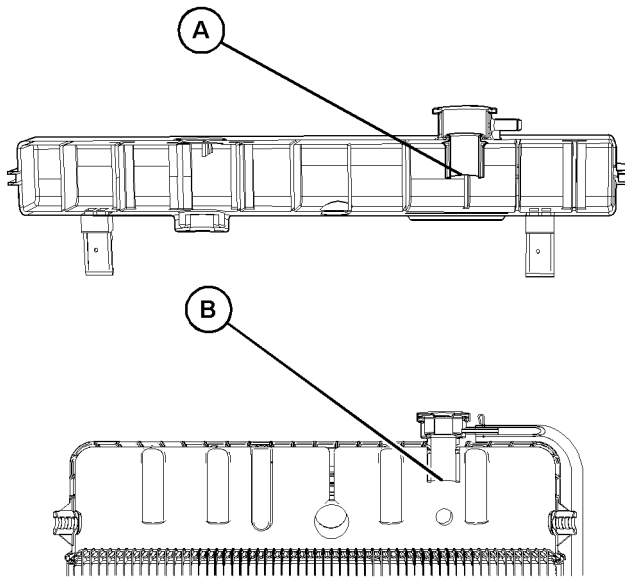

Illustration 69

g07532081

Typical example

- The coolant level (A) is for four cylinder turbocharged OPU radiator.
- The coolant level (B) is for three cylinder turbocharged OPU radiator.

Coolant levels for OPU radiators should be in line with the bottom of the filler neck.

Factory Installed Radiators

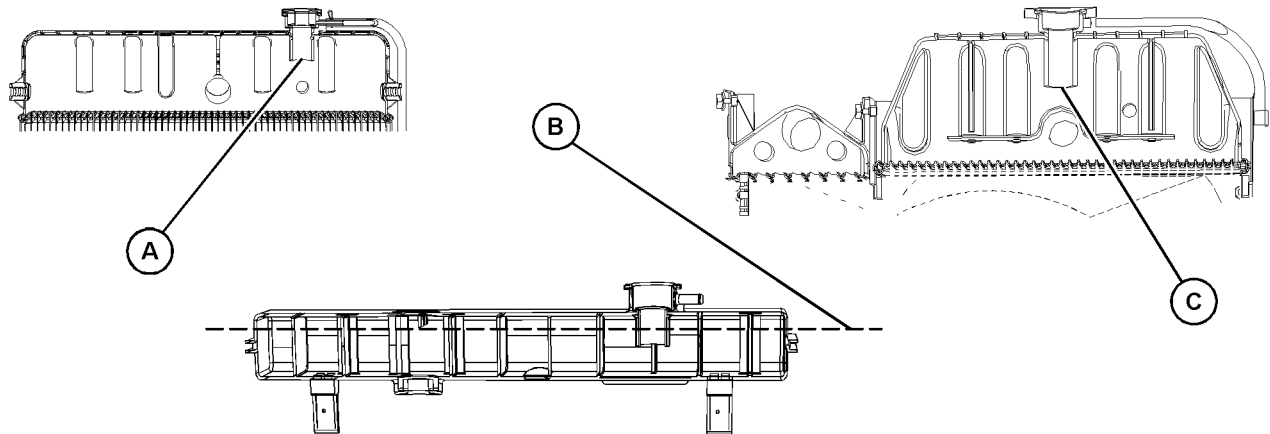

Illustration 70

g07537228

Typical example

- The coolant level (A) is for factory installed radiator with the three cylinder engine.
- The coolant level (B) is for factory installed radiator with the four cylinder turbocharged engine. Once the level has been reached, add 0.5 L (0.13210 US gal) of coolant.
- The coolant level (C) is for factory installed radiator with the four cylinder turbocharged aftercooled engine.

Note: The coolant level (C) for the four cylinder turbocharged engine is different from three cylinder and the four cylinder turbocharged aftercooled engines. The four cylinder turbocharged engine coolant level (B) is 20 mm (0.79 inch) below the top of the radiator neck.

Radiator Cap

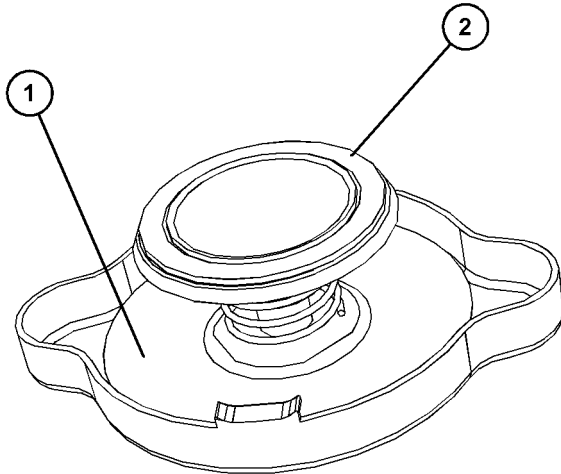

Illustration 71

g06165279

Typical example

Clean the cooling system filler cap and check the condition of the filler cap gasket (1). Replace the cooling system filler cap if the filler cap gasket (1) or the sealing surface (2) are damaged.

The radiator filler cap should be checked at regular intervals to insure that the filler cap relieves pressure correctly.

Cooling system filler cap pressure for factory installed radiators on both the three cylinder engine and four cylinder engine is 110 kPa (15.9 psi).

The cooling system filler cap pressure for OPU radiators on both the three cylinder engine and four cylinder engine is 110 kPa (15.9 psi).

Reinstall the cooling system filler cap when all checks are complete.

i06512656

Cooling System Coolant Sample (Level 1) - Obtain

SMCS Code: 1350-008; 1395-008; 1395-554; 7542

Note: Obtaining a Coolant Sample (Level 1) is optional if the cooling system is filled with Cat ELC (Extended Life Coolant). Cooling systems filled with Cat ELC should have a Coolant Sample (Level 2) that is obtained at the recommended interval as stated in the maintenance interval schedule.

Note: Obtain a Coolant Sample (Level 1) if the cooling system is filled with any other coolant instead of Cat ELC including the following coolants:

- Commercial long life coolants that meet the Caterpillar Engine Coolant Specification -1 (Caterpillar EC-1)
- Cat DEAC (Diesel Engine Antifreeze/Coolant)
- Commercial heavy-duty coolant/antifreeze

Table 16

Recommended Interval		
Type of Coolant	Level 1	Level 2
Cat DEAC	Every 250 service hours	Every year ⁽¹⁾
Conventional heavy duty-coolant		
Commercial coolant that meets the requirements of the Caterpillar EC-1 standard		
Cat ELC or conventional EC-1 coolant	Optional	Every year ⁽¹⁾

⁽¹⁾ The Level 2 Coolant Analysis should be performed sooner if a problem is suspected or identified.

NOTICE

Always use a designated pump for oil sampling, and use a separate designated pump for coolant sampling. Using the same pump for both types of samples may contaminate the samples that are being drawn. This contamination may cause a false analysis and an incorrect interpretation that could lead to concerns by both dealers and customers.

Note: Level 1 results may indicate a need for Level 2 Analysis.

Obtain the sample of the coolant as close as possible to the recommended sampling interval. To receive the full effect of S·O·S analysis, establish a consistent trend of data. To establish a pertinent history of data, perform consistent samplings that are evenly spaced. Supplies for collecting samples can be obtained from your Caterpillar dealer.

Use the following guidelines for proper sampling of the coolant:

- Complete the information on the label for the sampling bottle before you begin to take the samples.
- Keep the unused sampling bottles stored in plastic bags.
- Obtain coolant samples directly from the coolant sample port. You should not obtain the samples from any other location.
- Keep the lids on empty sampling bottles until you are ready to collect the sample.
- Place the sample in the mailing tube immediately after obtaining the sample to avoid contamination.
- Never collect samples from expansion bottles.
- Never collect samples from the drain for a system.

Submit the sample for Level 1 analysis.

For additional information about coolant analysis, see this Operation and Maintenance Manual, "Refill Capacities and Recommendations" or consult your Cat dealer.

i06512661

Cooling System Coolant Sample (Level 2) - Obtain

SMCS Code: 1350-008; 1395-554; 1395-008; 7542

NOTICE

Always use a designated pump for oil sampling, and use a separate designated pump for coolant sampling. Using the same pump for both types of samples may contaminate the samples that are being drawn. This contaminate may cause a false analysis and an incorrect interpretation that could lead to concerns by both dealers and customers.

NOTICE

Care must be taken to ensure that fluids are contained during performance of inspection, maintenance, testing, adjusting, and repair of the product. Be prepared to collect the fluid with suitable containers before opening any compartment or disassembling any component containing fluids.

Refer to Special Publication, NENG2500, "Cat Dealer Service Tool Catalog" or refer to Special Publication, PECJ0003, "Cat Shop Supplies and Tools Catalog" for tools and supplies suitable to collect and contain fluids on Cat products.

Dispose of all fluids according to local regulations and mandates.

Refer to Operation and Maintenance Manual, "Cooling System Coolant Sample (Level 1) - Obtain" for the guidelines for proper sampling of the coolant.

Submit the sample for Level 2 analysis.

For additional information about coolant analysis, see Special Publication, SEBU6251, "Caterpillar Commercial Diesel Engines Fluids Recommendations" or consult your Cat dealer.

i06511778

Cooling System Water Temperature Regulator - Replace

SMCS Code: 1355-510

Replace the water temperature regulator before the water temperature regulator fails. This replacement is a recommended preventive maintenance practice. Replacing the water temperature regulator reduces the chances for unscheduled downtime.

A water temperature regulator that fails in a partially opened position can cause overheating or overcooling of the engine.

A water temperature regulator that fails in the closed position can cause excessive overheating. Excessive overheating could result in cracking of the cylinder head or piston seizure problems.

A water temperature regulator that fails in the open position will cause the engine operating temperature to be too low during partial load operation. Low engine operating temperatures during partial loads could cause an excessive carbon buildup inside the cylinders. This excessive carbon buildup could result in an accelerated wear of the piston rings and wear of the cylinder liner.

Maintenance Section
Crankcase Breather (Canister) - Replace

NOTICE

Failure to replace your water temperature regulator on a regularly scheduled basis could cause severe engine damage.

Cat engines incorporate a shunt bypass design cooling system and require operating the engine with a water temperature regulator installed.

If the water temperature regulator is installed incorrectly, the engine may overheat, causing cylinder head damage. Ensure that the new water temperature regulator is installed in the original position. Ensure that the water temperature regulator vent hole is open.

Do not use liquid gasket material on the gasket or cylinder head surface.

Refer to Disassembly and Assembly, "Water Temperature Regulator - Remove and Install". Consult your Cat dealer for more information.

Note: If only the water temperature regulators are replaced, drain the coolant from the cooling system to a level that is below the water temperature regulator housing.

i07988065

Crankcase Breather (Canister) - Replace

SMCS Code: 1317-510

WARNING

Hot oil and hot components can cause personal injury. Do not allow hot oil or hot components to contact the skin.

NOTICE

Ensure that the engine is stopped before any servicing or repair is performed.

NOTICE

Care must be taken to ensure that fluids are contained during performance of inspection, maintenance, testing, adjusting and repair of the product. Be prepared to collect the fluid with suitable containers before opening any compartment or disassembling any component containing fluids.

Dispose of all fluids according to local regulations and mandates.

The crankcase breather plays a major role in keeping your engine emissions compliant.

- The filter element within the crankcase breather must be serviced at the prescribed service interval.
- The correct filter element must be installed before the engine is operated.
- The installation of the filter element is critical to the correct operation of the engine.
- The quality of the filter element that is installed is very important, Caterpillar recommend using genuine Caterpillar filters.
- The filter element protects the engine from excessive quantities of oil from entering the induction system. The filter element also protects the engine aftertreatment system.

Note: Excessive quantities of oil that enter the induction system of the engine can rapidly increase the engine speed without control.

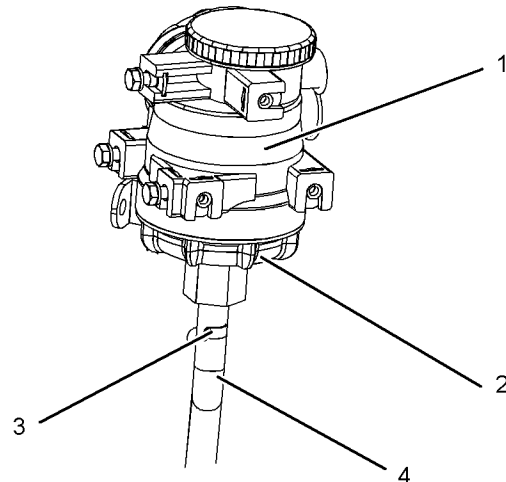

Illustration 72

g03331718

Typical example

1. Ensure that dirt cannot enter the breather assembly. Ensure that the outside body of the breather assembly is clean and free from damage. Place a container under the breather assembly.
2. Make temporary marks on hose (4) to identify the correct orientation for installation purposes.

Note: A one-way valve is installed into the hose, incorrectly installing the hose can cause catastrophic engine failure.

3. Remove clip (3) and remove hose (4) from cap (2). Remove cap (2) from the main body (1).

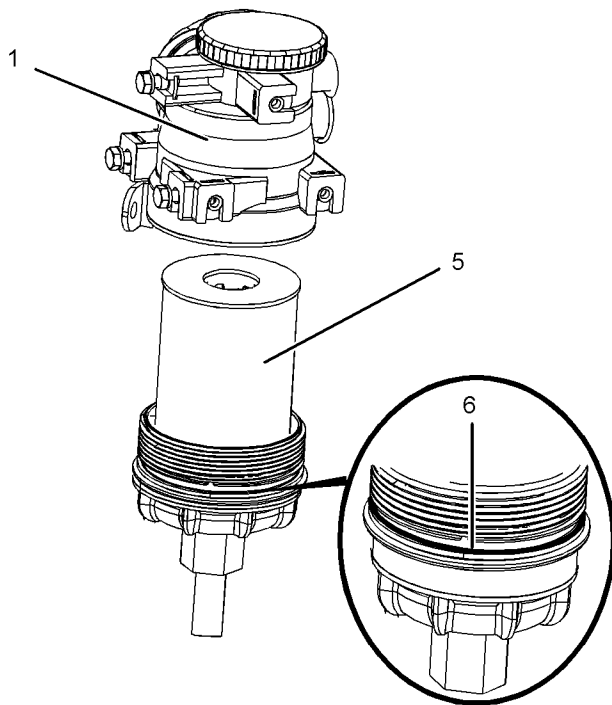

Illustration 73

g03331704

Typical example

4. Remove filter element (5) and remove O-ring seal (6) and discard.

Note: Ensure that all parts are clean and free from dirt and damage.

5. Apply clean engine oil to new O-ring seal (6). Install the O-ring seal onto cap (2).
6. Install a new filter element (5) into cap (2).
7. Install cap assembly into the main body (1). Tighten the cap assembly to 10 N·m (7 lb ft).

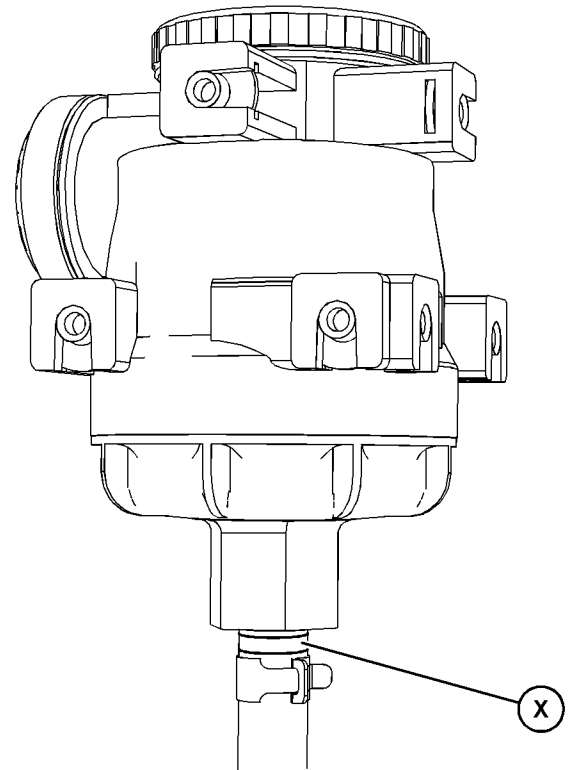

Illustration 74

g06477300

8. Install hose (4) and clip (3). Ensure that the hose is correctly orientated.

If a new hose is being installed, the end of the hose with the white band in Position (X) must be attached to the breather canister. Refer to Illustration 74 for the correct positioning.

Note: Incorrectly installing the hose can cause catastrophic engine failure.

9. Remove the container and clean away any spilt fluid.

i09670446

Crankcase Breather (Canister) - Replace (Open Crankcase Breather)

SMCS Code: 1317-510

WARNING

Hot oil and hot components can cause personal injury. Do not allow hot oil or hot components to contact the skin.

Maintenance Section
Open Crankcase Breather

NOTICE

Ensure that the engine is stopped before any servicing or repair is performed.

NOTICE

Care must be taken to ensure that fluids are contained during performance of inspection, maintenance, testing, adjusting and repair of the product. Be prepared to collect the fluid with suitable containers before opening any compartment or disassembling any component containing fluids.

Dispose of all fluids according to local regulations and mandates.

The crankcase breather plays a major role in keeping your engine emissions compliant.

- The filter element within the crankcase breather must be serviced at the prescribed service interval.
- The correct filter element must be installed before the engine is operated.
- The installation of the filter element is critical to the correct operation of the engine.
- The quality of the filter element that is installed is very important, Caterpillar recommend using genuine Caterpillar filters.

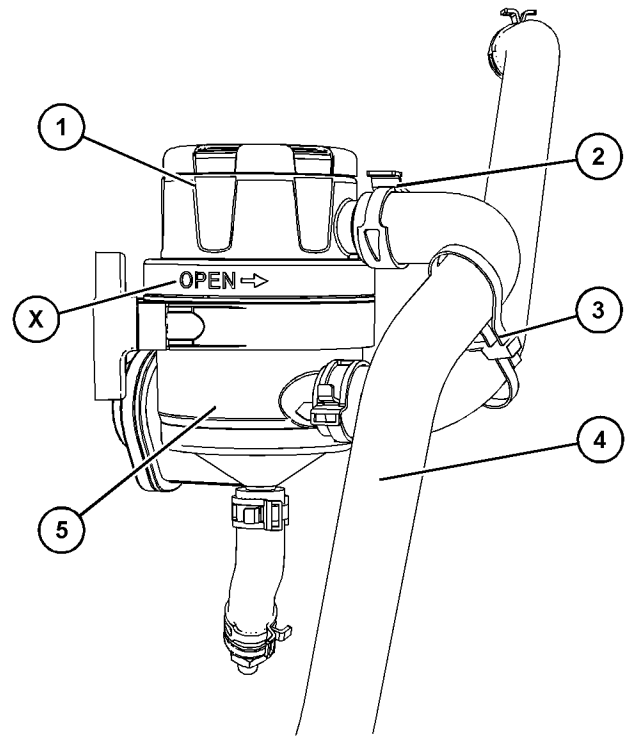

Illustration 75

g06773063

Typical example

1. Ensure that dirt cannot enter the breather assembly. Ensure that the outside body of the breather assembly is clean and free from damage. Place a container under the breather assembly.
2. Reposition hose clamp (2) to allow hose (4) to be disconnected. Discard hose clamp (2).

Note: The orientation of the breather canister assembly for 3 cylinder engines is different to the 4 cylinder engines.

3. If necessary, cut cable strap (3).
4. Disconnect hose (4) from cap (1).
5. Rotate cap (1) in a counter clockwise direction, as shown in Position (X) in Illustration 75 . Remove cap (1) from the main body (5).

i07819515

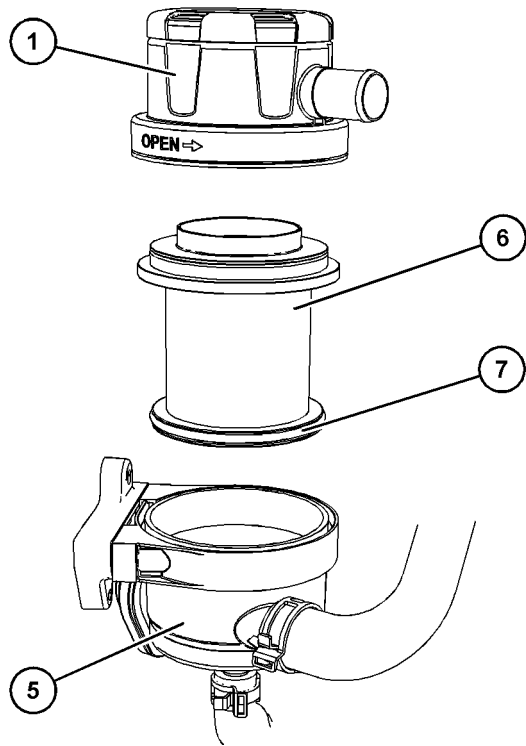

Illustration 76

g06773085

Typical example

6. Remove breather filter element (6) from main body (5). Discard the filter element.

Note: Ensure that all parts are clean and free from dirt and damage.

7. Apply clean engine oil to lower filter seal (7).

8. Install filter element (6) into main body (5).

Note: Ensure that the filter element is pushed down in the main body. The top seal should sit uniformly across the circumference of the main body.

9. Position cap assembly onto main body (5). Tighten the cap.

Note: Ensure that the top cap is correctly engaged to the main body.

10. Install new hose clamp (2) onto hose (4).

11. Connect hose (4) to cap (1). Secure the hose in position with hose clamp (2).

12. If necessary, install new cable strap (3)

13. Remove the container and clean away any spilt fluid.

Engine - Clean

SMCS Code: 1000-070

WARNING

Personal injury or death can result from high voltage.

Moisture can create paths of electrical conductivity.

Make sure that the electrical system is OFF. Lock out the starting controls and tag the controls "DO NOT OPERATE" .

NOTICE

Accumulated grease and oil on an engine is a fire hazard. Keep the engine clean. Remove debris and fluid spills whenever a significant quantity accumulates on the engine.

Periodic cleaning of the engine is recommended. Steam cleaning the engine will remove accumulated oil and grease. A clean engine provides the following benefits:

- Easy detection of fluid leaks
- Maximum heat transfer characteristics
- Ease of maintenance

Note: Caution must be used to prevent electrical components from being damaged by excessive water when the engine is cleaned. Pressure washers and steam cleaners should not be directed at any electrical connectors or the junction of cables into the rear of the connectors. Avoid electrical components such as the alternator, the starter, and the ECM. Protect the fuel injection pump from fluids to wash the engine.

Ensure that care is taken that the safety labels, emission label, and all other information labels are not removed during engine cleaning.

Aftertreatment

During the engine cleaning process, ensure that water or cleaning fluids cannot enter the aftertreatment system. If cleaning fluids enters the aftertreatment system, damage could occur.

i09670415

Engine Air Cleaner Element - Replace

SMCS Code: 1051-510; 1054-510

NOTICE

Never run the engine without an air cleaner element installed. Never run the engine with a damaged air cleaner element. Do not use air cleaner elements with damaged pleats, gaskets or seals. Dirt entering the engine causes premature wear and damage to engine components. Air cleaner elements help to prevent airborne debris from entering the air inlet.

NOTICE

Never service the air cleaner element with the engine running since this will allow dirt to enter the engine.

Servicing the Air Cleaner Elements

Note: The engine air cleaner may not have been supplied by Caterpillar. Refer to the Original Equipment Manufacturer (OEM) information for further details on the engine air cleaner maintenance.

If the air cleaner element becomes plugged, the air can split the material of the air cleaner element. Unfiltered air will drastically accelerate internal engine wear.

- Check the precleaner (if equipped) and the dust bowl daily for accumulation of dirt and debris. Remove any dirt and debris, as needed.
- Operating in dirty conditions may require more frequent service of the air cleaner element.
- The air cleaner element should be replaced at least one time per year.

Replace the dirty air cleaner elements with clean air cleaner elements. Before installation, the new air cleaner elements should be thoroughly checked for tears and/or holes in the filter material. Inspect the gasket or the seal of the air cleaner element for damage. Maintain a supply of suitable air cleaner elements for replacement purposes.

Some application can have dual elements. The dual air cleaner contains a primary air cleaner element and a secondary air cleaner element. Both element must be replaced at the same time.

Do not replace the air cleaner filter elements in a dirty environment, as dirt can enter the air system when the elements are removed.

Air Cleaners type 1

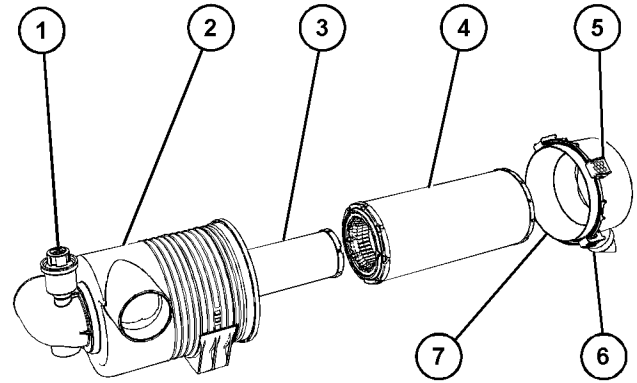

Illustration 77

g07537605

Typical example

- (1) Air Service Indicator
- (2) Air Cleaner Body
- (3) Secondary Air Filter Element
- (4) Primary Air Filter Element
- (5) Clips
- (6) Vacuum Valve
- (7) End Cover

1. Ensure that the outer body of the air cleaner to be serviced is clean and free from dirt.
2. Release clips (5) and remove end cover (7) from air cleaner body (2). If necessary, clean end cover and ensure that the valve (6) is clean and free from dirt. Check the valve (6) for wear or damage, replace if necessary.
3. Remove primary air filter element (4) and, remove the secondary air filter element (3). Discard all old air filter elements.
4. Install new secondary air filter element (3) and install new primary air filter element (4).
5. Install end cover (7) to air cleaner body (2) and secure end cover clips (5). If necessary, reset the air service indicator (1), refer to this Operation and Maintenance Manual, Engine Air Cleaner Service Indicator - Inspect for more information.

Air Cleaners type 2

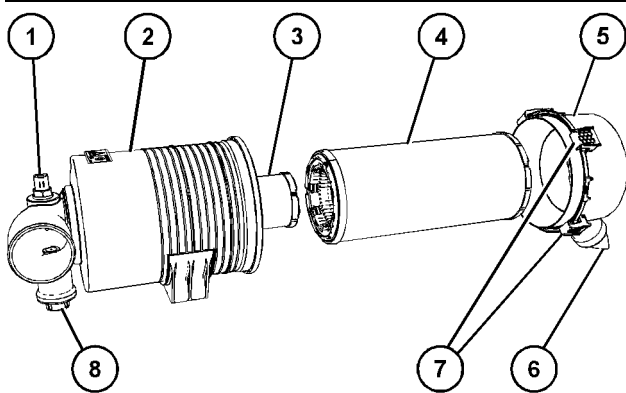

Illustration 78

g07531939

Typical example

- (1) Inlet Air temperature sensor
- (2) Air Cleaner Body
- (3) Secondary Air Filter Element
- (4) Primary Air Filter Element
- (5) End Cover
- (6) Vacuum Valve
- (7) Clips
- (8) Air Service Indicator

1. Ensure that the outer body of the air cleaner to be serviced is clean and free from dirt.
2. Release clips (7) and remove end cover (5) from air cleaner body (2). If necessary, clean end cover and ensure that the valve (6) is clean and free from dirt. Check the valve (6) for wear or damage, replace if necessary.
3. Remove primary air filter element (4) and, remove the secondary air filter element (3). Discard all old air filter elements.
4. Install new secondary air filter element (3) and install new primary air filter element (4).
5. Install end cover (5) to air cleaner body (2) and secure end cover clips (7). If necessary, reset the air service indicator (8), refer to this Operation and Maintenance Manual, Engine Air Cleaner Service Indicator - Inspect for more information.

i09119853

Engine Air Cleaner Service Indicator - Inspect

SMCS Code: 7452-040

Some engines may be equipped with a different service indicator.

Some engines are equipped with a differential gauge for inlet air pressure. The differential gauge for inlet air pressure displays the difference in the pressure that is measured before the air cleaner element and the pressure that is measured after the air cleaner element. As the air cleaner element becomes dirty, the pressure differential rises. If your engine is equipped with a different type of service indicator, follow the OEM recommendations to service the air cleaner service indicator.

Type 1 Service Indicator

The service indicator may be mounted on the air cleaner element or in a remote location.

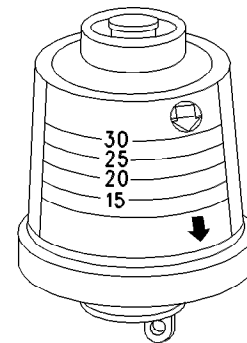

Illustration 79

g00103777

Typical example of type 1 service indicator

Observe the service indicator. The air cleaner element should be cleaned or the air cleaner element should be replaced when one of the following conditions occurs:

- The yellow diaphragm enters the red zone.
- The red piston locks in the visible position.

Type 2 Service Indicator

The service indicator is installed on the air cleaner element. The service indicator is to be tightened by hand, ensuring the o ring seal is in place.

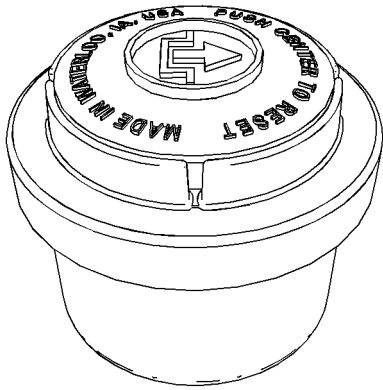

Illustration 80

g07079288

Typical example of type 2 service indicator

Observe the service indicator. The air cleaner element should be cleaned or the air cleaner element should be replaced when one of the following conditions occurs:

- The yellow diaphragm enters the red zone.
- The red piston locks in the visible position.

Test the Service Indicator

Service indicators are important instruments.

- Check for ease of resetting. The service indicator should reset in fewer than three pushes.
- Check the movement of the yellow core when the engine is accelerated to the engine rated speed. The yellow core should latch at the greatest vacuum that is attained.

If the service indicator does not reset easily, or if the yellow core does not latch at the greatest vacuum, the service indicator should be replaced. If the new service indicator will not reset, the hole for the service indicator may be restricted.

The service indicator may need to be replaced frequently in environments that are severely dusty.

i07988074

Engine Air Precleaner - Check/Clean

SMCS Code: 1055-535; 1055-070

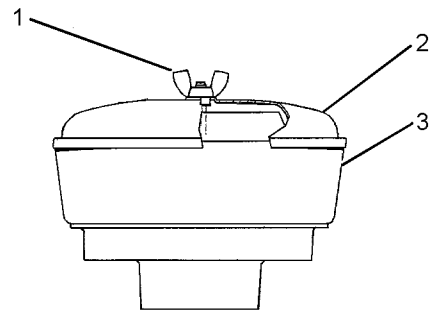

Illustration 81

g01453058

Typical engine air pre-cleaner

- (1) Wing nut
- (2) Cover
- (3) Body

Remove wing nut (1) and cover (2). Check for an accumulation of dirt and debris in body (3). Clean the body, if necessary.

After cleaning the pre-cleaner, install cover (2) and wing nut (1).

Note: When the engine is operated in dusty conditions, more frequent cleaning is required.

Do not tap or strike the air cleaner element.

i02456872

Engine Mounts - Inspect

SMCS Code: 1152-040

Inspect the engine mounts for deterioration and for proper bolt torque. Engine vibration can be caused by the following conditions:

- Improper mounting of the engine
- Deterioration of the engine mounts

Any engine mount that shows deterioration should be replaced. Refer to Special Publication, SENR3130, "Torque Specifications" for the recommended torques. Refer to the OEM recommendations for more information.

i05164949

i08397634

Engine Oil Level - Check

SMCS Code: 1348-535-FLV

⚠ WARNING

Hot oil and hot components can cause personal injury. Do not allow hot oil or hot components to contact the skin.

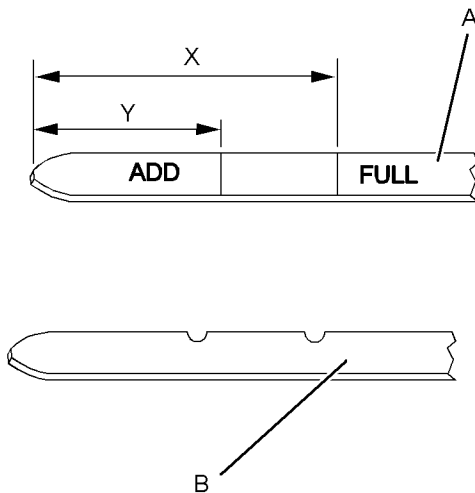

Illustration 82

g03317856

(Y) "ADD" mark. (X) "FULL" mark.

(A) Original oil level gauge

(B) Alternative oil level gauge

NOTICE

Perform this maintenance with the engine stopped.

Note: Oil gauge (A) or oil gauge (B) may be installed in the engine.

1. Maintain the oil level between "ADD" mark (Y) and "FULL" mark (X) on oil level gauge (1). Do not fill the crankcase above "FULL" mark (X).

NOTICE

Operating your engine when the oil level is above the "FULL" mark could cause your crankshaft to dip into the oil. The air bubbles created from the crankshaft dipping into the oil reduces the oil's lubricating characteristics and could result in the loss of power.

2. Remove the oil filler cap and add oil, if necessary. Clean the oil filler cap. Install the oil filler cap.

Engine Oil Sample - Obtain

SMCS Code: 1000-008; 1348-554-SM; 7542-554-SM; 7542-554-OC

In addition to a good preventive maintenance program, Caterpillar recommends using S·O·S oil analysis at regularly scheduled intervals. S·O·S oil analysis provides infrared analysis, which is required for determining nitration and oxidation levels.

Obtain the Sample and the Analysis

⚠ WARNING

Hot oil and hot components can cause personal injury. Do not allow hot oil or hot components to contact the skin.

Before you take the oil sample, complete the Label, PEEP5031 for identification of the sample. To help obtain the most accurate analysis, provide the following information:

- Engine model
- Service hours on the engine
- The number of hours that have accumulated since the last oil change
- The amount of oil that has been added since the last oil change

To ensure that the sample is representative of the oil in the crankcase, obtain a warm, mixed oil sample.

To avoid contamination of the oil samples, the tools and the supplies that are used for obtaining oil samples must be clean.

Caterpillar recommends using the sampling valve to obtain oil samples. The quality and the consistency of the samples are better when the sampling valve is used. The location of the sampling valve allows oil that is flowing under pressure to be obtained during normal engine operation.

The 169-8373 Fluid Sampling Bottle is recommended for use with the sampling valve. The fluid sampling bottle includes the parts that are needed for obtaining oil samples. Instructions are also provided.

NOTICE

Always use a designated pump for oil sampling, and use a separate designated pump for coolant sampling. Using the same pump for both types of samples may contaminate the samples that are being drawn. This contaminate may cause a false analysis and an incorrect interpretation that could lead to concerns by both dealers and customers.

If the engine is not equipped with a sampling valve, use the 1U-5718 Vacuum Pump. The pump is designed to accept sampling bottles. Disposable tubing must be attached to the pump for insertion into the sump.

For instructions, see Special Publication, PEGJ0047, "How To Take A Good S·O·S Oil Sample". Consult your Cat dealer for complete information and assistance in establishing an S·O·S program for your engine.

i08455102

Engine Oil and Filter - Change

SMCS Code: 1318-510; 1348-044

 **WARNING**

Hot oil and hot components can cause personal injury. Do not allow hot oil or hot components to contact the skin.

NOTICE

Care must be taken to ensure that fluids are contained during performance of inspection, maintenance, testing, adjusting and repair of the product. Be prepared to collect the fluid with suitable containers before opening any compartment or disassembling any component containing fluids.

Dispose of all fluids according to local regulations and mandates.

NOTICE

Keep all parts clean from contaminants.

Contaminants may cause rapid wear and shortened component life.

Do not drain the oil when the engine is cold. As the oil cools, suspended waste particles settle on the bottom of the oil pan. The waste particles are not removed with the draining cold oil. Drain the crankcase with the engine stopped. Drain the crankcase with the oil warm. This draining method allows the waste particles that are suspended in the oil to be drained correctly.

Failure to follow this recommended procedure will cause the waste particles to be recirculated through the engine lubrication system with the new oil.

Oil and Filter Change Intervals

The standard engine oil and filter change period is 500 hours. There are several other factors that can alter the standard engine oil and filter change of 500 hours.

- If the engine is using engine oil analysis to determine oil and filter change period.
- The engine is working in a severe service environment/Load Factor
- Infrequent operation of the engine

Refer to this Operation and Maintenance Manual, "Severe Service Application" for more information on reducing the engine oil and filter change period. For severe service applications the recommended oil and filter change period is 250 hours.

If the engine is operated in severe service conditions, Caterpillar recommends the use of engine oil sampling. Refer to this Operation and Maintenance Manual, Fluid Recommendations, Engine Lubricating Oil and see section Oil Analysis for more information.

If the engine is operated infrequently less than 500 hours in a 12-month period, then the engine oil and filter change should be conducted yearly.

Drain the Engine Oil

After the engine has been run at the normal operating temperature, stop the engine. Use one of the following methods to drain the engine crankcase oil:

- If the engine is equipped with a drain valve, turn the drain valve knob counterclockwise to drain the oil. After the oil has drained, turn the drain valve knob clockwise to close the drain valve.
- If the engine is not equipped with a drain valve, remove the oil drain plug to allow the oil to drain. After the oil has drained, the oil drain plug should be cleaned and installed.

Replace the Oil Filter

NOTICE

Caterpillar oil filters are built to Caterpillar specifications. Use of an oil filter not recommended by Caterpillar could result in severe engine damage to the engine bearings, crankshaft, etc., as a result of the larger waste particles from unfiltered oil entering the engine lubricating system. Only use oil filters recommended by Caterpillar.

1. Remove the oil filter (3) with a 1U-8760 Chain Wrench.

Note: The following actions can be carried out as part of the preventive maintenance program.

2. Cut the oil filter open with a 175-7546 Oil Filter Cutter Gp. Break apart the pleats and inspect the oil filter for metal debris. An excessive amount of metal debris in the oil filter may indicate early wear or a pending failure.

Use a magnet to differentiate between the ferrous metals and the nonferrous metals that are found in the oil filter element. Ferrous metals may indicate wear on the steel and cast iron parts of the engine.

Nonferrous metals may indicate wear on the aluminum parts, brass parts, or bronze parts of the engine. Parts that may be affected include the following items: main bearings, rod bearings, turbocharger bearings, and cylinder heads.

Due to normal wear and friction, it is not uncommon to find small amounts of debris in the oil filter. Consult your Cat dealer to arrange for a further analysis if an excessive amount of debris is found in the oil filter.

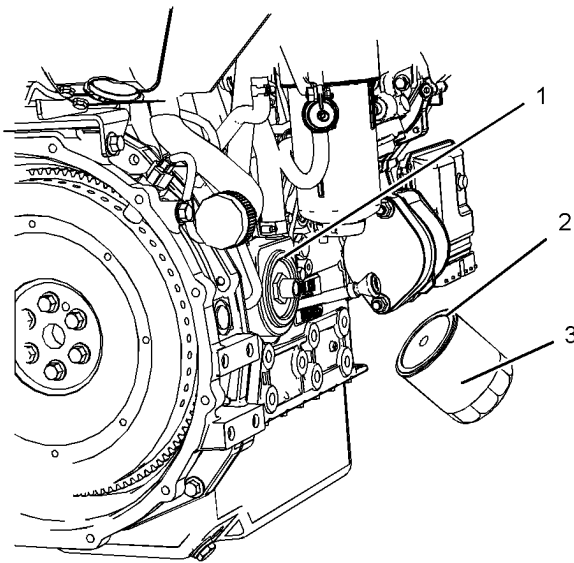

Illustration 83

g03890458

3. Clean the sealing surface of the cylinder block (1).
4. Apply clean engine oil to the new oil filter seal (2).

NOTICE

Do not fill the oil filters with oil before installing them. This oil would not be filtered and could be contaminated. Contaminated oil can cause accelerated wear to engine components or engine damage.

5. Install the oil filter (3). Tighten the oil filter until the oil filter seal contacts the cylinder block or the oil cooler. Tighten the oil filter by hand according to the instructions that are shown on the oil filter. Do not overtighten the oil filter.

Fill the Engine Crankcase

1. Remove the oil filler cap. Refer to this Operation and Maintenance Manual, "Refill Capacities and Recommendations" for more information on lubricant specifications. Fill the crankcase with the correct amount of oil. Refer to this Operation and Maintenance Manual, "Refill Capacities" for more information on refill capacities.

NOTICE

If equipped with an auxiliary oil filter system or a remote oil filter system, follow the OEM or filter manufacturer's recommendations. Under filling or overfilling the crankcase with oil can cause engine damage.

NOTICE

To prevent crankshaft bearing damage, crank the engine with the fuel OFF. This will fill the oil filters before starting the engine. Do not crank the engine for more than 30 seconds.

2. Start the engine and run the engine at "LOW IDLE" for 2 minutes. Perform this procedure to ensure that the lubrication system has oil and that the oil filters are filled. Inspect the oil filter for oil leaks.
3. Stop the engine and allow the oil to drain back to the sump for a minimum of 10 minutes.

Maintenance Section
Engine Valve Lash - Check

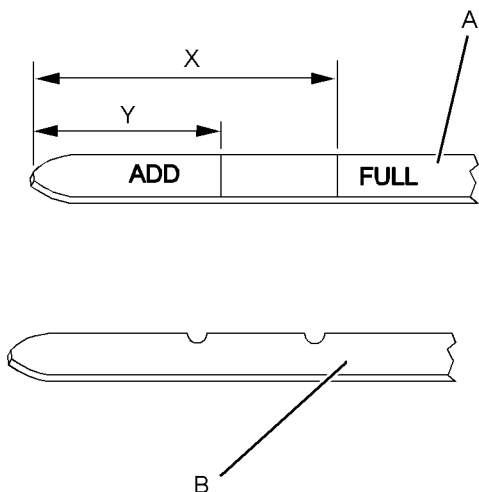

Illustration 84

g03317856

- (Y) ADD Mark
(X) FULL Mark
(A) Original oil level gauge
(B) Alternative oil level gauge

4. Remove the oil level gauge to check the oil level. Maintain the oil level between the "ADD" and "FULL" marks on the oil level gauge.

i06299296

Engine Valve Lash - Check

SMCS Code: 1105-535

WARNING

Ensure that the engine cannot be started while this maintenance is being performed. To help prevent possible injury, do not use the starting motor to turn the flywheel.

Hot engine components can cause burns. Allow additional time for the engine to cool before measuring/adjusting valve lash clearance.

NOTICE

Only qualified service personnel should perform this maintenance.

Operation of the engines with incorrect valve lash can reduce engine efficiency, and also reduce engine component life.

This maintenance is recommended as part of a lubrication and preventive maintenance schedule in order to help provide maximum engine life. The maintenance for the valve lash is important in order to keep the engine compliant.

Ensure that the engine is stopped before measuring the valve lash. The engine valve lash can be inspected and adjusted when the engine is cold.

- Inlet valve _____ 0.20 mm (0.8 inch)
- Exhaust valve _____ 0.20 mm (0.8 inch)

Refer to Systems Operation, Testing and Adjusting, "Engine Valve Lash - Inspect/Adjust" for the correct sequence of adjustment.

i09672814

Fan Clearance - Check

SMCS Code: 1356; 1359; 1360

Open Power Unit (OPU) Radiators

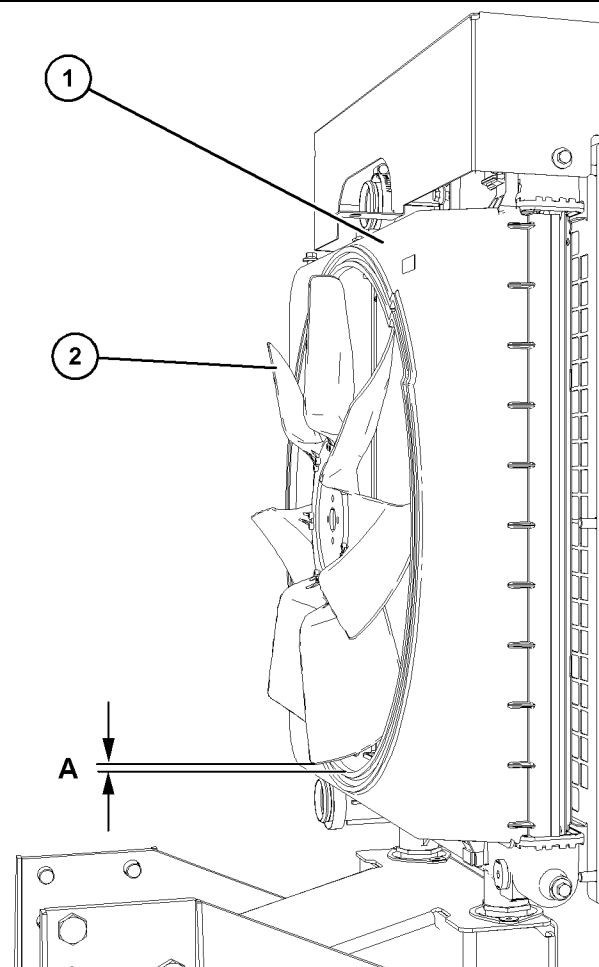

Illustration 85

g07532890

Typical example

Ensure that the engine is stopped. Ensure that the battery disconnect switch is in the OFF position. Ensure that the cooling system is full.

The clearance between the cover (1) and the fan (2) will require checking. The gap between the edge of the cover and the tip of the fan blade (A) must be checked in four equally spaced positions.

The clearance is to be:

- For the three cylinder engine, (A) equals 8 mm (0.315 inch)
- For the four cylinder engine, (A) equals 8.5 mm (0.335 inch)

Factory Installed Radiators

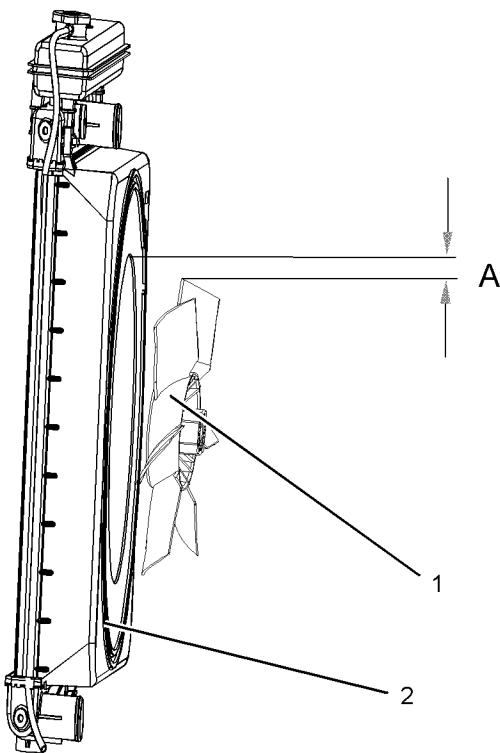

Illustration 86

g03309719

Typical example

Ensure that the engine is stopped. Ensure that the battery disconnect switch is in the OFF position. Ensure that the cooling system is full.

The clearance between the cover (2) and the fan (1) will require checking. The gap between the edge of the cover and the tip of the fan blade (A) must be checked in four equally spaced positions.

Note: The cover is not adjustable.

Three Cylinder

- (A) equals 5 mm (0.19685 inch) for the three cylinder engine

Four Cylinder Turbocharged

- (A) equals 10 mm (0.39370 inch) for the turbocharged engine.

Four Cylinder Turbocharged Aftercooled

- (A) equals 8 mm (0.31496 inch) for the turbocharged aftercooled engine.

i08197312

Fuel System - Prime

SMCS Code: 1258-548

Note: Refer to Systems Operation, Testing, and Adjusting, "Cleanliness of Fuel System Components" for detailed information on the standards of cleanliness that must be observed during ALL work on the fuel system.

Ensure that all adjustments and repairs are performed by authorized personnel that have had the correct training.

NOTICE

Do not crank the engine continuously for more than 30 seconds. Allow the starting motor to cool for two minutes before cranking the engine again.

If air enters the fuel system, the air must be purged from the fuel system before the engine can be started. Air can enter the fuel system when the following events occur:

- The fuel tank is empty or the fuel tank has been partially drained.
- The low-pressure fuel lines are disconnected.
- A leak exists in the low-pressure fuel system.
- The fuel filter has been replaced.

Use the following procedures to remove air from the fuel system:

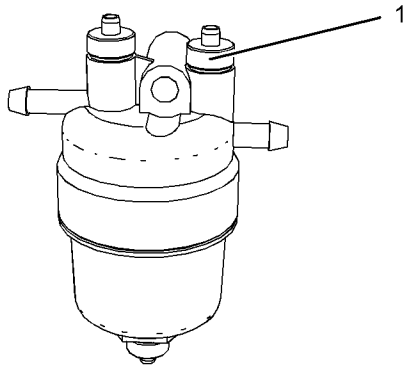

Illustration 87

g03891128

Typical example

1. Ensure that the fuel tank is full and any fuel valve (if equipped) is in the "ON" position.
2. If the application has a gravity feed fuel system, then loosen vent screw (1) and allow fuel to flow. When fuel free from air comes from the vent screw, tighten the vent screw (1) by hand. If the fuel system is not a gravity feed fuel system, then go to Step 3.

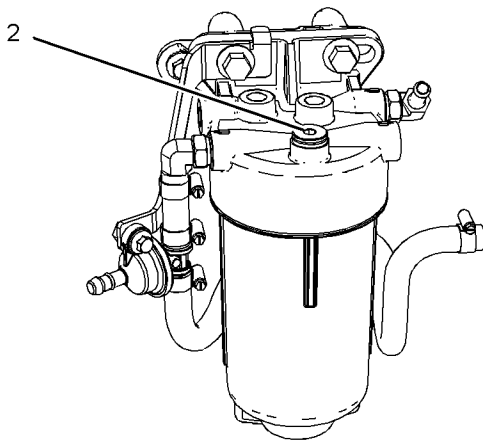

Illustration 88

g03891159

Typical example

3. Loosen the vent screw (2) on the secondary fuel filter. Turn the keyswitch to the "RUN" position.

4. The keyswitch will allow the electric priming pump to operate. When fuel free from air comes from the vent screw (2), tighten the vent screw to a torque of 24 N·m (212. lb in). Then, operate the electric priming pump for 2 minutes.
5. Turn the keyswitch to the "OFF" position. The fuel system will now be primed and the engine should be able to start.
6. Operate the engine starter and crank the engine. After the engine has started, operate the engine at low idle for a minimum of 5 minutes. For constant speed engines do not apply load for 5 minutes.

Note: Operating the engine for this period will help ensure that the fuel system is free of air. **DO NOT loosen the high-pressure fuel lines to purge air from the fuel system. This procedure is not required.**

7. Ensure that the fuel system is free from leaks.

After the engine has stopped, you must wait for 10 minutes to allow the fuel pressure to be purged from the high-pressure fuel lines before any service or repair is performed on the engine fuel lines. The 10 minute wait will also allow static charge to dissipate from the low-pressure fuel system. If necessary, perform minor adjustments. Repair any leaks from the low-pressure fuel system and from the cooling, lubrication, or air systems. Replace any high-pressure fuel line that has leaked. Refer to Disassembly and Assembly Manual, "Fuel Injection Lines - Install".

If you inspect the engine in operation, always use the proper inspection procedure to avoid a fluid penetration hazard. Refer to Operation and Maintenance Manual, "General hazard Information".

If the engine will not start, refer to Troubleshooting, "Engine Cranks but will not Start".

Hand Priming (If Equipped)

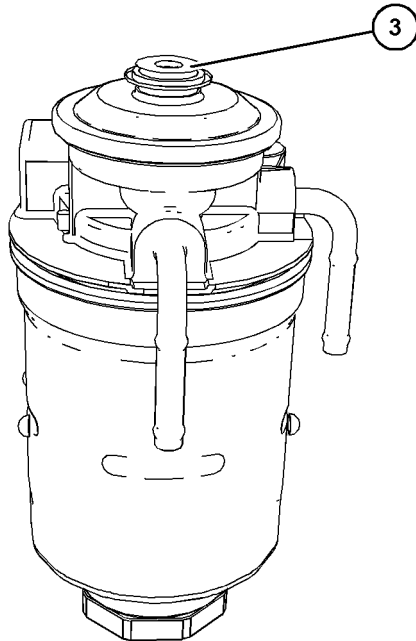

Illustration 89

g06583662

Operate the hand priming pump (3) to prime the low-pressure fuel lines.

i06299386

Fuel System Primary Filter (Water Separator) Element - Replace

SMCS Code: 1260-510-FQ; 1263-510-FQ

WARNING

Fuel leaked or spilled onto hot surfaces or electrical components can cause a fire. To help prevent possible injury, turn the start switch off when changing fuel filters or water separator elements. Clean up fuel spills immediately.

Note: Refer to Systems Operation, Testing, and Adjusting, “Cleanliness of Fuel System Components” for detailed information on the standards of cleanliness that must be observed during ALL work on the fuel system.

NOTICE

Ensure that the engine is stopped before any servicing or repair is performed.

Remove the Element

1. Turn the fuel supply valve (if equipped) to the OFF position before performing this maintenance.
2. Place a suitable container under the water separator in order to catch any fuel that might spill. Clean up any spilled fuel. Clean the outside body of the filter assembly.

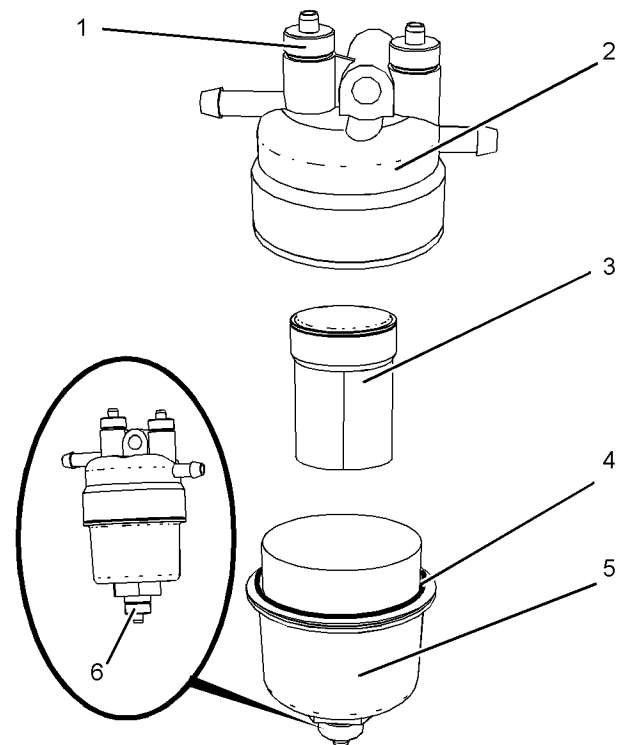

Illustration 90

g03891253

3. Open drain valve (6) and open vent screw (1) and drain the filter. Close drain screw and close vent screw. Use only hand pressure in order to tighten the drain screw and the vent screw.
4. Remove filter bowl (5) from filter (2) and remove filter element (3) from filter (2). Discard filter element (3).
5. Remove O ring seal (4) and discard O ring seal (4).
6. Ensure that all components are clean and dry.
7. Install new O ring seal (4) and install new filter element (3).

8. Install filter bowl (5) to filter (2) and tighten the filter bowl to a torque of 10 N·m (88 lb in).
9. If necessary, open the fuel supply valve. Remove the container and dispose of the fuel in a safe place.
10. The secondary filter element must be replaced at the same time as the primary filter element. Refer to the Operation and Maintenance Manual, "Fuel System Filter - Replace".

i07820738

Fuel System Primary Filter (Water Separator) Element - Replace

(Primary Fuel Filter With Water In Fuel (WIF) Sensor)

SMCS Code: 1260-510-FQ; 1263-510-FQ

WARNING

Fuel leaked or spilled onto hot surfaces or electrical components can cause a fire. To help prevent possible injury, turn the start switch off when changing fuel filters or water separator elements. Clean up fuel spills immediately.

Note: Refer to Systems Operation, Testing, and Adjusting, "Cleanliness of Fuel System Components" for detailed information on the standards of cleanliness that must be observed during ALL work on the fuel system.

NOTICE

Ensure that the engine is stopped before any servicing or repair is performed.

NOTICE

Care must be taken to ensure that fluids are contained during performance of inspection, maintenance, testing, adjusting, and repair of the product. Be prepared to collect the fluid with suitable containers before opening any compartment or disassembling any component containing fluids.

Dispose of all fluids according to local regulations and mandates.

Remove the Element

1. Turn the fuel supply valve (if equipped) to the OFF position before performing this maintenance.

2. Clean the outside body of the fuel filter assembly.
3. Place a suitable container under the water separator to catch any fuel that might spill. Clean up any spilled fuel.

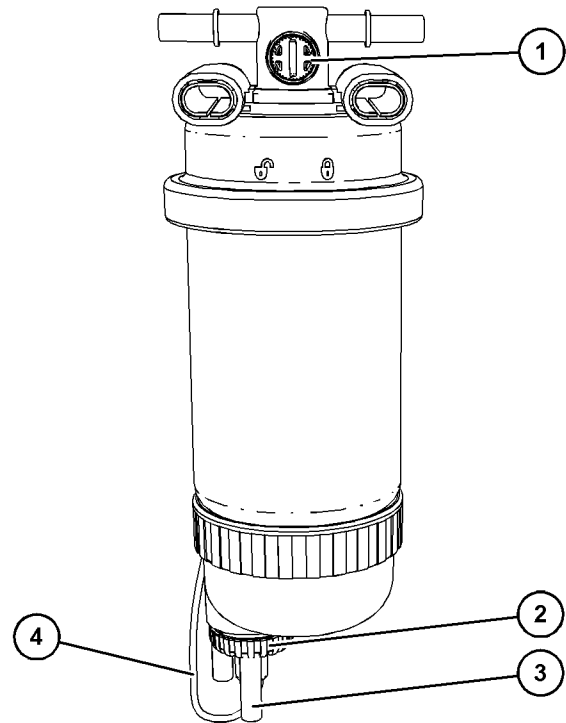

Illustration 91

g06446752

Typical example

4. Disconnect harness assembly (4) from the fuel filter assembly and position away from the fuel filter assembly to prevent the connection becoming wet during the filter change.
 5. Install a suitable tube onto drain valve outlet (3). Open drain valve (2) and capture all fluids in the suitable container.
 6. Loosen the vent screw (1).
 7. Allow the fuel to drain into the container. If the fuel will not drain, loosen the vent screw on the secondary fuel filter.
- Note:** In some applications, the vent screw on the secondary fuel filter will need to be open to drain the primary fuel filter.
8. Tighten the vent screw (1).
 9. If necessary, tighten the vent screw on the secondary fuel filter.
 10. Remove the tube from the drain valve outlet.

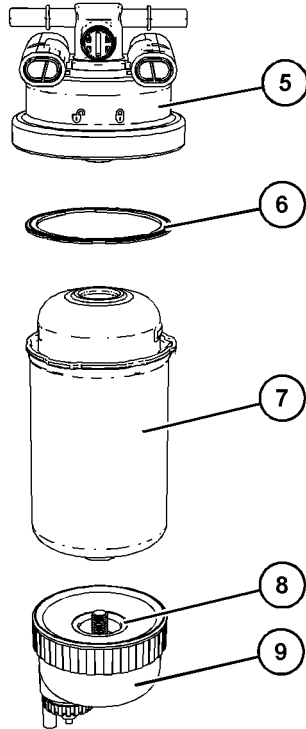

Illustration 92

g06446785

Typical example

11. Rotate filter bowl (9) counterclockwise and remove the filter bowl from the fuel filter assembly.
12. Rotate the filter element (7) counterclockwise and remove the filter element from fuel filter head (5).
13. Remove seal (6).
14. Remove O ring seal (8)

15. Clean filter bowl (9).

Install the New Filter Element

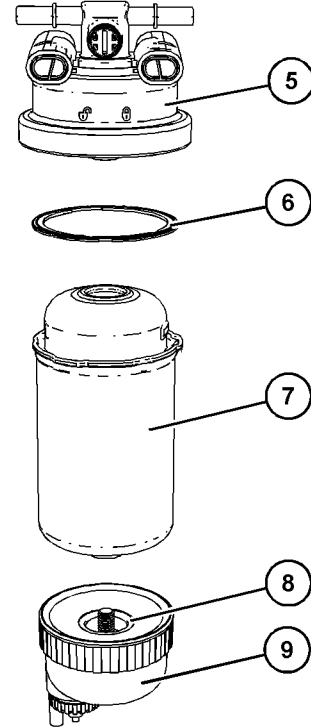

Illustration 93

g06446785

Typical example

1. Install new seal (6) to fuel filter (7).
2. Install fuel filter (7) to fuel filter head (5). Tighten the fuel filter securely by hand.
3. Install new O ring seal (8) to fuel filter bowl (9). Do NOT fill the bowl with fuel before the assembly is installed.
4. Install fuel filter bowl (9) to fuel filter (7). Tighten the fuel filter bowl securely by hand.

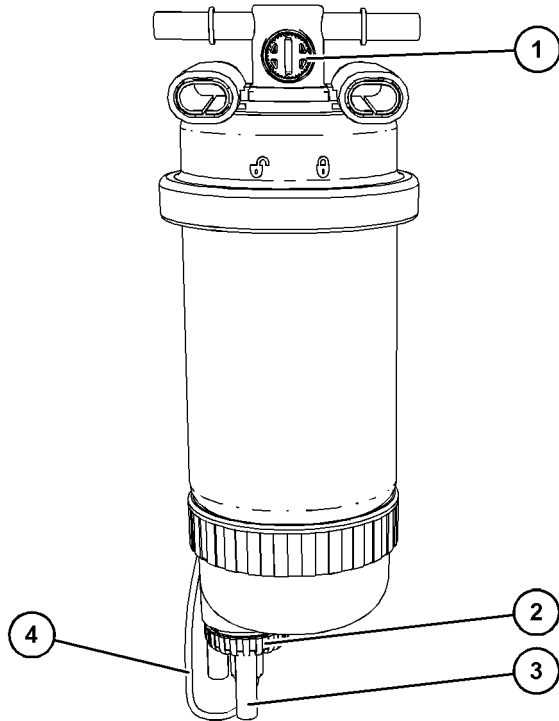

Illustration 94

g06446752

Typical example

5. Tighten drain valve (2) securely and ensure that drain valve outlet (3) is dry.
6. Remove the container and dispose of all fluids according to local regulations and mandates.
7. Connect harness assembly (4) to the fuel filter assembly.
8. The secondary fuel filter element must be replaced at the same time as the primary fuel filter element. Refer to this Operation and Maintenance Manual, "Fuel System Secondary Filter - Replace" for more information.

9. Turn the fuel supply valve (if equipped) to the ON position after performing this maintenance.

i07820721

Fuel System Primary Filter/ Water Separator - Drain (Primary Fuel Filter With Water In Fuel (WIF) Sensor)

SMCS Code: 1260-543; 1263-543

⚠ WARNING

Fuel leaked or spilled onto hot surfaces or electrical components can cause a fire. To help prevent possible injury, turn the start switch off when changing fuel filters or water separator elements. Clean up fuel spills immediately.

Note: Refer to Systems Operation, Testing, and Adjusting, "Cleanliness of Fuel System Components" for detailed information on the standards of cleanliness that must be observed during ALL work on the fuel system.

NOTICE

Ensure that the engine is stopped before any servicing or repair is performed.

NOTICE

The water separator is not a filter. The water separator separates water from the fuel. The engine should never be allowed to run with the water separator more than half full. Engine damage may result.

NOTICE

Care must be taken to ensure that fluids are contained during performance of inspection, maintenance, testing, adjusting, and repair of the product. Be prepared to collect the fluid with suitable containers before opening any compartment or disassembling any component containing fluids.

Dispose of all fluids according to local regulations and mandates.

i07905847

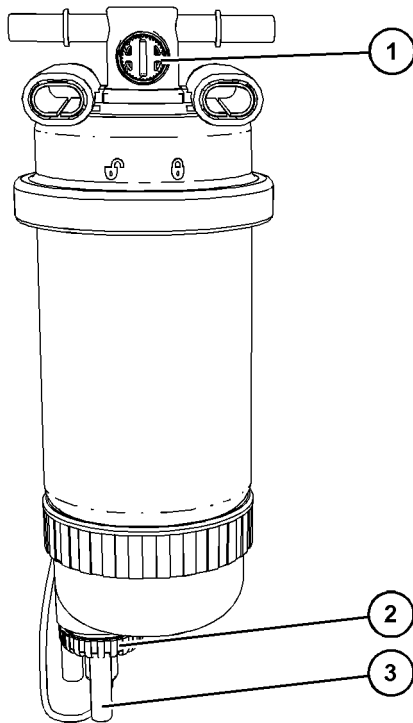

Illustration 95

g06446731

Primary fuel filter with Water In Fuel (WIF) sensor.

1. Attach a suitable length of hose to outlet (3) to capture the fluid that is being drained from the primary fuel filter assembly into a suitable container.
2. Open drain valve (2). Capture the draining fluid into the suitable container.
3. If necessary, open vent screw (1) to allow the fluid to be drained.
4. Close drain valve (2) hand tight.
5. If necessary, close vent screw (1) hand tight.
6. Dispose of the drained fluid correctly.

Also, drain water from the secondary fuel filter. Refer to this "Operation and Maintenance Manual" Fuel System Secondary Filter/Water Separator - Drain for more information.

NOTICE

The water separator is under suction during normal engine operation. Ensure that the drain valve and vent screw is tightened securely to help prevent air from entering the fuel system.

Fuel System Primary Filter/ Water Separator - Drain

SMCS Code: 1260-543; 1263-543

⚠ WARNING

Fuel leaked or spilled onto hot surfaces or electrical components can cause a fire. To help prevent possible injury, turn the start switch off when changing fuel filters or water separator elements. Clean up fuel spills immediately.

NOTICE

The water separator is not a filter. The water separator separates water from the fuel. The engine should never be allowed to run with the water separator more than half full. Engine damage may result.

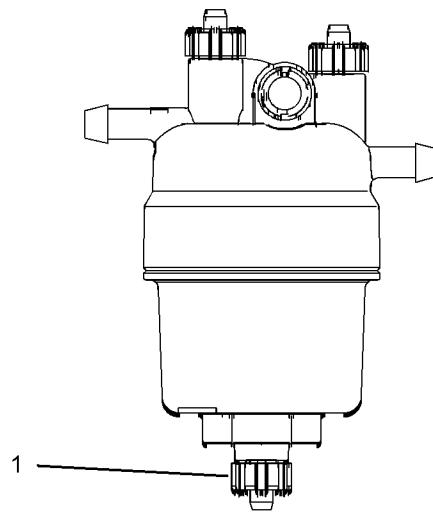

Illustration 96

g01316965

Typical example

1. Open drain (1). Catch the draining fluid in a suitable container. Dispose of the drained fluid correctly.
2. Close drain (1) use hand pressure only.

Also, drain water from the secondary fuel filter. Refer to the "Operation and Maintenance Manual" Fuel System Secondary Filter/Water Separator-Drain for more information.

NOTICE

The water separator is under suction during normal engine operation. Ensure that the drain valve is tightened securely to help prevent air from entering the fuel system.

i08106019

Fuel System Secondary Filter - Replace

SMCS Code: 1261-510-SE

WARNING

Fuel leaked or spilled onto hot surfaces or electrical components can cause a fire. To help prevent possible injury, turn the start switch off when changing fuel filters or water separator elements. Clean up fuel spills immediately.

NOTICE

Ensure that the engine is stopped before any servicing or repair is performed.

Refer to Systems Operation, Testing, and Adjusting, "Cleanliness of Fuel System Components" for detailed information on the standards of cleanliness that must be observed during ALL work on the fuel system.

Remove the Filter Element

1. Turn the fuel supply valve (if equipped) to the OFF position before performing this maintenance.
2. Place a suitable container under the fuel filter to catch any fuel that might spill. Clean up any spilled fuel. Clean the outside body of the filter assembly.

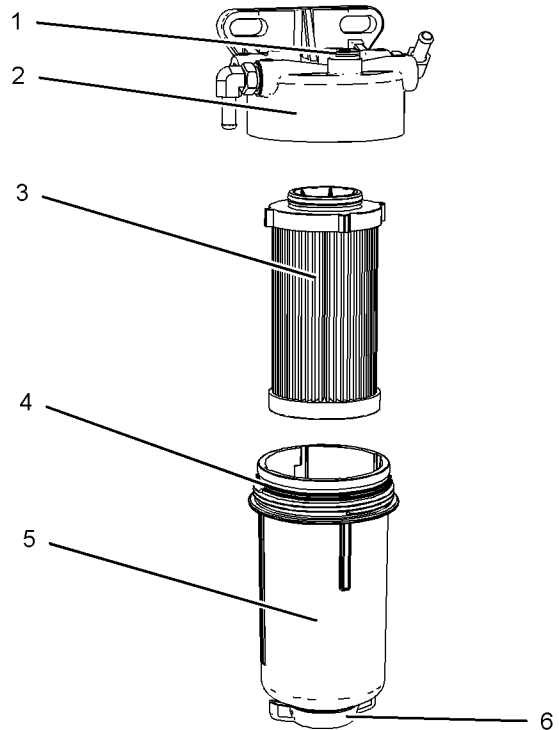

Illustration 97

g03891817

3. Open the drain valve (6) and if necessary, open vent screw (1). Allow the fuel to drain from the filter. Tighten vent screw (1) securely and close drain valve (6).
4. Use a suitable strap wrench remove the filter bowl (5) from filter base (2).
5. Remove the filter element (3) and discard the element. Remove the O ring seal (4) from filter bowl (5). Discard the old O ring seal.
6. Ensure the filter bowl (5) is clean and free from dirt.

Remove the Canister Fuel Filter

1. Turn the fuel supply valve (if equipped) to the OFF position before performing this maintenance.
2. Place a suitable container under the fuel filter to catch any fuel that might spill. Clean up any spilled fuel. Clean the outside body of the filter assembly.

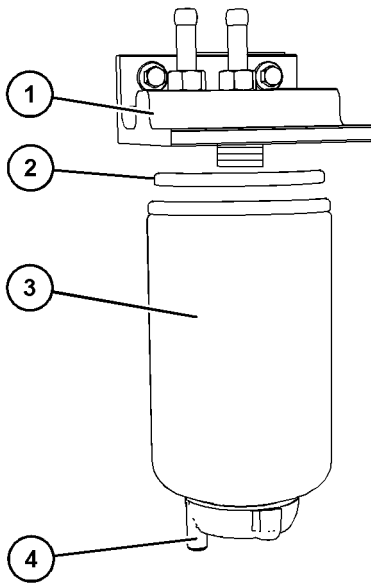

Illustration 98

g06545420

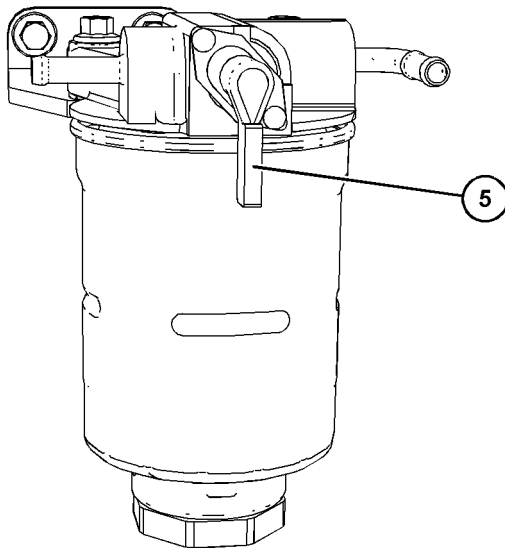

Illustration 99

g06545948

3. Turn the fuel filter head shut-off valve (5) (if equipped) to the OFF position.
4. Open the drain valve (4) and allow the fuel to drain from the fuel filter.
5. Use a suitable strap wrench to remove fuel filter (3) from fuel filter base (1).
6. Remove fuel filter (3) and discard the fuel filter. Ensure that O-ring seal (2) is removed from fuel filter base (1). Discard the O-ring seal.

Install the Filter Element

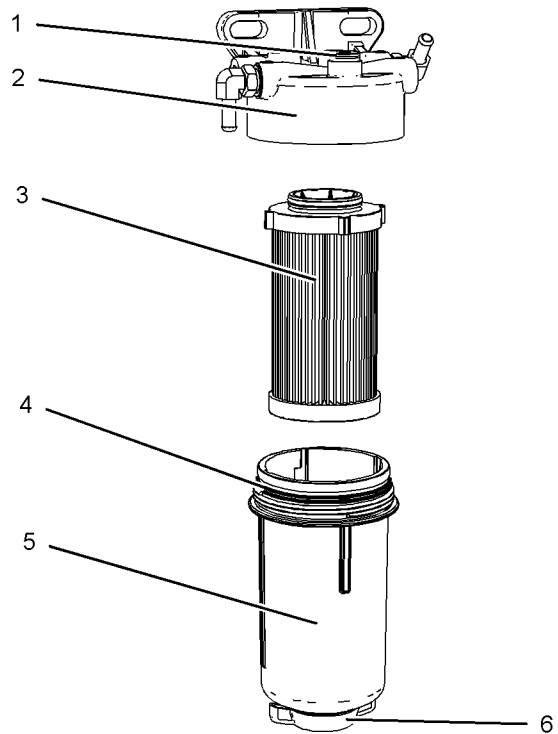

Illustration 100

g03891817

1. Install filter element (3) into filter base (2).
2. Install a new O ring seal (4) to filter bowl (5) and install filter bowl (5) to filter base (2). Do not use a tool to install the filter assembly. Use hand pressure only to tighten filter bowl.
3. Turn the fuel supply valve (if equipped) to the ON position
4. The primary fuel filter the secondary fuel filter must be replaced at the same time. Prime the fuel system, refer to this Operation and Maintenance Manual, "Fuel System - Prime".

Install the Canister Fuel Filter

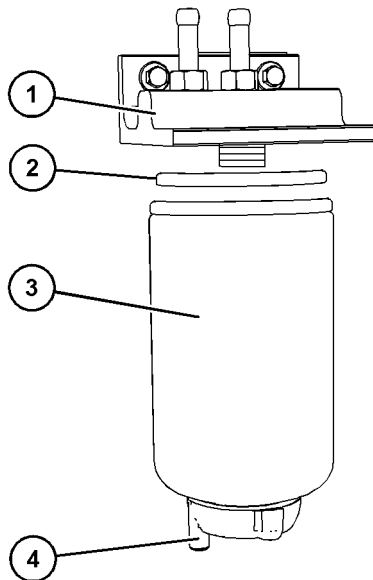

Illustration 101

g06545420

1. Ensure that O-ring seal (2) is in position on fuel filter (3). Lubricate the O-ring seal with clean diesel.
2. Install fuel filter (3) to fuel filter base (1) and tighten the fuel filter hand tight.

Note: Do not use a tool to tighten the fuel filter.

3. Close drain valve (4).
4. Turn the fuel supply valve (if equipped) to the ON position
5. The primary fuel filter the secondary fuel filter must be replaced at the same time. Prime the fuel system, refer to this Operation and Maintenance Manual, "Fuel System - Prime".

i06541262

Fuel System Secondary Filter/ Water Separator - Drain

SMCS Code: 1261-543; 1263-543

WARNING

Fuel leaked or spilled onto hot surfaces or electrical components can cause a fire. To help prevent possible injury, turn the start switch off when changing fuel filters or water separator elements. Clean up fuel spills immediately.

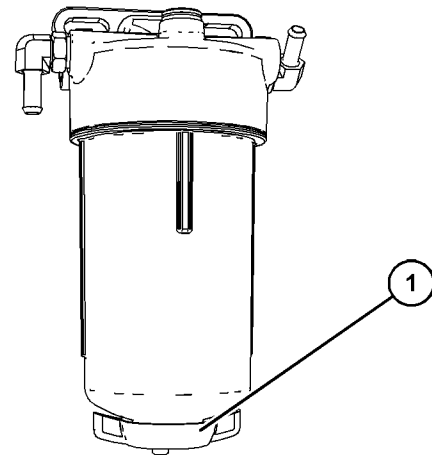

Illustration 102

g06014499

Typical example

1. Place a suitable container below filter. Open drain valve (1) and allow fluid to drain.
2. When necessary, close drain valve (1) with hand pressure only.

The procedure must be performed with primary fuel filter drain. Refer to this Operation and Maintenance Manual, Fuel System Primary Filter/Water Separator - Drain for more information.

i02348492

Fuel Tank Water and Sediment - Drain

SMCS Code: 1273-543-M&S

NOTICE

Care must be taken to ensure that fluids are contained during performance of inspection, maintenance, testing, adjusting and repair of the product. Be prepared to collect the fluid with suitable containers before opening any compartment or disassembling any component containing fluids.

Dispose of all fluids according to local regulations and mandates.

Fuel Tank

Fuel quality is critical to the performance and to the service life of the engine. Water in the fuel can cause excessive wear to the fuel system.

Water can be introduced into the fuel tank when the fuel tank is being filled.

Condensation occurs during the heating and cooling of fuel. The condensation occurs as the fuel passes through the fuel system and the fuel returns to the fuel tank. This causes water to accumulate in fuel tanks. Draining the fuel tank regularly and obtaining fuel from reliable sources can help to eliminate water in the fuel.

Drain the Water and the Sediment

Fuel tanks should contain some provision for draining water and draining sediment from the bottom of the fuel tanks.

Open the drain valve on the bottom of the fuel tank in order to drain the water and the sediment. Close the drain valve.

Check the fuel daily. Allow five minutes after the fuel tank has been filled before draining water and sediment from the fuel tank.

Fill the fuel tank after operating the engine in order to drive out moist air. This will help prevent condensation. Do not fill the tank to the top. The fuel expands as the fuel gets warm. The tank may overflow.

Some fuel tanks use supply pipes that allow water and sediment to settle below the end of the fuel supply pipe. Some fuel tanks use supply lines that take fuel directly from the bottom of the tank. If the engine is equipped with this system, regular maintenance of the fuel system filter is important.

Fuel Storage Tanks

Drain the water and the sediment from the fuel storage tank at the following intervals:

- Weekly
- Service intervals
- Refill of the tank

This will help prevent water or sediment from being pumped from the storage tank into the engine fuel tank.

If a bulk storage tank has been refilled or moved recently, allow adequate time for the sediment to settle before filling the engine fuel tank. Internal baffles in the bulk storage tank will also help trap sediment. Filtering fuel that is pumped from the storage tank helps to ensure the quality of the fuel. When possible, water separators should be used.

i07819616

Hoses and Clamps - Inspect/Replace

SMCS Code: 7554-510; 7554-040

WARNING

Contact with high pressure fuel may cause fluid penetration and burn hazards. High pressure fuel spray may cause a fire hazard. Failure to follow these inspection, maintenance and service instructions may cause personal injury or death.

If you inspect the engine in operation, always use the proper inspection procedure to avoid a fluid penetration hazard. Refer to Operation and Maintenance Manual, "General hazard Information" and Operation and Maintenance Manual, "High Pressure Fuel Lines" for the correct procedures.

Inspect all hoses for leaks that are caused by the following conditions:

- Cracking
- Softness
- Loose clamps

Replace hoses that are cracked or soft. Tighten any loose clamps.

Check for the following conditions:

- End fittings that are damaged or leaking
- Outer covering that is chafed or cut
- Exposed wire that is used for reinforcement
- Outer covering that is ballooning locally
- Flexible part of the hose that is kinked or crushed
- Armoring that is embedded in the outer covering

A constant torque hose clamp can be used in place of any standard hose clamp. Ensure that the constant torque hose clamp is the same size as the standard clamp.

Due to extreme temperature changes, the hose will harden. Hardening of the hoses will cause hose clamps to loosen. This can result in leaks. A constant torque hose clamp will help to prevent loose hose clamps.

Each installation application can be different. The differences depend on the following factors:

- Type of hose
- Type of fitting material
- Anticipated expansion and contraction of the hose
- Anticipated expansion and contraction of the fittings

Replace the Hoses and the Clamps

Refer to the OEM information for further information on removing and replacing fuel hoses (if equipped).

The following text describes a typical method of replacing coolant hoses. Refer to the OEM information for further information on the coolant system and the hoses for the coolant system.

WARNING

Pressurized System: Hot coolant can cause serious burns. To open the cooling system filler cap, stop the engine and wait until the cooling system components are cool. Loosen the cooling system pressure cap slowly in order to relieve the pressure.

1. Stop the engine. Allow the engine to cool.
2. Loosen the cooling system filler cap slowly to relieve any pressure. Remove the cooling system filler cap.

Note: Drain the coolant into a suitable, clean container. The coolant can be reused.

3. Drain the coolant from the cooling system to a level that is below the hose that is being replaced.
4. Remove the hose clamps.
5. Disconnect the old hose.
6. Replace the old hose with a new hose.
7. Install the hose clamps with a torque wrench.

Note: For the correct coolant, see this Operation and Maintenance Manual, "Fluid Recommendations".

8. Refill the cooling system. Refer to the OEM information for further information on refilling the cooling system.

9. Clean the cooling system filler cap. Inspect the cooling system filler cap's seals. Replace the cooling system filler cap if the seals are damaged. Install the cooling system filler cap.

10. Start the engine. Inspect the cooling system for leaks.

i02677504

Overhaul Considerations

SMCS Code: 7595-043

Reduced hours of operation at full load will result in a lower average power demand. A decreased average power demand should increase both the engine service life and the overhaul interval.

The need for an overhaul is generally indicated by increased fuel consumption and by reduced power.

The following factors are important when a decision is being made on the proper time for an engine overhaul:

- The need for preventive maintenance
- The quality of the fuel that is being used
- The operating conditions
- The results of the S·O·S analysis

Oil Consumption as an Overhaul Indicator

Oil consumption, fuel consumption, and maintenance information can be used to estimate the total operating cost for your Caterpillar engine. Oil consumption can also be used to estimate the required capacity of a makeup oil tank that is suitable for the maintenance intervals.

Oil consumption is in proportion to the percentage of the rated engine load. As the percentage of the engine load is increased, the amount of oil that is consumed per hour also increases.

The oil consumption rate (brake specific oil consumption) is measured in grams per kW/h (lb per bhp). The brake specific oil consumption (BSOC) depends on the engine load. Consult your Caterpillar dealer for assistance in determining the typical oil consumption rate for your engine.

When an engine's oil consumption has risen to three times the original oil consumption rate due to normal wear, an engine overhaul should be scheduled. There may be a corresponding increase in blowby and a slight increase in fuel consumption.

Overhaul Recommendation

Caterpillar recommends replacement of the engine. For more information about replacement of the engine, see your Caterpillar dealer. Engine components are available in a standard size only.

Cleaning

Caterpillar recommends the use of Hydrosolv Liquid Cleaners. Table 17 lists the Hydrosolv Liquid Cleaners that are available from your Caterpillar dealer.

Table 17

HydrosolvLiquid Cleaners		
Part Number	Description	Size
1U-8812	Hydrosolv4165	4 L (1 US gallon)
1U-5490		19 L (5 US gallon)
8T-7570		208 L (55 US gallon)
1U-8804	Hydrosolv100	4 L (1 US gallon)
1U-5492		19 L (5 US gallon)
8T-5571		208 L (55 US gallon)

Obtain Coolant Analysis

The concentration of supplemental coolant additive (SCA) should be checked regularly with test kits or with S·O·S Coolant Analysis (Level I).

A coolant analysis can be conducted in order to verify the condition of the water that is being used in the cooling system. A full water analysis can be obtained by consulting your local water utility company or an agricultural agent. Private laboratories are also available for water analysis.

Caterpillar Inc. recommends an S·O·S Coolant Analysis (Level II).

S·O·S Coolant Analysis (Level II)

An S·O·S Coolant Analysis (Level II) is a comprehensive coolant analysis which completely analyzes the coolant and the effects on the cooling system. An S·O·S Coolant Analysis (Level II) provides the following information:

- Complete S·O·S Coolant Analysis (Level I)
- Visual inspection of properties
- Identification of metal corrosion
- Identification of contaminants
- Identification of built up impurities (corrosion and scale)

S·O·S Coolant Analysis (Level II) provides a report of the results of both the analysis and the maintenance recommendations.

For more information about coolant analysis, see your Caterpillar dealer.

i09670468

Radiator - Clean

SMCS Code: 1353-070

Note: Adjust the frequency of cleaning according to the effects of the operating environment.

Inspect the radiator for these items: damaged fins, corrosion, dirt, grease, insects, leaves, oil, and other debris. Clean the radiator, if necessary.

WARNING

Personal injury can result from air pressure.

Personal injury can result without following proper procedure. When using pressure air, wear a protective face shield and protective clothing.

The maximum air pressure for cleaning purposes must be reduced to 205 kPa (30 psi) when the air nozzle is deadheaded.

Pressurized air is the preferred method for removing loose debris. Direct the air in the opposite direction of the air flow. Hold the nozzle approximately 6 mm (0.25 inch) away from the fins. Slowly move the air nozzle in a direction that is parallel with the tubes. This movement will remove debris that is between the tubes.

Pressurized water may also be used for cleaning. The maximum water pressure for cleaning purposes must be less than 275 kPa (40 psi). Use pressurized water to soften mud. Clean the core from the front and the rear.

Use a degreaser and steam for removal of oil and grease. Clean the front and the rear of the core. Wash the core with detergent and hot water. Thoroughly rinse the core with clean water.

Maintenance Section
Radiator Mounts - Inspect

After cleaning, start the engine and bring the engine to high idle. This procedure will help in the removal of debris and drying of the core. Stop the engine. Use a light bulb behind the core to inspect the core for cleanliness. Repeat the cleaning, if necessary.

Inspect the fins for damage. Bent fins may be opened with a "comb". Inspect these items for good condition: welds, mounting brackets, air lines, connections, clamps, and seals. Make repairs, if necessary.

i09672754

Radiator Mounts - Inspect

SMCS Code: 1353-040-MT

There are 2 anti vibration mounts (AVM) (2) on the radiator support bracket (1). The anti vibration mounts require inspection at specific maintenance intervals.

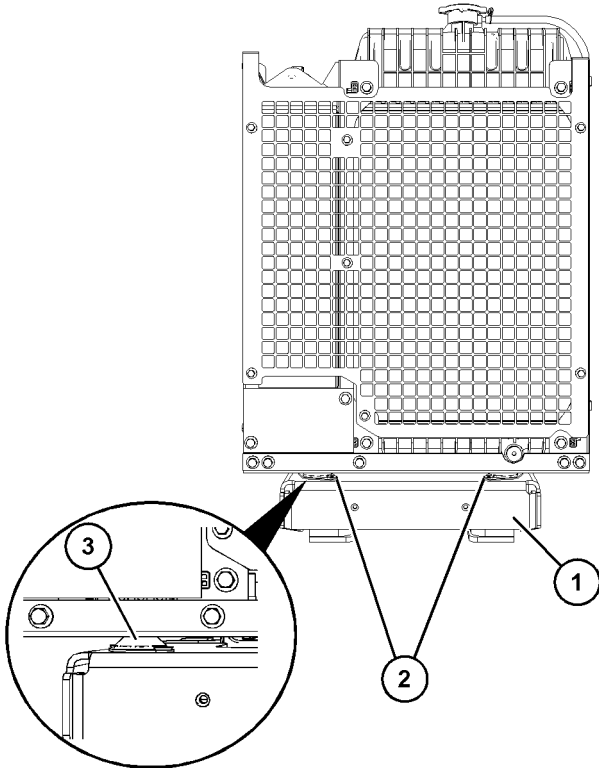

Illustration 103

g07520988

Typical example of a 4 cylinder OPU

- (1) Radiator support bracket
- (2) Radiator anti vibration mounts
- (3) Radiator anti vibration mounts rubber compound

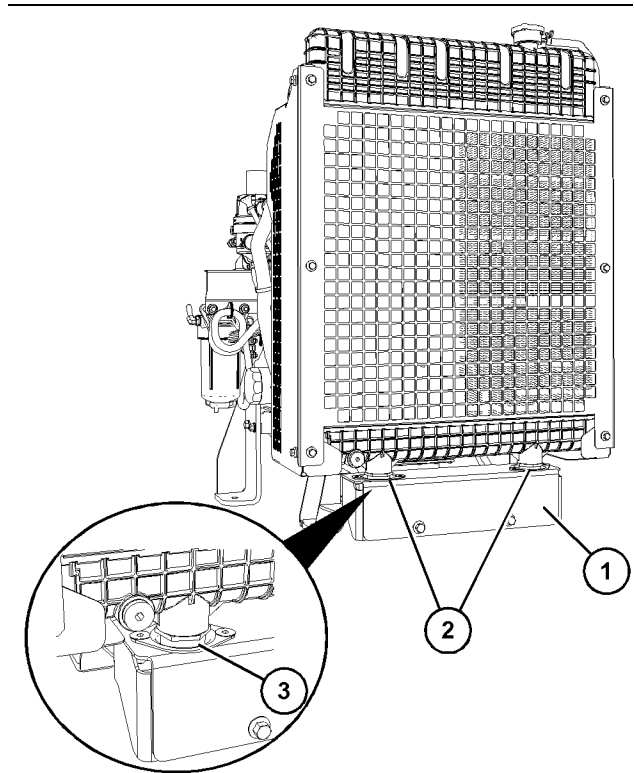

Illustration 104

g07520992

Typical example of a 3 cylinder OPU

- (1) Radiator support bracket
- (2) Radiator anti vibration mounts
- (3) Radiator anti vibration mounts rubber compound

The radiator may need to be lifted to inspect the 2 anti vibration mounts (AVM). Refer to Disassembly and Assembly, Radiator - Remove and Install.

Inspect the anti vibration mounts for wear, cracking, and damage. If the anti vibration mounts appear to be worn, cracked, or damaged replace the anti vibration mount. Refer to Disassembly and Assembly, Radiator Anti Vibration Mounts - Remove and Install.

i00651416

Starting Motor - Inspect

SMCS Code: 1451-040; 1453-040

Caterpillar Inc. recommends a scheduled inspection of the starting motor. If the starting motor fails, the engine may not start in an emergency situation.

Check the starting motor for proper operation. Check the electrical connections and clean the electrical connections. Refer to the Service Manual for more information on the checking procedure and for specifications or consult your Caterpillar dealer for assistance.

i07824273

Turbocharger - Inspect

SMCS Code: 1052; 1052-040

A regular visual inspection of the turbocharger is recommended. Any fumes from the crankcase are filtered through the air inlet system. Therefore, by-products from oil and from combustion can collect in the turbocharger compressor housing. Over time, this buildup can contribute to loss of engine power, increased black smoke and overall loss of engine efficiency.

If the turbocharger fails during engine operation, damage to the turbocharger compressor wheel and/or to the engine may occur. Damage to the turbocharger compressor wheel can cause damage to the pistons, the valves, and the cylinder head.

Refer to Systems Operation Testing and Adjusting, Air Inlet and Exhaust System - Inspect and Wastegate - Test for more information.

i07824276

Walk-Around Inspection

SMCS Code: 1000-040

Inspect the Engine for Leaks and for Loose Connections

A walk-around inspection should only take a few minutes. When the time is taken to perform these checks, costly repairs and accidents can be avoided.

For maximum engine service life, make a thorough inspection of the engine compartment before starting the engine. Look for items such as fuel leaks, oil leaks, coolant leaks, loose bolts, worn belts, loose connections, and debris build-up. Make repairs, as needed:

- The guards must be in the correct place. Repair damaged guards or replace missing guards and fixings.
- Wipe all caps and plugs before the engine is serviced to reduce the chance of system contamination.

NOTICE

For any type of leak (coolant, lube, or fuel) clean up the fluid. If leaking is observed, find the source and correct the leak. If leaking is suspected, check the fluid levels more often than recommended until the leak is found or fixed, or until the suspicion of a leak is proved to be unwarranted.

NOTICE

Accumulated grease and/or oil on an engine is a fire hazard. Remove the accumulated grease and oil. Refer to this Operation and Maintenance Manual, "Engine - Clean" for more information.

- Ensure that the cooling system hoses are correctly clamped and that the cooling system hoses are tight. Check for leaks. Check the condition of all pipes.
- Inspect the water pump for coolant leaks.

Excessive coolant leakage may indicate the need to replace the water pump. Remove the water pump. Refer to Disassembly and Assembly, "Water Pump - Remove and Install" for the correct procedure.

- Inspect the lubrication system for leaks at the front crankshaft seal, the rear crankshaft seal, the oil pan, the oil filters, and the rocker cover.
- Inspect the piping for the air intake system and the elbows for cracks and for loose clamps. Ensure that hoses and tubes are not contacting other hoses, tubes, or the wiring harnesses.
- Ensure that the areas around the rotating parts are clear.
- Inspect the alternator belts and any accessory drive belts for cracks, breaks, or other damage.

Note: Belts for multiple groove pulleys must be replaced as matched sets. If only one belt is replaced, the belt will carry more load than the belts that are not replaced. The older belts are stretched. The additional load on the new belt could cause the belt to break.

- Inspect the wiring harness for damage.

High-Pressure Fuel Lines

WARNING

Contact with high pressure fuel may cause fluid penetration and burn hazards. High pressure fuel spray may cause a fire hazard. Failure to follow these inspection, maintenance and service instructions may cause personal injury or death.

NOTICE

Ensure that all adjustments and repairs that are carried out to the fuel system are performed by authorized personnel that have the correct training.

Before beginning ANY work on the fuel system, refer to this Operation and Maintenance Manual, "General Hazard Information and High-Pressure Fuel Lines" for safety information.

Refer to System Operation, Testing and Adjusting, "Cleanliness of Fuel System Components" for detailed information on the standards of cleanliness that must be observed during ALL work on the fuel system.

NOTICE

Care must be taken to ensure that fluids are contained during performance of inspection, maintenance, testing, adjusting and repair of the product. Be prepared to collect the fluid with suitable containers before opening any compartment or disassembling any component containing fluids.

Dispose of all fluids according to local regulations and mandates.

After the engine has stopped, wait 10 minutes to allow the fuel pressure to be purged from the high-pressure fuel lines before any service or repair is performed. The 10 minute wait will also allow static charge to dissipate from the low-pressure fuel system. If necessary, perform minor adjustments. Repair any leaks from the low-pressure fuel system and from the cooling, lubrication, or air systems. Replace any high-pressure fuel line that has leaked. Refer to Disassembly and Assembly Manual, "Fuel Injection Lines - remove" and Disassembly and Assembly Manual, "Fuel Injection Lines - Install" for the correct procedures.

If you inspect the engine in operation, always use the proper inspection procedure to avoid a fluid penetration hazard. Refer to Operation and Maintenance Manual, "General hazard Information".

Visually inspect the high-pressure fuel lines for damage or signs of fuel leakage. Replace any damaged high-pressure fuel lines or high-pressure fuel lines that have leaked.

Ensure that all clips on the high-pressure fuel lines are in place and that the clips are not loose.

- Inspect the rest of the fuel system for leaks. Look for loose fuel line clamps.
- Drain the water and the sediment from the fuel tank daily.

- Inspect the wiring and the wiring harnesses for loose connections and for worn wires or frayed wires. Check for any loose cable straps or missing cable straps.
- Inspect the ground strap for a good connection and for good condition.
- Disconnect any battery chargers that are not protected against the current drain of the starting motor. Check the condition and the electrolyte level of the batteries, unless the engine is equipped with a maintenance free battery.
- Check the condition of the gauges. Replace any gauges that are cracked. Replace any gauge that cannot be calibrated.

Engine Aftertreatment

Check that all clamps, clips, and cable straps are secure and in good condition.

i10061507

Water Pump - Inspect

SMCS Code: 1361; 1361-040

A failed water pump may cause severe engine overheating problems that could result in the following conditions:

- Cracks in the cylinder head
 - A piston seizure
 - Other potential damage to the engine
1. Inspect the exterior components of the cooling system for coolant leakage. Refer to Systems Operation Testing and Adjusting, Cooling System - Check and Systems Operation Testing and Adjusting, Cooling System - Inspect for more information.

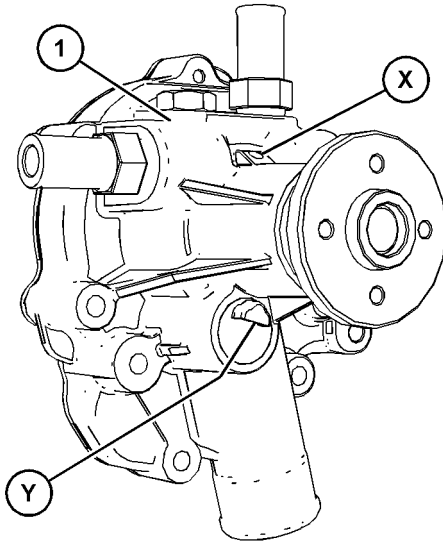

Illustration 105

g07525306

Typical example

2. If water pump (1) is leaking coolant and grease from the vent hole in Position (X), Caterpillar recommends that the water pump is replaced. Refer to Disassembly and Assembly for the correct procedure.

Note: A coolant leak from the vent hole in Position (X) means that the weep chamber is full, the weep hole in Position (Y) is blocked. Coolant may have entered the water pump bearing. The water pump bearing may eventually fail due to insufficient lubrication.

3. If the water pump is leaking coolant from vent hole in Position (Y), the coolant leak needs to be investigated.

Note: A small amount of coolant leakage across the surface of the seal for the jacket water pump is normal. This leakage is required to provide lubrication for this type of seal. A hole is provided in the water pump housing to allow this coolant/seal lubricant to drain from the water pump housing. Intermittent leakage of small amounts of coolant from this hole is not an indication of water pump seal failure.

Warranty Section

Warranty Information

i08769122

Emissions Warranty Information

SMCS Code: 1000

The certifying engine manufacturer warrants to the ultimate purchaser and each subsequent purchaser that:

1. New non-road diesel engines and stationary diesel engines less than 10 L per cylinder (including Tier 1 and Tier 2 marine engines < 37 kW, but excluding locomotive and other marine engines) operated and serviced in the United States and Canada, including all parts of their emission control systems (“emission related components”), are:
 - a. Designed, built, and equipped so as to conform, at the time of sale, with applicable emission standards prescribed by the United States Environmental Protection Agency (EPA) by way of regulation.
 - b. Free from defects in materials and workmanship in emission-related components that can cause the engine to fail to conform to applicable emission standards for the warranty period.
2. New non-road diesel engines (including Tier 1 and Tier 2 marine propulsion engines < 37 kW and Tier 1 through Tier 4 marine auxiliary engines < 37 kW, but excluding locomotive and other marine engines) operated and serviced in the state of California, including all parts of their emission control systems (“emission related components”), are:
 - a. Designed, built, and equipped so as to conform, at the time of sale, to all applicable regulations adopted by the California Air Resources Board (ARB).
 - b. Free from defects in materials and workmanship which cause the failure of an emission-related component to be identical in all material respects to the component as described in the engine manufacturer's application for certification for the warranty period.
3. New non-road diesel engines installed in construction machines conforming to the South Korean regulations for construction machines manufactured after January 1, 2015, and operated and serviced in South Korea, including all parts of their emission control systems (“emission related components”), are:
 - a. Designed, built, and equipped so as to conform, at the time of sale, with applicable emission standards prescribed in the Enforcement Rule of the Clean Air Conservation Act promulgated by South Korea MOE.
 - b. Free from defects in materials and workmanship in emission-related components that can cause the engine to fail to conform to applicable emission standards for the warranty period.
4. New China non-road 4 mobile diesel engines operated and serviced in China, including all parts of their emission control systems (“emission related components”), are:
 - a. Designed, built, and equipped so as to conform, at the time of manufacture, sale, and import with applicable emission standards in the promulgated by Enforcement Rule of the Clean Air Conservation Act Ministry of Ecology and Environment (MEE).
 - b. Free from defects in materials and workmanship in emission-related components that can cause the engine to fail to conform to applicable emission standards for the warranty period.

A detailed explanation of the Emission Control Warranty that is applicable to new non-road and stationary diesel engines, including the components covered and the warranty period, is found in the Emission Control Warranty statement available at the Cat Warranty website. Consult your authorized Cat dealer to determine if your engine is subject to an Emission Control Warranty, and to obtain a copy of the applicable warranty publication.

Reference Information Section

i00819749

Engine Ratings

i08274659

Engine Rating Conditions

SMCS Code: 1000

All engine ratings are in compliance with the following standard ambient air conditions of "SAE J1349":

- 99 kPa (29.3 inches of Hg)
- 30 percent relative humidity
- A temperature of 25 °C (77 °F)

Ratings relate to the standard conditions of "ISO8665", of "ISO3046/1", of "DIN6271", and of "BS5514".

The engine ratings are based on the following fuel specifications:

- Low heat value (LHV) of the fuel of 42 780 kJ/kg (18,390 Btu/lb) at 29 °C (84 °F)
- Gravity (API) of 35 degrees at 15 °C (60 °F)
- Specific gravity of .849 at 15 °C (60 °F)
- Density of 850 kg/m³ (7.085 lb/US gal)

The engine ratings are gross output ratings.

Gross Output Ratings – The total output capability of the engine that is equipped with standard accessories.

Standard accessories include the following components:

- Oil pumps
- Fuel pumps
- Water pumps

Subtract the power that is required to drive auxiliary components from the gross output. This action will produce the net power that is available for the external load (flywheel).

Engine Rating Definitions

SMCS Code: 1000

It is important to know the use of the engine so that the rating will match the operating profile. The proper rating selection is also important so that the customer's perception of price and value is realized.

In selecting a rating for a specific application, the most important consideration is the time that is spent at full throttle. These rating definitions identify the percent of time at full throttle. The definitions also identify the corresponding times below rated rpm.

Note: The examples of the applications are only for reference. For an exact determination of the appropriate rating, follow the OEM specifications or consult your Caterpillar dealer.

A Rating – This rating is used for heavy-duty applications that are operated at rated load and at rated rpm up to 100 percent. This rating is used for engines that operate without interruption of load cycling. Typical applications include the following examples: pipeline pumping and ventilation.

B Rating – This rating is used when power and/or rpm are cyclic. The engine should be run at full load. The engine should not exceed 80 percent of the duty cycle. Typical applications include the following examples: irrigation, operation where normal pump demand is 85 percent of the engine rating, oil pumping/drilling, field mechanical pumping/drilling and stationary/plant air compressors.

C Rating – This rating is used when power and/or rpm are cyclic. The horsepower and the rpm of the engine can be utilized continuously for one hour. This is followed by one hour of operation at the A rating or below the A rating. The engine should be run at full load. The engine should not exceed 50 percent of the duty cycle. Typical applications include the following examples: agricultural tractors, harvesters and combines, off-highway trucks, fire pumps, blast hole drills, rock crushers, wood chippers with high torque rise and oil field hoisting.

D Rating – This rating is used when rated power is required for periodic overloads. The maximum horsepower and the rpm of the engine can be utilized continuously for a maximum of 30 minutes. This is followed by one hour of operation at the C rating. The engine should be run at full load. The engine should not exceed 10 percent of the duty cycle. Typical applications include the following examples: offshore cranes, runway snow blowers, water well drills, portable air compressors and fire pump certification power.

E Rating – This rating is used when rated power is required for a short time for initial starting or for sudden overload. The rating is also used for emergency service when standard power is not

Reference Information Section
Engine Rating Definitions

available. The horsepower and the rpm of the engine can be utilized continuously for a maximum of 15 minutes. This is followed by one hour of operation at the C rating or by the duration of the emergency. The engine should be run at full load. The engine should not exceed 5 percent of the duty cycle. Typical applications include the following examples: standby centrifugal water pumps, oil field well servicing, crash trucks, portable air compressors and gas turbine starting motors.

NOTICE

Operating engines above the rating definitions can result in shorter service life before overhaul.

Customer Service

i07191578

Customer Assistance

SMCS Code: 1000

USA and Canada

When a problem arises concerning the operation or the service of an engine, the problem will normally be managed by the dealer in your area.

Outside of the USA and of Canada

If a problem arises outside the USA and outside Canada, and if the problem cannot be resolved at the dealer level, consult the appropriate Caterpillar office.

Latin America, Mexico, Carribean
Caterpillar Americas Co.
701 Waterford Way, Suite 200
Miami, FL 33126-4670
USA
Phone: 305-476-6800
Fax: 305-476-6801

Europe, Africa, and Middle East
Caterpillar Overseas S.A.
76 Route de Frontenex
P.O. Box 6000
CH-1211 Geneva 6
Switzerland
Phone: 22-849-4444
Fax: 22-849-4544

Far East
Caterpillar Asia Pte. Ltd.
7 Tractor Road
Jurong, Singapore 627968
Republic of Singapore
Phone: 65-662-8333
Fax: 65-662-8302

China
Caterpillar China Ltd.
37/F., The Lee Gardens
33 Hysan Avenue
Causeway Bay
G.P.O. Box 3069
Hong Kong
Phone: 852-2848-0333
Fax: 852-2848-0440

Australia and New Zealand
Caterpillar of Australia Ltd.
1 Caterpillar Drive
Private Mail Bag 4
Tullamarine, Victoria 3043
Australia
Phone: 03-9953-9333
Fax: 03-9335-3366

i03655027

Ordering Replacement Parts

SMCS Code: 7567

WARNING

When replacement parts are required for this product Caterpillar recommends using Caterpillar replacement parts or parts with equivalent specifications including, but not limited to, physical dimensions, type, strength and material.

Failure to heed this warning can lead to premature failures, product damage, personal injury or death.

Quality Caterpillar replacement parts are available from Caterpillar dealers throughout the world. Caterpillar dealers' parts inventories are up-to-date. The parts stocks include all of the parts that are normally needed to protect your Caterpillar engine investment.

When you order parts, please specify the following information:

- When a Caterpillar engine requires maintenance and/or repair, provide the dealer with all the information that is stamped on the Information Plate. Refer to this Operation and Maintenance Manual, "Plate Locations and Film Locations".
- Part number
- Part name
- Quantity

If there is a question concerning the part number, please provide your dealer with a complete description of the needed item.

Discuss the problem with the dealer. Inform the dealer about the conditions of the problem and the nature of the problem. Inform the dealer about when the problem occurs. This will help the dealer in troubleshooting the problem and solving the problem faster.

Reference Materials

i08530562

Maintenance Records

SMCS Code: 1000

Caterpillar recommends the retention of accurate maintenance records. Accurate maintenance records can be used for the following purposes:

- Determine operating costs.
- Establish maintenance schedules for other engines that are operated in the same environment.
- Show compliance with the required maintenance practices and maintenance intervals.

Maintenance records can be used for various other business decisions that are related to engine maintenance.

Maintenance records are a key element of a maintenance program that is managed. Accurate maintenance records can help your Cat dealer to fine-tune the recommended maintenance intervals to meet the specific operating situation. These recommendations should result in a lower engine operating cost.

Records should be kept for the following items:

Fuel Consumption – A record of fuel consumption is essential to determine when the load sensitive components should be inspected or repaired. Fuel consumption assists in determining overhaul intervals.

Service Hours – A record of service hours is essential to determine when the speed sensitive components should be inspected or repaired.

Documents – These items should be easy to obtain, and these items should be kept in the engine history file. All documents should show this information: date, service hours, fuel consumption, unit number, and engine serial number. The following types of documents should be kept as proof of maintenance or repair for warranty:

Keep the following types of documents as proof of maintenance for warranty. Also, keep these types of documents as proof of repair for warranty:

- Dealer work orders and itemized bills
- Owner repair costs
- Owner receipts
- Maintenance log

Index

A

After Starting Engine	55
After Stopping Engine	60
Aftercooler Core - Inspect	77
Alarms and Shutoffs	49
Alarms	50
Shutoffs	49
Alternator - Inspect	77
Alternator and Fan Belts - Replace (Multi-V Stretch Belt)	77
Installation Procedure	79
Removal Procedure	77
Alternator and Fan Belts - Replace (Single- V Belt)	80
Installation Procedure	81
Removal Procedure	80

B

Battery - Replace	81
Battery Electrolyte Level - Check	82
Battery or Battery Cable - Disconnect	82
Before Starting Engine	23, 53
Belts - Inspect/Adjust	83
Adjust	84
Inspection	83
Belts - Inspect/Adjust (Multi-V Stretch Belt)	83
Inspection	83
Burn Prevention	17
Batteries	18
Coolant	17
Diesel Fuel	18
Engine and Aftertreatment System	18
Induction System	17
Oils	18

C

Cold Weather Operation	62
Hints for Cold-Weather Operation	62
Idling the Engine	63
Recommendations for Coolant Warm Up	63
Recommendations for the Coolant	63
Viscosity of the Engine Lubrication Oil	62
Cold Weather Starting	54
Configuration Parameters	52
Cooling System Coolant (DEAC) - Change	84
Cooling Systems with Heavy Deposits or Plugging	88

Drain	85
Drain Plugs for Factory Installed Radiators	87
Drain Plugs for OPU Radiators	86
Fill	88
Flush	87
Cooling System Coolant (ELC) - Change	89
Drain	89
Drain Plugs for Factory Installed Radiators	91
Drain Plugs for OPU Radiators	90
Fill	92
Flush	91
Cooling System Coolant Extender (ELC) - Add	93
Cooling System Coolant Level - Check	93
Factory Installed Radiators	95
Open Power Unit (OPU) Radiators	94
Radiator Cap	96
Cooling System Coolant Sample (Level 1) - Obtain	96
Cooling System Coolant Sample (Level 2) - Obtain	97
Cooling System Water Temperature Regulator - Replace	97
Crankcase Breather (Canister) - Replace	98
Crankcase Breather (Canister) - Replace (Open Crankcase Breather)	99
Crushing Prevention and Cutting Prevention ..	20
Customer Assistance	129
Outside of the USA and of Canada	129
USA and Canada	129
Customer Service	129

D

Diagnostic Lamp	51
-----------------------	----

E

Electrical System	24
Grounding Practices	25
Emergency Stopping	60
Emergency Stop Button	60
Emissions Warranty Information	126
Engaging the Driven Equipment	58
Engine - Clean	101
Aftertreatment	102
Engine Air Cleaner Element - Replace	102

Servicing the Air Cleaner Elements.....	102	Maintenance	4
Engine Air Cleaner Service Indicator -		Maintenance Intervals	5
Inspect	103	Operation	4
Test the Service Indicator	104	Overhaul	5
Type 1 Service Indicator	103	Safety	4
Type 2 Service Indicator	103	Fuel and the Effect from Cold Weather	64
Engine Air Precleaner - Check/Clean	104	Fuel Conservation Practices	59
Engine Diagnostics	51	Fuel Related Components in Cold Weather ...	64
Engine Electronics.....	25	Fuel Filters	65
Engine Mounts - Inspect.....	104	Fuel Heaters	65
Engine Oil and Filter - Change	106	Fuel Tanks	64
Drain the Engine Oil.....	106	Fuel System - Prime	109
Fill the Engine Crankcase.....	107	Hand Priming (If Equipped)	111
Oil and Filter Change Intervals	106	Fuel System Primary Filter (Water	
Replace the Oil Filter	106	Separator) Element - Replace.....	111
Engine Oil Level - Check.....	105	Remove the Element	111
Engine Oil Sample - Obtain.....	105	Fuel System Primary Filter (Water	
Obtain the Sample and the Analysis	105	Separator) Element - Replace (Primary	
Engine Operation	57	Fuel Filter With Water In Fuel (WIF)	
Carbon Dioxide (CO ₂) Emissions		Sensor)	112
Statement.....	58	Install the New Filter Element.....	113
Engine Operation and the Aftertreatment		Remove the Element	112
System	58	Fuel System Primary Filter/Water	
Reduction of Particulate Emissions.....	57	Separator - Drain	115
Variable Speed Engine	57	Fuel System Primary Filter/Water	
Engine Operation with Active Diagnostic		Separator - Drain (Primary Fuel Filter With	
Codes	51	Water In Fuel (WIF) Sensor)	114
Engine Operation with Intermittent		Fuel System Secondary Filter - Replace	116
Diagnostic Codes	51	Remove the Filter Element	116
Engine Rating Conditions.....	127	Fuel System Secondary Filter/Water	
Engine Rating Definitions.....	127	Separator - Drain	118
Engine Ratings	127	Fuel Tank Water and Sediment - Drain	118
Engine Starting.....	24, 53	Drain the Water and the Sediment	119
Engine Stopping	24, 60	Fuel Storage Tanks.....	119
Engine Valve Lash - Check	108	Fuel Tank	118
F		G	
Fan Clearance - Check	108	Gauges and Indicators	45
Factory Installed Radiators.....	109	Indicators and Lamps	45
Open Power Unit (OPU) Radiators	108	General Hazard Information.....	13
Fault Logging.....	51	Containing Fluid Spillage.....	15
Features and Controls.....	46	Dispose of Waste Properly	17
Fire Prevention and Explosion Prevention.....	18	Fluid Penetration	15
Ether	20	Inhalation	15
Fire Extinguisher.....	20	Pressurized Air and Water.....	14
Lines, Tubes, and Hoses	20	Static Electricity Hazard when Fueling with	
Fluid Recommendations	67	Ultra-low Sulfur Diesel Fuel	15
Fluid Recommendations.....	67	H	
Foreword	4	High Pressure Fuel Lines	21
California Proposition 65 Warning.....	4		
Literature Information	4		

Four Cylinder engine	22	O	
Three Cylinder Engine	23	Operation Section.....	42
Hoses and Clamps - Inspect/Replace.....	119	Ordering Replacement Parts.....	129
Replace the Hoses and the Clamps	120	Overhaul Considerations.....	120
I		Oil Consumption as an Overhaul	
Important Safety Information.....	2	Indicator	120
L		Overhaul Recommendation.....	121
Lifting and Storage	42	Overspeed.....	50
M		P	
Maintenance Interval Schedule.....	75	Plate Locations and Film Locations	41
Commissioning	76	Plate.....	41
Daily	75	Serial Number Plate.....	41
Every 1000 Service Hours.....	75	Product Description.....	38
Every 12 000 Service Hours or 6 Years.....	76	Aftermarket Products and Caterpillar	
Every 1500 Service Hours.....	75	Engines	40
Every 2000 Service Hours.....	75	Aftertreatment System.....	39
Every 250 Service Hours	75	Electronic Engine Features	40
Every 3000 Service Hours.....	75	Engine Diagnostics.....	40
Every 3000 Service Hours or 3 Years	76	Four Cylinder Engine C2.2	39
Every 4000 Service Hours.....	76	Service Life	40
Every 50 Service Hours or Weekly	75	Three Cylinder Engine C1.7	38
Every 500 Service Hours.....	75	Product Identification Information	41
Every 500 Service Hours or 1 Year	75	Product Information Section.....	27
Every 6000 Service Hours or 3 Years	76	Product Lifting	42
Every Year	75	Engine and Aftertreatment.....	42
Overhaul	76	Open Power Unit (OPU).....	42
When Required.....	75	Product Storage	43
Maintenance Log.....	131	R	
Maintenance Recommendations	72	Radiator - Clean	121
Maintenance Records	130	Radiator Mounts - Inspect.....	122
Maintenance Section.....	66	Reference Information.....	41
Model View Illustrations	27	Record for Reference	41
Four Cylinder Engine.....	32	Reference Information Section	127
Off Engine Components for Three and Four		Reference Materials	130
Cylinder Engines.....	35	Refill Capacities.....	66
Off Engine Components for Three and Four		Coolant Capacities	66
Cylinder OPU.....	38	Engine Oil Refill Capacities	66
Open Power Unit (OPU).....	36	S	
Three Cylinder Engine.....	28	Safety Messages.....	6
Model Views	27	(1) Universal Warning	6
Monitoring System.....	47	(2) Hand (High Pressure)	7
Programmable Options and Systems		(3) Ether Warning	8
Operation	47	Open Power Unit (OPU).....	8
Monitoring System (Engine Warning		Safety Section	6
Indicators).....	46	Self-Diagnostics	51
Mounting and Dismounting	21	Sensors and Electrical Components.....	47

Severe Service Application	74
Environmental Factors.....	74
Incorrect Maintenance Procedures	74
Incorrect Operating Procedures	74
Starting Motor - Inspect	122
Starting the Engine.....	53
Starting the Engine	53
Starting with Jump Start Cables (Do Not Use This Procedure in Hazardous Locations that have Explosive Atmospheres)	54
Stopping the Engine	60
System Pressure Release.....	72
Coolant System	72
Engine Oil	72
Fuel System.....	72

T

Table of Contents	3
Turbocharger - Inspect	123

W

Walk-Around Inspection	123
High-Pressure Fuel Lines.....	123
Inspect the Engine for Leaks and for Loose Connections	123
Warranty Information.....	126
Warranty Section	126
Water Pump - Inspect.....	124
Welding on Engines with Electronic Controls	72

Product and Dealer Information

Note: For product identification plate locations, see the section "Product Identification Information" in the Operation and Maintenance Manual.

Delivery Date: _____

Product Information

Model: _____

Product Identification Number: _____

Engine Serial Number: _____

Transmission Serial Number: _____

Generator Serial Number: _____

Attachment Serial Numbers: _____

Attachment Information: _____

Customer Equipment Number: _____

Dealer Equipment Number: _____

Dealer Information

Name: _____ Branch: _____

Address: _____

Dealer Contact

Phone Number

Hours

Sales: _____

Parts: _____

Service: _____

M0114093
©2024 Caterpillar
All Rights Reserved

CAT, CATERPILLAR, LET'S DO THE WORK, their respective logos, "Caterpillar Corporate Yellow", the "Power Edge" and Cat "Modern Hex" trade dress as well as corporate and product identity used herein, are trademarks of Caterpillar and may not be used without permission.

